

NO. SETS	DATE
RECORD PLANS	
CONSTRUCTION PLANS	

COUNTY OF	ITEM NO.	SHEET NO.
TRIGG	I-180.11	R1

Commonwealth of Kentucky DEPARTMENT OF HIGHWAYS

PLANS OF PROPOSED PROJECT

TRIGG CO. U.S. 68 / KY. 80



STA. 4225+38.33
END RIGHT OF WAY

STA. 4240+20.00
BEGIN TEMP TIE

STA. 4252+00.00
END PROJECT

STA. 4260+83.43
END TEMP TIE

THIS PROJECT IS A PARTIALLY
CONTROLLED ACCESS HIGHWAY.
ACCESS SHALL BE PROVIDED ONLY
WHERE SPECIFICALLY INDICATED
ON PLANS.

THIS PROJECT IS ON THE NH SYSTEM

RIGHT OF WAY PLANS

SHEET NO.	DESCRIPTION
R1	LAYOUT SHEET
R2	TYPICAL SECTIONS-SUMMARY OF QUANTITIES
R3-R47	PLAN AND PROFILE SHEETS
R48	RIGHT OF WAY SUMMARY SHEETS
R49-R51	RIGHT OF WAY STRIP MAP SHEETS
R52-R53	MAINTENANCE OF TRAFFIC
R54-R57	COORDINATE CONTROL SHEETS

SHEETS NOT INCLUDED IN TOTAL SHEETS
2a-2f, 6A

STANDARD DRAWINGS				
NUMBER				
RBI-001-09	RDB-106-04	RDI-020-08	RFW-005-06	TTC-145-01
RBI-002-06	RDB-110-07	RDI-021	RGS-001-06	TTC-146-01
RBR-001-11	RDB-155-01	RDI-025-04	RGS-002-05	TTC-150-01
RBR-005-10	RDB-160-01	RDI-026	RGX-001-05	TTC-155-01
RBR-010-05	RDD-040-04	RDI-035-01	RGX-002-08	TTC-160-01
RBR-015-04	RDH-020-03	RDI-045-01	RGX-005-05	TTD-110-01
RBR-016-04	RDH-030-03	RDX-001-05	RGX-200	TTS-100-01
RBR-025-03	RDH-110-02	RDX-002-03	RPM-110-05	TTS-105-01
RBR-035-08	RDH-210-03	RDX-060-03	TPM-100-01	TTS-110-01
RDB-001-11	RDH-220-02	RDX-065-03	TPM-105-01	TTS-115-01
RDB-003-07	RDH-310-04	RDX-210-02	TPM-115-01	
RDB-005-08	RDH-350-03	RDX-215	TPM-120-01	
RDB-007-02	RDI-001-08	RDX-220-04	TTC-100-01	
RDB-008-03	RDI-002-03	RDX-225	TTC-105-01	
RDB-100-04	RDI-003-03	RDX-230	TTC-115-01	
RDB-101-04	RDI-011-02	RFG-001-06	TTC-120-01	
RDB-105-05	RDI-016-02	RFW-001-04	TTC-135-01	

Sepius

EQUATION CHANGE:
STA. 5189+42.93 BACK =
STA. 4117+08.88 AHEAD

STA. 5160+43.45
BEGIN PROJECT

STA. 5170+71.04
BEGIN RIGHT OF WAY

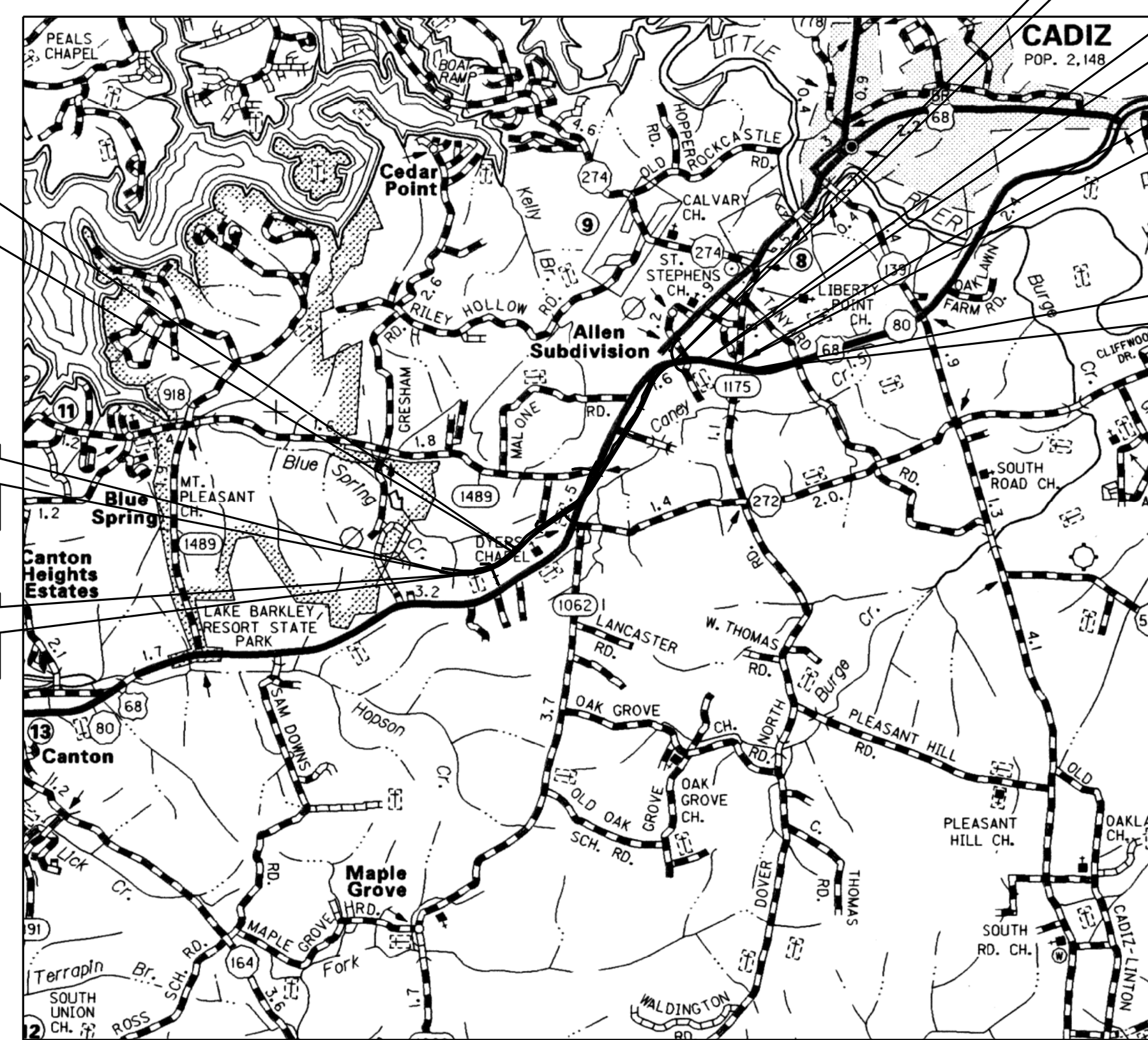

LAYOUT MAP

DESIGN CRITERIA	
CLASS OF HIGHWAY	RURAL ARTERIAL
TYPE OF TERRAIN	ROLLING
DESIGN SPEED	60 MPH
REQUIRED NPSD	570 FT.
REQUIRED PSD	2135 FT.
LEVEL OF SERVICE	
ADT PRESENT (2007)	5630
ADT FUTURE (2027)	9400
DHV	980
D %	
T %	16.6%
GEOGRAPHIC COORDINATES	
LATITUDE	36 DEGREES 49 MINUTES NORTH
LONGITUDE	87 DEGREES 52 MINUTES WEST
DESIGNED	
% RESTRICTED SD	
LEVEL OF SERVICE	
MAX. DISTANCE W/O PASSING	

LENGTH	LIN. FT.	MILES	ADDED	DEDUCTED	FOR EQUALITIES	NOT INCLUDED	RAILROAD CROSSINGS NO.	BRIDGES	LIN. FT.	MILES	ADDED	DEDUCTED	FOR EQUALITIES	NOT INCLUDED	RAILROAD CROSSINGS NO.	BRIDGES	LIN. FT.	MILES	ADDED	DEDUCTED	FOR EQUALITIES	NOT INCLUDED	RAILROAD CROSSINGS NO.	BRIDGES	LIN. FT.	MILES
16.391		3.104																								

USER: \$\$\$USER\$\$\$
DATE: \$\$\$DATE\$\$\$
FILE NAME: \$\$\$designsfiles\$specifications\$\$\$
E-SHEET NAME:

**Commonwealth of Kentucky
DEPARTMENT OF HIGHWAYS
COUNTY OF**

TRIGG

ITEM NO. I-180.11
PROJECT U.S. 68 / KY. 80
NUMBER:
LETTING DATE:

RECOMMENDED BY: _____ DATE: _____
PROJECT MANAGER

PLAN APPROVED BY: _____ DATE: _____
STATE HIGHWAY ENGINEER

EA Partners, PLLC

CIVIL ENGINEERS • LAND SURVEYORS • LANDSCAPE ARCHITECTS

311 WALL STREET
LEXINGTON, KENTUCKY 40513
PHONE (859) 256-9889
FACSIMILE (859) 256-9887

TYPICAL SECTIONS

U.S. 68 / KY. 80

PREPARED BY _____ DATE _____
 CHECKED BY _____ DATE _____
 APPROVED BY _____ DATE _____

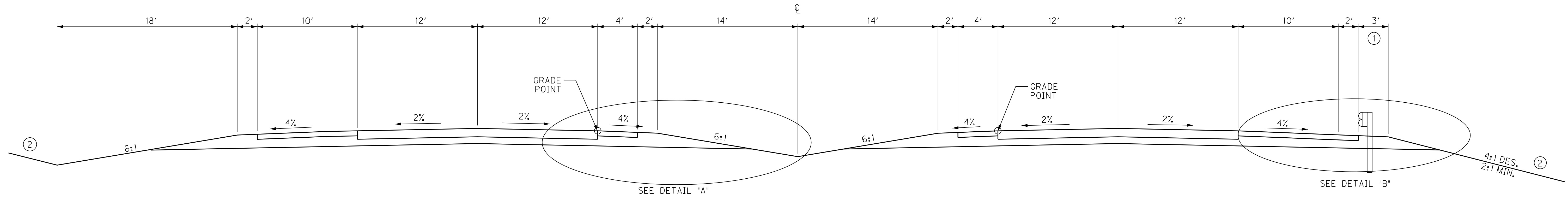

NORMAL SECTION

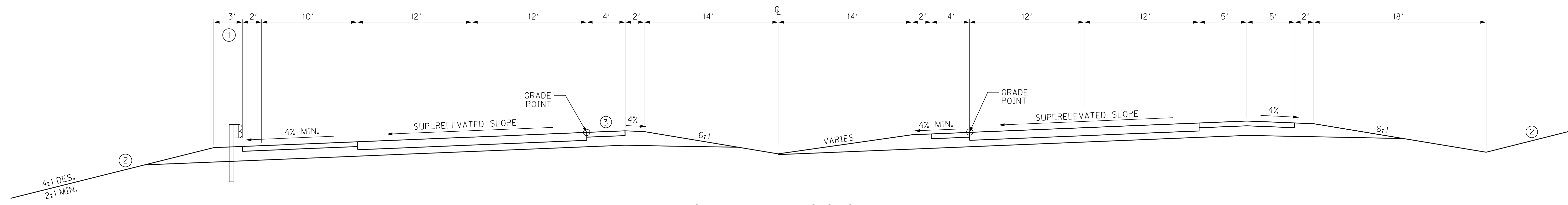

SUPERELEVATED SECTION

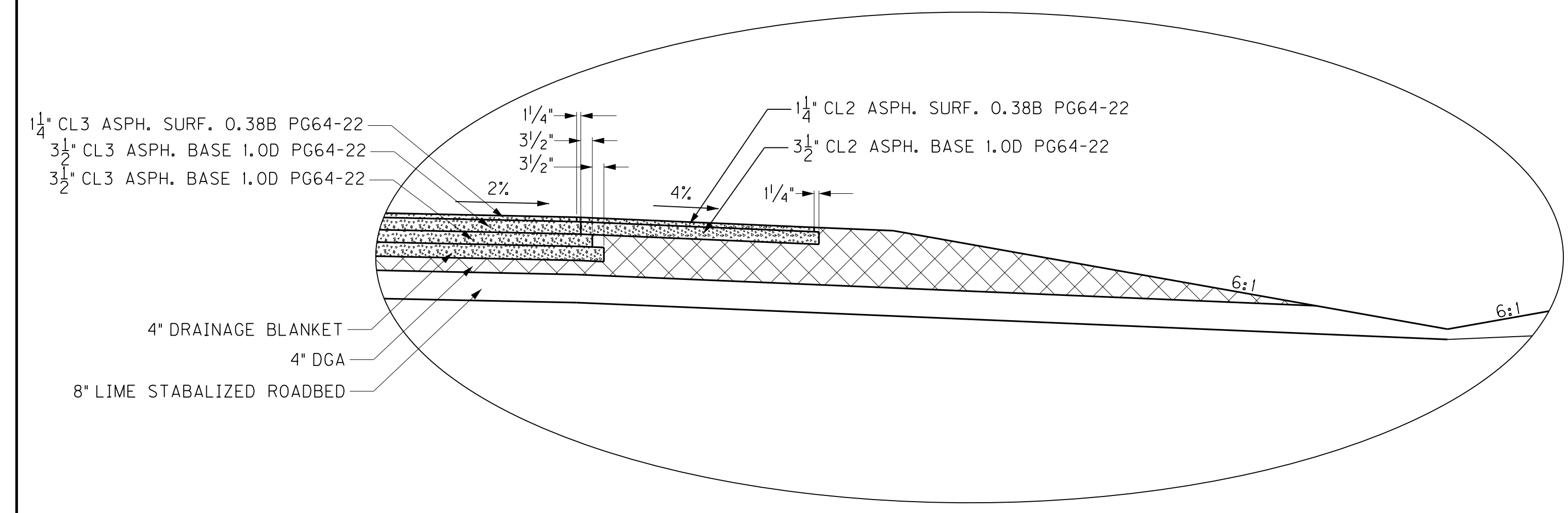

DETAIL "A"

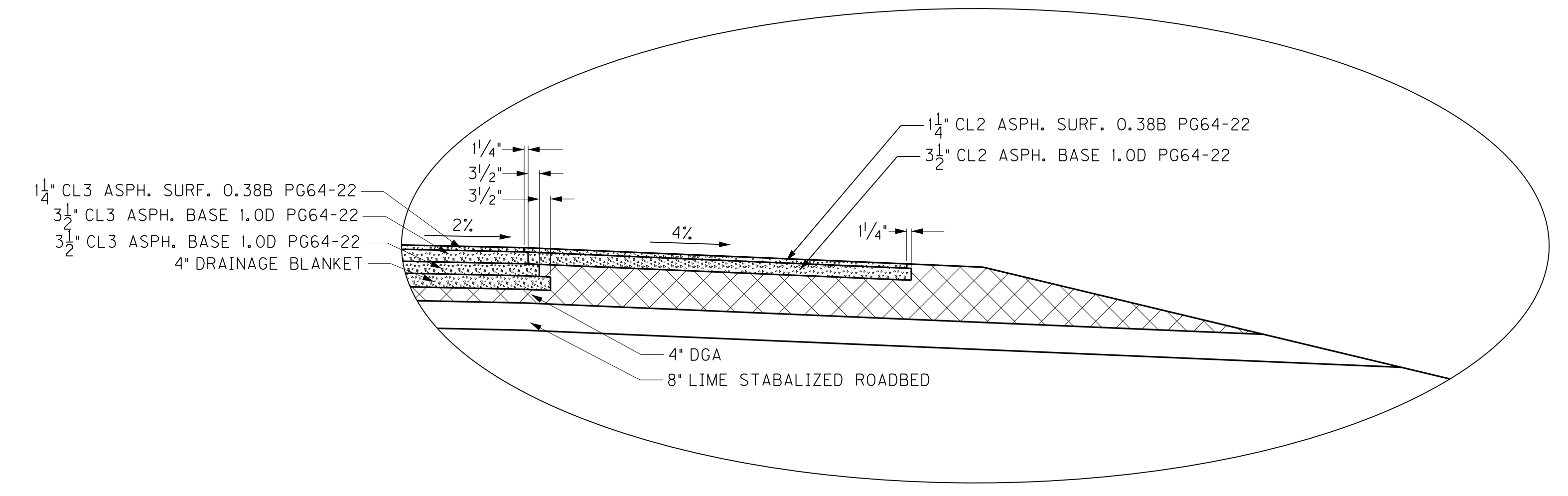

DETAIL "B"

- ① SHOULDER SHALL BE WIDENED 3.0' WHERE GUARDRAIL IS TO BE INSTALLED.
- ② SEE CROSS-SECTIONS FOR SLOPES OUTSIDE THE LIMITS OF THE SHOULDER.

NOT TO SCALE

TYPICAL SECTIONS

USER: \$\$\$USER\$\$\$
 DATE: \$\$\$DATE\$\$\$
 FILE NAME: \$\$\$designsfiles\$\$\$specifications\$\$\$
 E-SHEET NAME:

TYPICAL SECTIONS

U.S.68KY.80 WITH LEFT TURN LANE

PREPARED BY _____ DATE _____
 CHECKED BY _____ DATE _____
 APPROVED BY _____ DATE _____

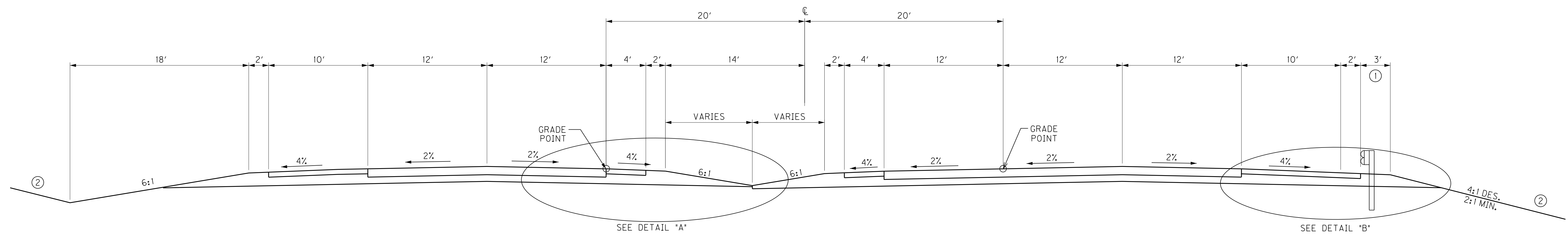

NORMAL SECTION

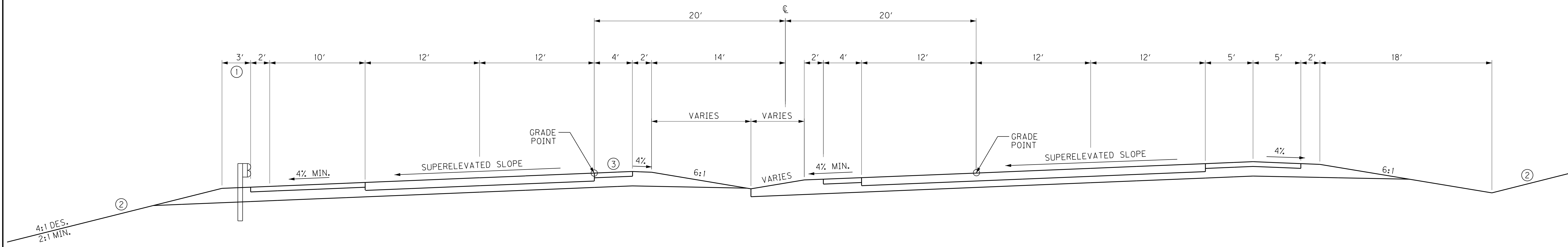

SUPERELEVATED SECTION

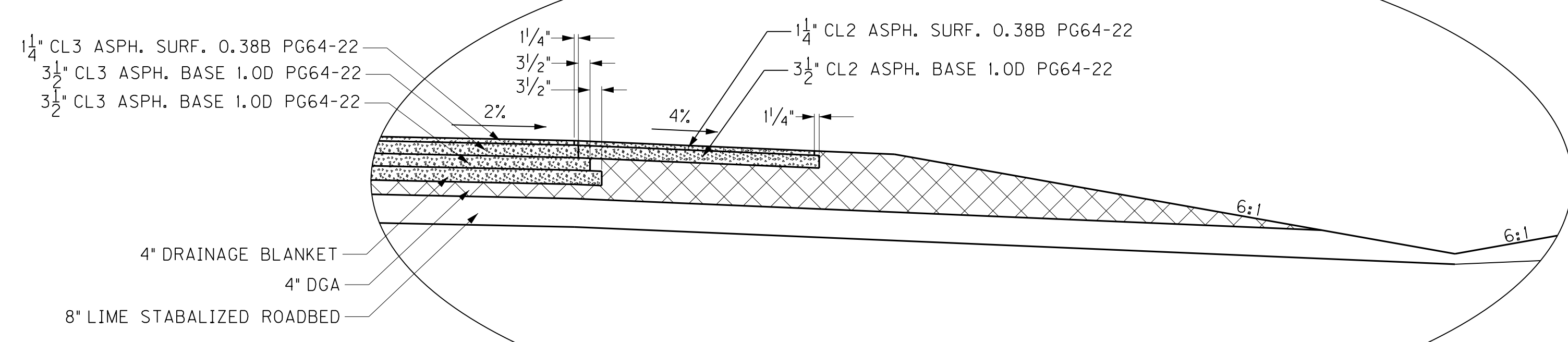

DETAIL "A"

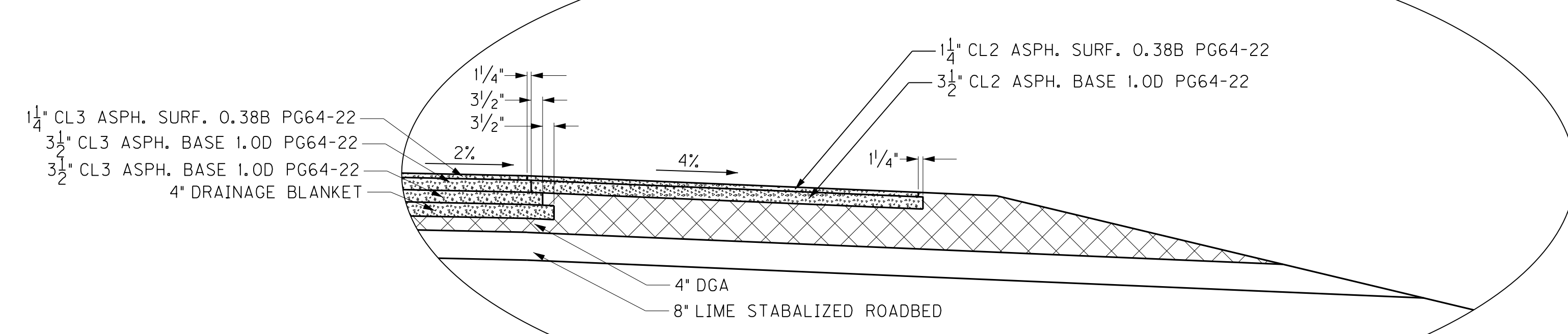

DETAIL "B"

- ① SHOULDER SHALL BE WIDENED 3.0' WHERE GUARDRAIL IS TO BE INSTALLED.
- ② SEE CROSS-SECTIONS FOR SLOPES OUTSIDE THE LIMITS OF THE SHOULDER.

NOT TO SCALE

TYPICAL SECTIONS

USER: \$\$\$USER\$\$\$
 DATE: \$\$\$DATE\$\$\$
 FILE NAME: \$\$\$designsfiles\$\$\$specifications\$\$\$
 E-SHEET NAME:

TYPICAL SECTIONS

US 68X CANTON ROAD

PREPARED BY _____ DATE _____
 CHECKED BY _____ DATE _____
 APPROVED BY _____ DATE _____

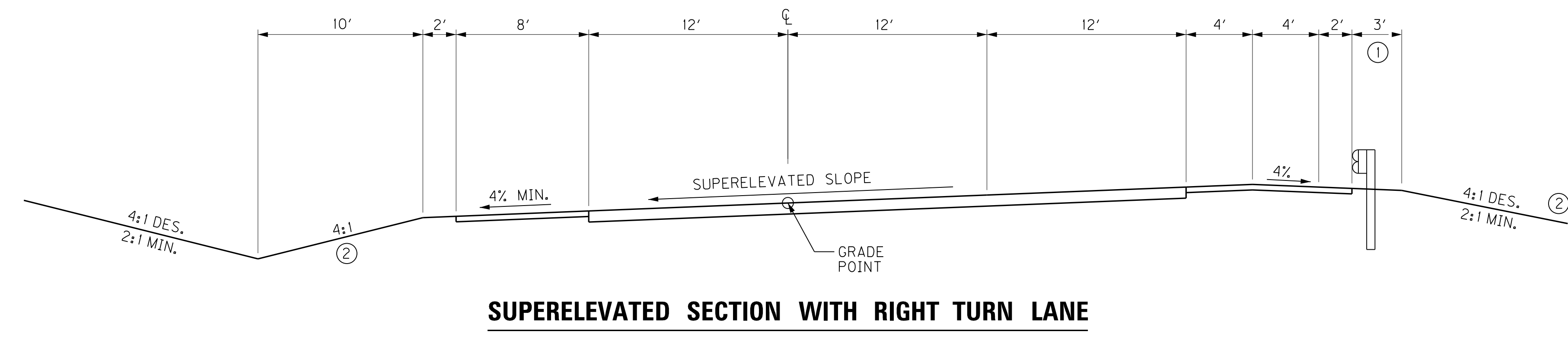
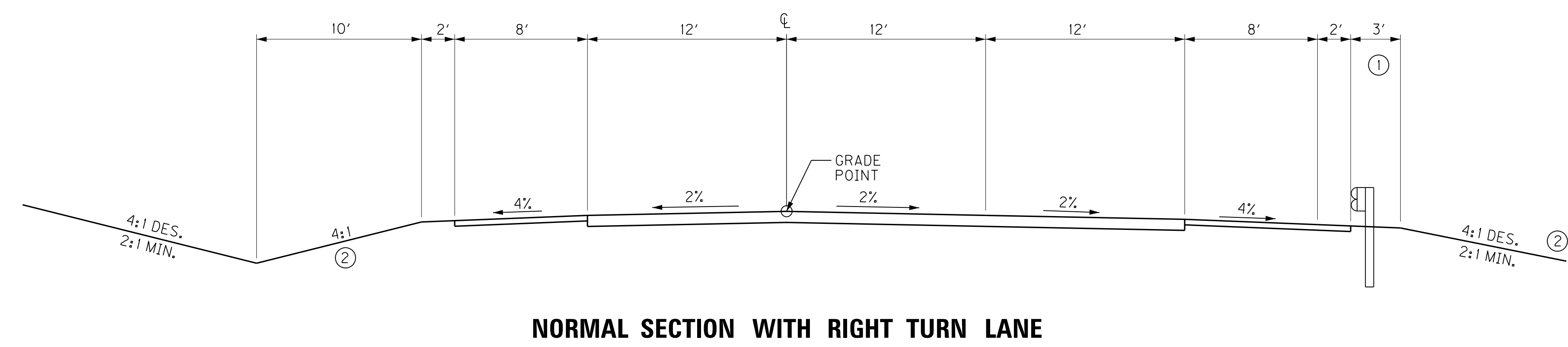
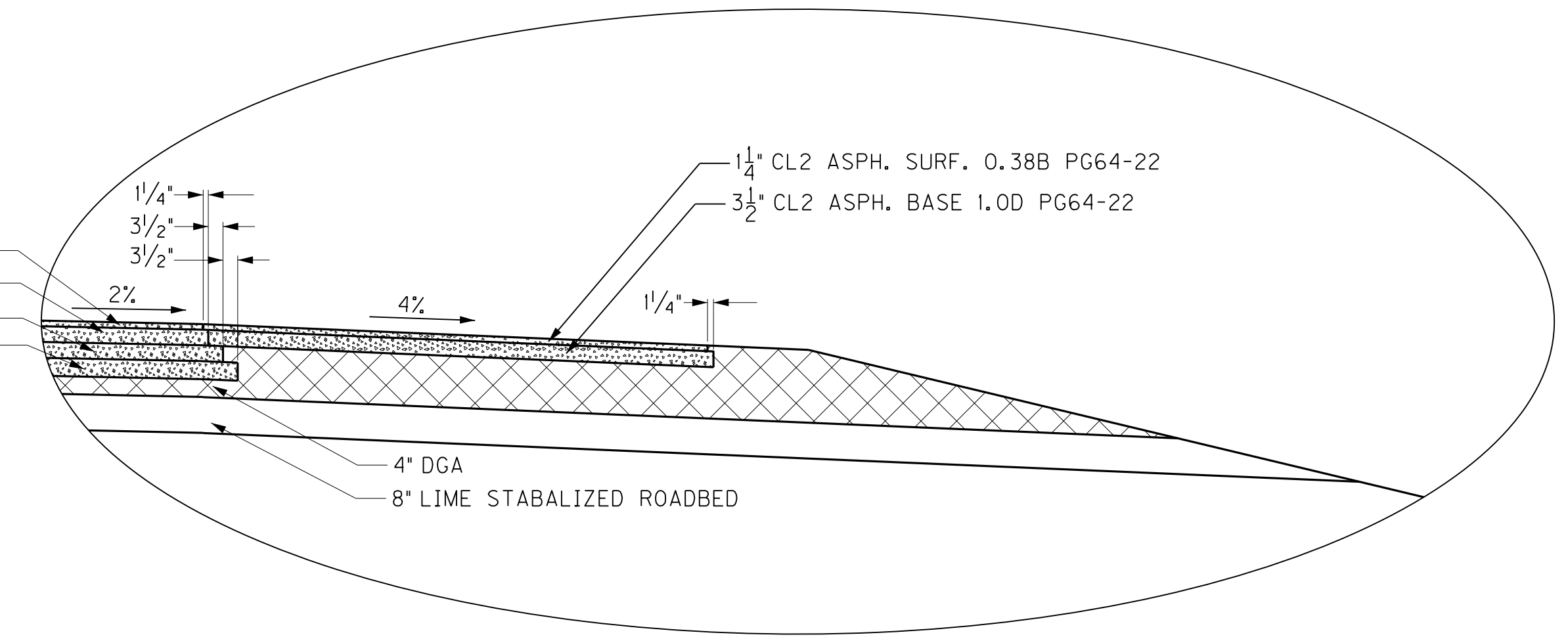
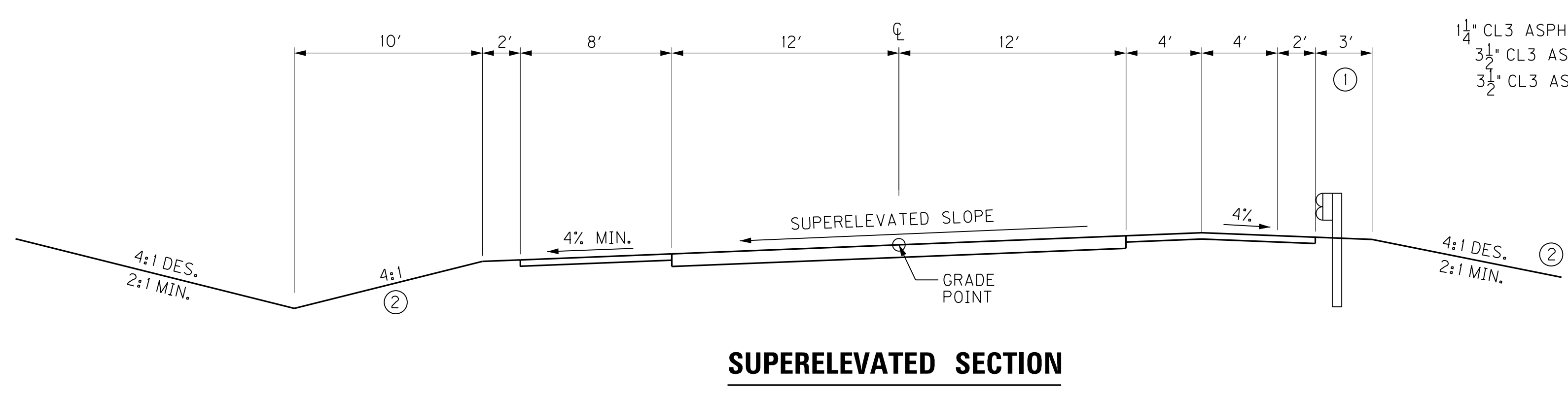
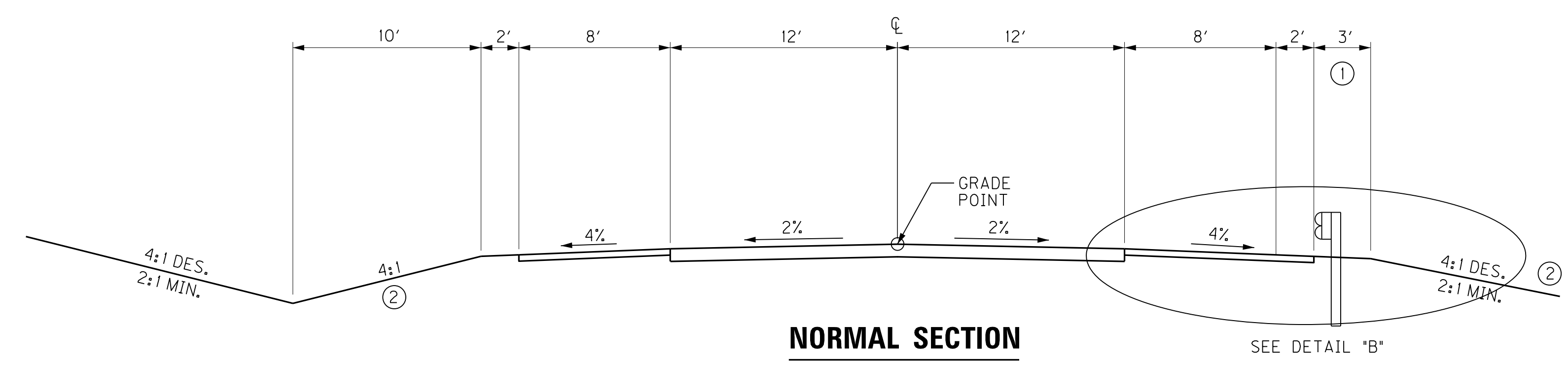

- ① SHOULDER SHALL BE WIDENED 3.0' WHERE GUARDRAIL IS TO BE INSTALLED.
- ② SEE CROSS-SECTIONS FOR SLOPES OUTSIDE THE LIMITS OF THE SHOULDER.

USER: \$\$\$USER\$\$\$
 DATE: \$\$\$DATE\$\$\$
 FILE NAME: \$\$\$designsfiles\$specifications\$\$\$
 E-SHEET NAME:

NOT TO SCALE

TYPICAL SECTIONS

COUNTY OF	ITEM NO.	SHEET NO.
TRIGG	1-180.11	R2c

TYPICAL SECTIONS

APPROACH ROADS

AVERITT LUMBER ROAD **KY 1489**
HERITAGE ROAD **U.S. 68 AT KY 1489**
KY 272 **MACK CUNNINGHAM ROAD**
U.S. 68 AT KY 272 **U.S. 68 CONNECTOR**
KY 1062 **CLARKSDALE ROAD**
WARRENTON SCHOOL ROAD **BRAYBOY HANDLEY LANE**

EDGE KEY DETAIL

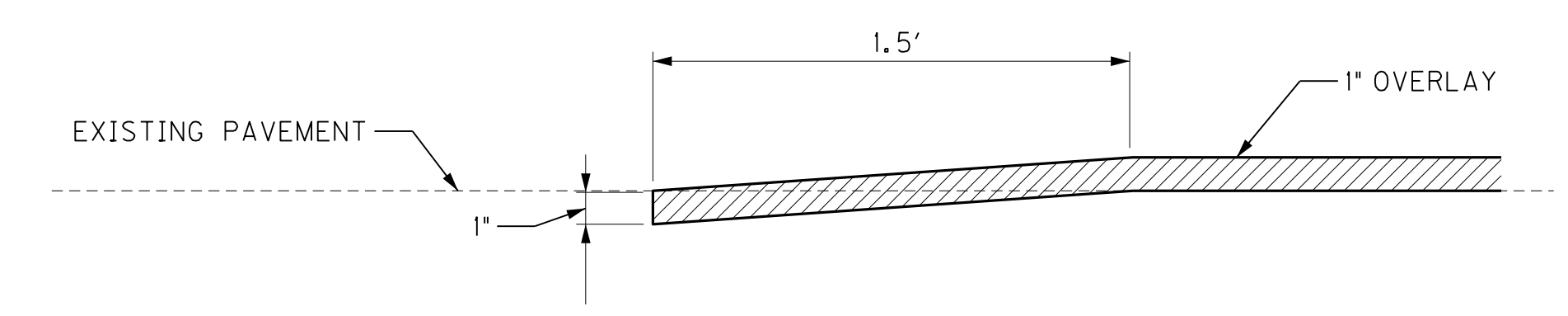

WORK UNDER THIS ITEM SHALL INCLUDE CUTTING OUT THE EXISTING BITUMINOUS SURFACE TO A MINIMUM DEPTH AND WIDTH AS SHOWN, SO THE NEW SURFACE MAY HEEL INTO THE EXISTING SURFACE. THE CONTRACT UNIT PRICE BID PER FOOT FOR "EDGE KEY" SHALL INCLUDE ALL NECESSARY MATERIALS, LABOR, EQUIPMENT, ETC. TO PERFORM THE WORK AND DISPOSE OF THE BITUMINOUS MATERIAL REMOVED.

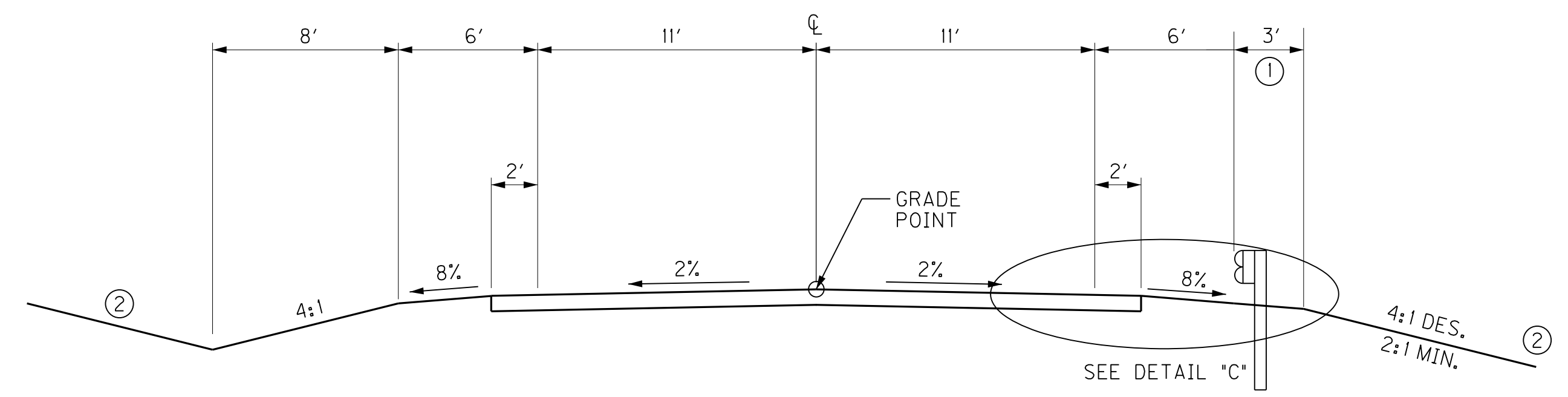

NORMAL SECTION

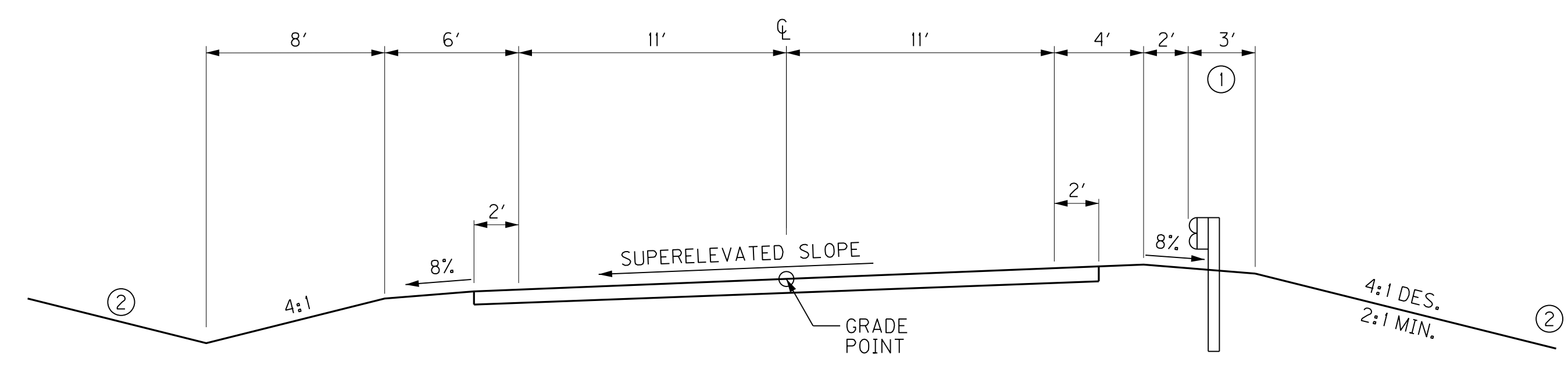

SUPERELEVATED SECTION

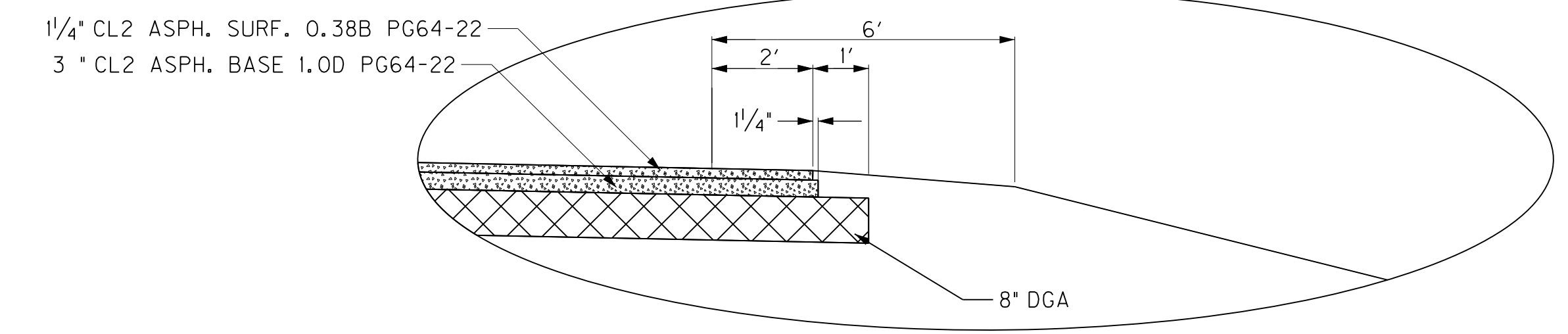

DETAIL "C"

- ① SHOULDER SHALL BE WIDENED 3.0' WHERE GUARDRAIL IS TO BE INSTALLED.
- ② SEE CROSS-SECTIONS FOR SLOPES OUTSIDE THE LIMITS OF THE SHOULDER.

NOT TO SCALE

TYPICAL SECTIONS

PREPARED BY _____ DATE _____
 CHECKED BY _____ DATE _____
 APPROVED BY _____ DATE _____

USER: \$\$\$USER\$\$\$
 DATE: \$\$\$DATE\$\$\$
 FILE NAME: \$\$\$designsfiles\$\$\$specifications\$\$\$
 E-SHEET NAME:

TYPICAL SECTIONS

COUNTY OF	ITEM NO.	SHEET NO.
TRIGG	1-180.11	R2d

PREPARED BY _____ DATE _____
 CHECKED BY _____ DATE _____
 APPROVED BY _____ DATE _____

FRONTAGE ROADS

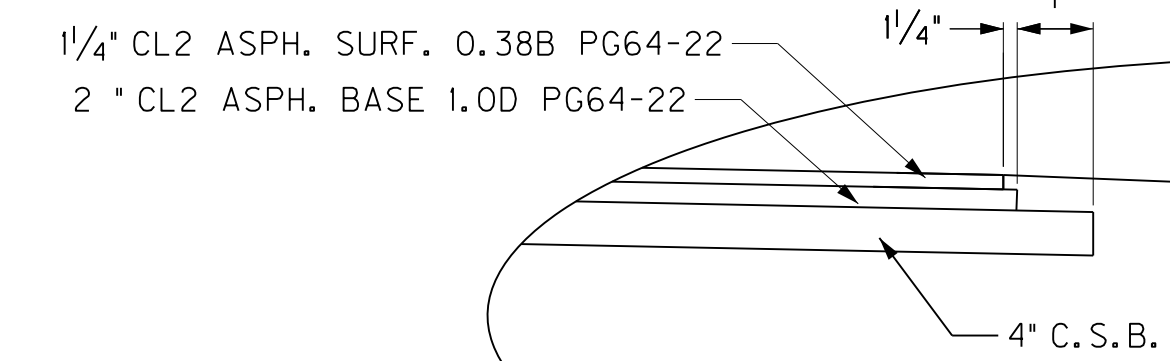
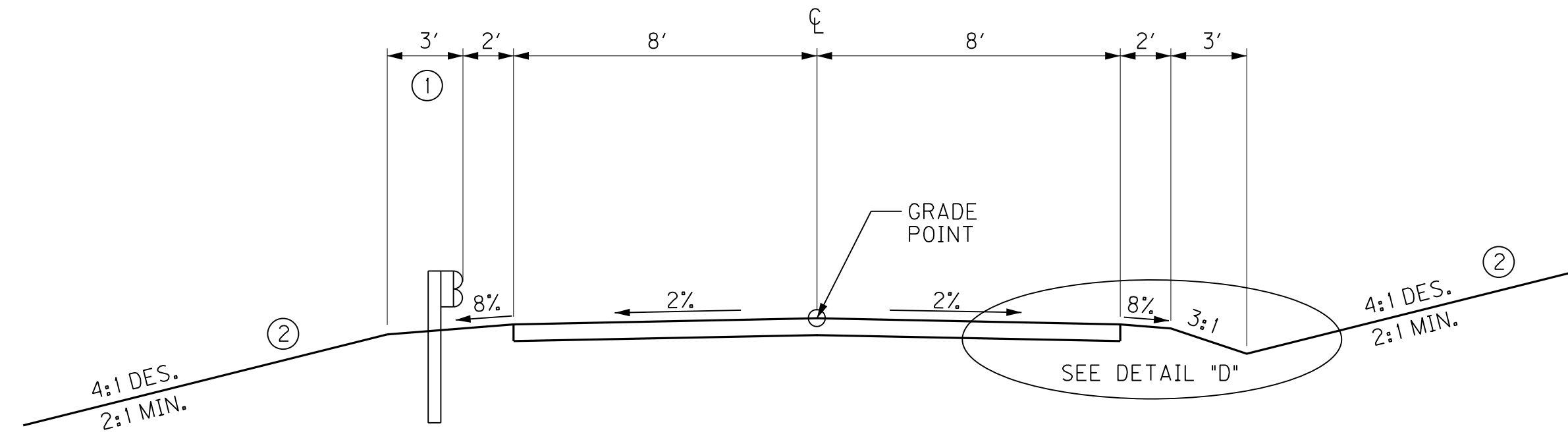

DETAIL "D"

ENTRANCES

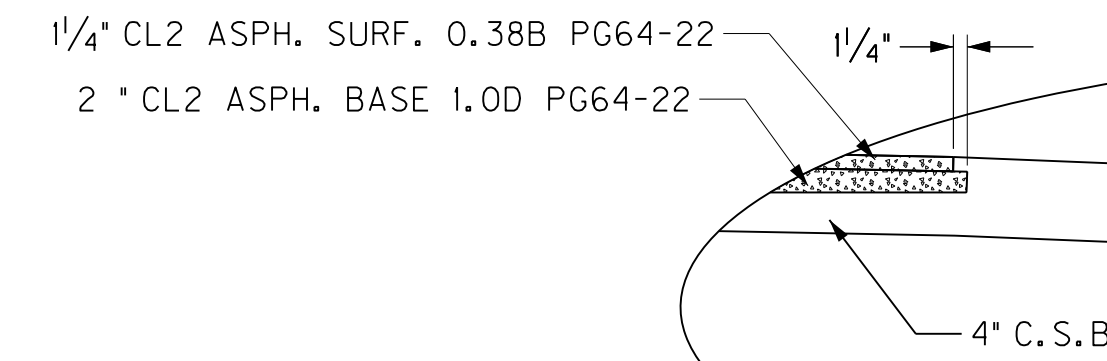
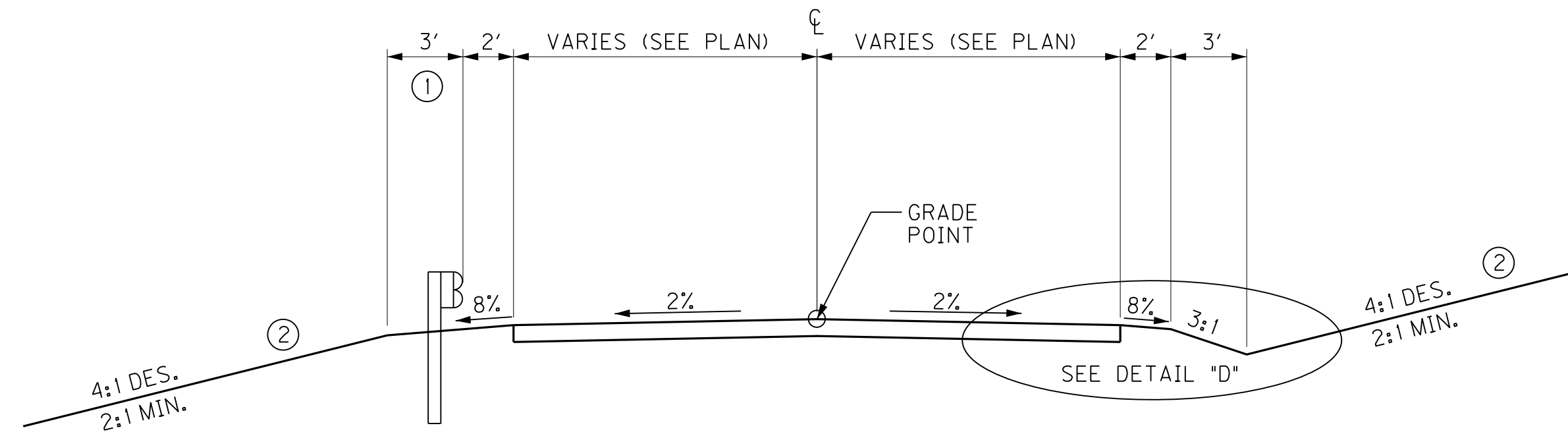

DETAIL "E"

SHARED USE PATH

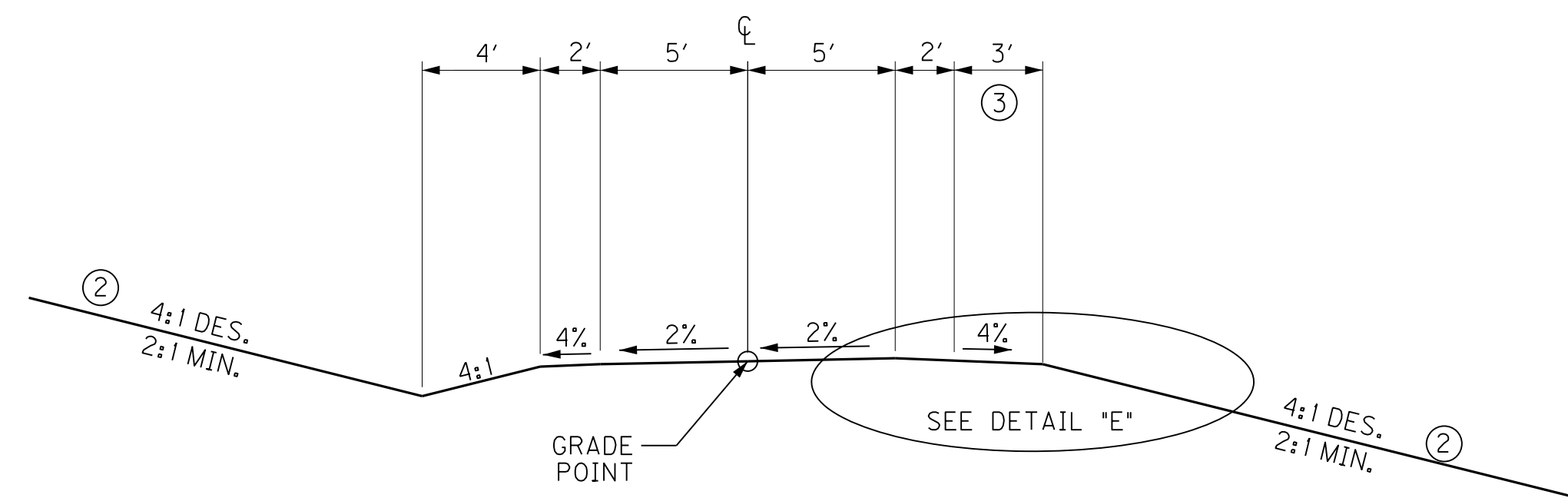

- ① SHOULDER SHALL BE WIDENED 3.0' WHERE GUARDRAIL IS TO BE INSTALLED.
- ② SEE CROSS-SECTIONS FOR SLOPES OUTSIDE THE LIMITS OF THE SHOULDER.
- ③ SHOULDER SHALL BE WIDENED 3' WHEN SIDESLOPE EXCEEDS 3:1.

USER: \$\$\$USER\$\$\$
 DATE: \$\$\$DATE\$\$\$
 FILE NAME: \$\$\$designsfiles\$specifications\$\$\$
 E-SHEET NAME:

NOT TO SCALE

TYPICAL SECTIONS

TYPICAL SECTIONS

COUNTY OF	ITEM NO.	SHEET NO.
TRIGG	1-180.11	R2e

DIVERSIONS

PREPARED BY _____ DATE _____
 CHECKED BY _____ DATE _____
 APPROVED BY _____ DATE _____

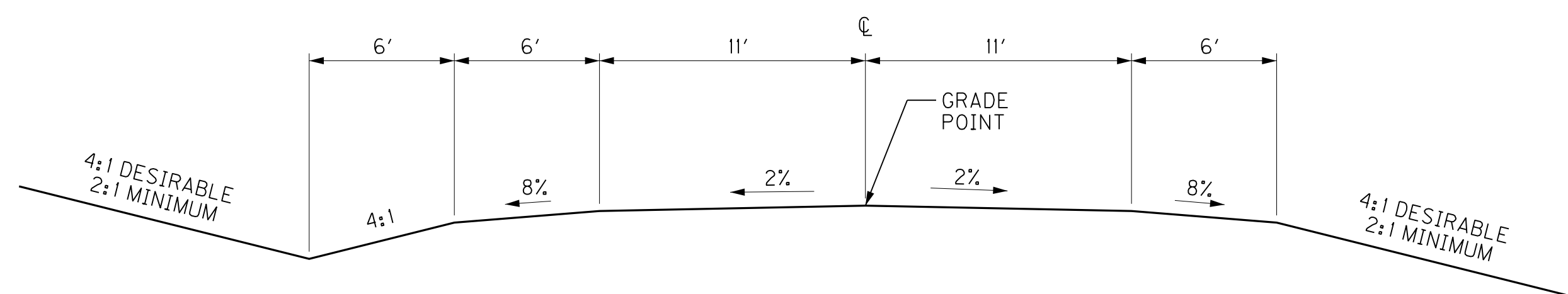

DIVERSION 1 NORMAL SECTION

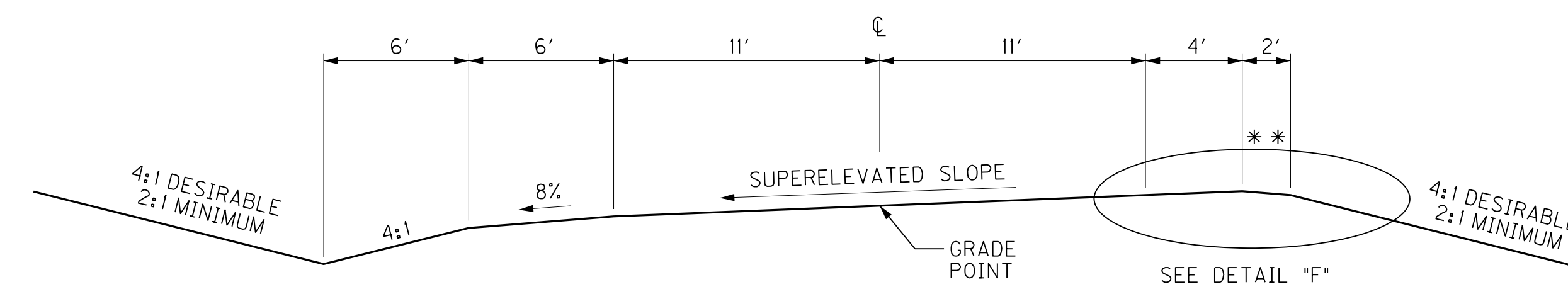

DIVERSION 1 SUPERELEVATED SECTION

** - 12% MAXIMUM BREAKOVER

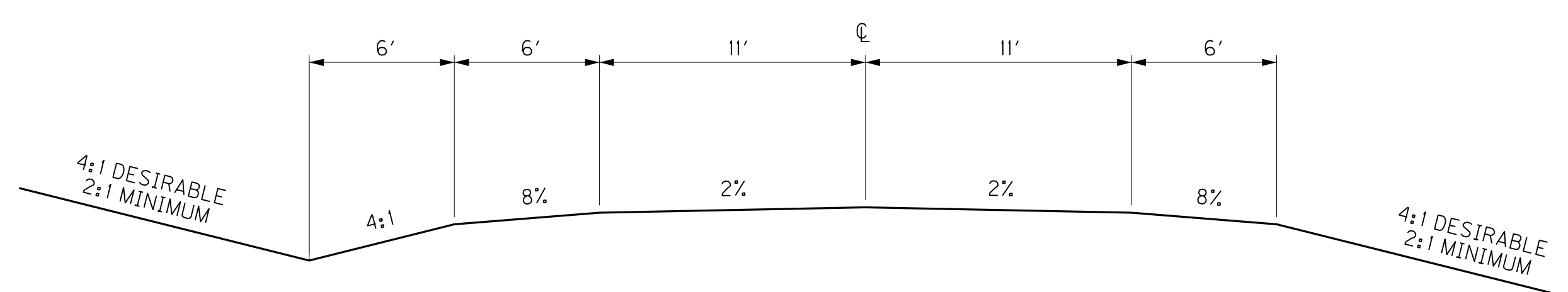

DIVERSION 2 NORMAL SECTION

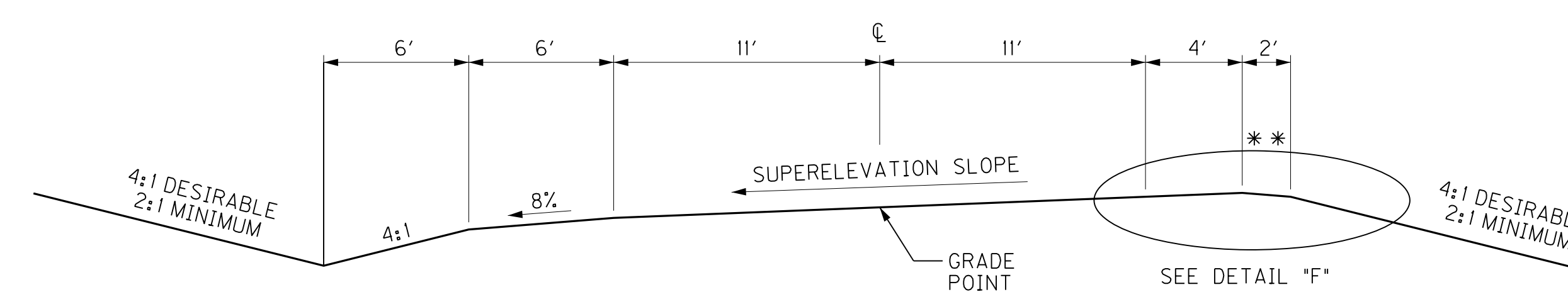

DIVERSION 2 SUPERELEVATED SECTION

** - 12% MAXIMUM BREAKOVER

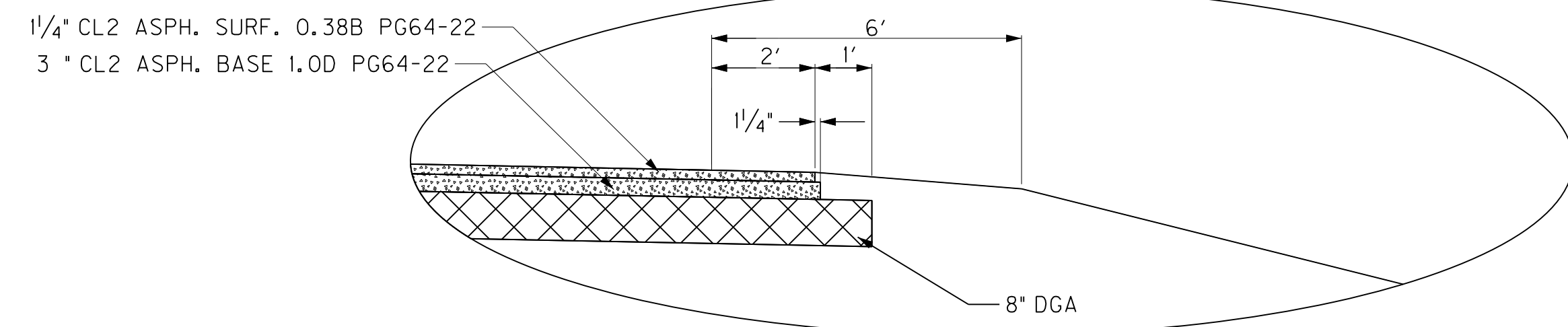

DETAIL "F"

USER: \$\$\$USER\$\$\$
 DATE: \$\$\$DATE\$\$\$
 FILE NAME: \$\$\$designsfiles\$\$\$specifications\$\$\$
 E-SHEET NAME:

NOT TO SCALE

MAINTENANCE OF TRAFFIC
 TYPICAL SECTIONS

TYPICAL SECTIONS

US-68 TEMPORARY TIE

PREPARED BY _____ DATE _____
 CHECKED BY _____ DATE _____
 APPROVED BY _____ DATE _____

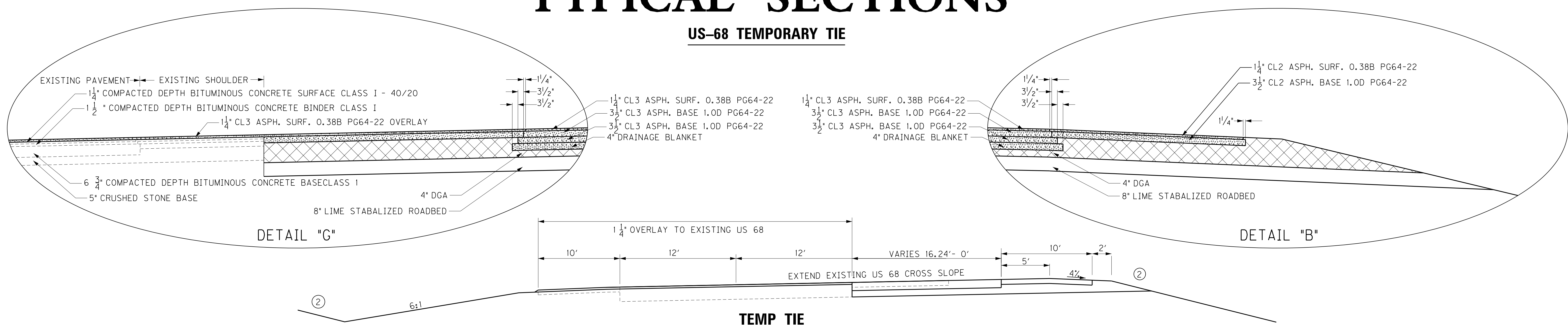

TEMP TIE
STA. STA.4254 + 70 TO 4260 + 83.43

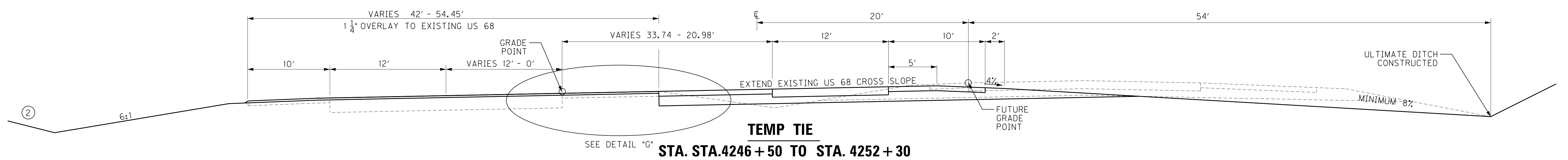

TEMP TIE
STA. STA.4246 + 50 TO STA. 4252 + 30

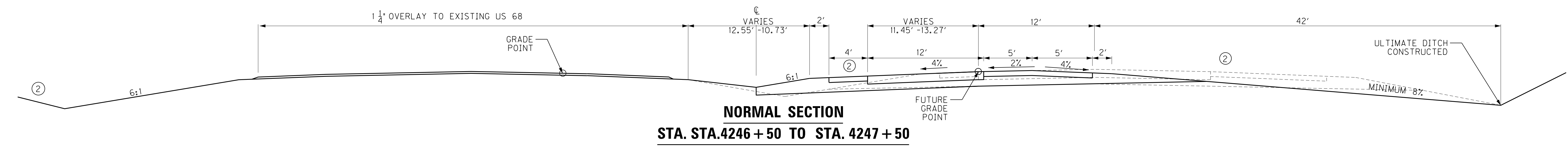

NORMAL SECTION
STA. STA.4246 + 50 TO STA. 4247 + 50

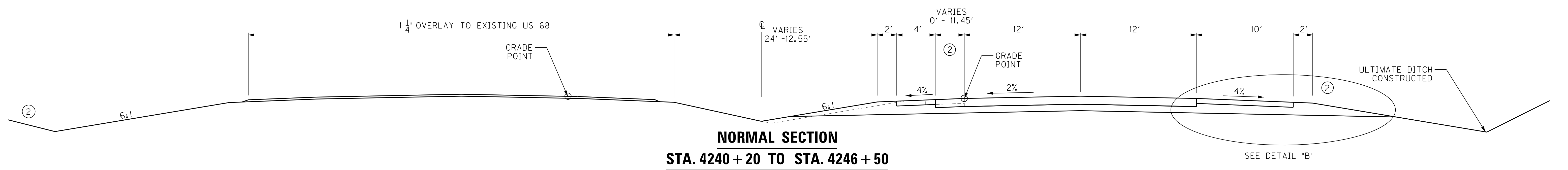

NORMAL SECTION
STA. 4240 + 20 TO STA. 4246 + 50

- ① SHOULDER SHALL BE WIDENED 3.0' WHERE GUARDRAIL IS TO BE INSTALLED.
- ② SEE CROSS-SECTIONS FOR SLOPES OUTSIDE THE LIMITS OF THE SHOULDER. NOT TO SCALE

USER: \$\$\$USER\$\$\$
 DATE: \$\$\$DATE\$\$\$
 FILE NAME: \$\$\$designsfiles\$\$\$
 E-SHEET NAME:

CONVENTIONAL SIGNS

- SURVEY LINE
- GRADE LINE
- GROUND LINE
- COUNTY LINE
- CORPORATE LIMITS
- EXIST. PROPERTY LINE
- EXIST. RIGHT OF WAY & PROPERTY LINE
- PROPOSED RIGHT OF WAY
- RIGHT OF WAY MONUMENT
- BENCH MARK
- EXISTING R/W MARKER
- RIGHT OF WAY MONUMENT EXISTING/PROPOSED
- UTILITY TEST HOLE
- EXISTING ROAD
- RAILROAD
- FENCE (CONTROLLED ACCESS)
- FENCE (EXCEPT STONE AND HEDGE)
- TREE LINE
- TREES
- PIPE CULVERT
- CULVERT
- BRIDGE
- BUILDINGS
- GUARDRAIL
- LIGHTING POLE
- POWER POLE
- JOINT POWER & TELEPHONE POLE
- TELEPHONE & TELEGRAPH POLE
- ANCHOR, POWER OR TELEPHONE
- STUB POWER
- STUB TELEPHONE
- WATER MAIN
- GAS MAIN
- TELEPHONE DUCT
- ELECTRIC DUCT
- DIRECT BURIAL TV CABLE
- SANITARY SEWER (WITH MANHOLE)
- STORM SEWER (WITH MANHOLE)
- DIRECT BURIAL ELECTRIC CABLE
- DIRECT BURIAL TELEPHONE CABLE
- OVERHEAD WIRE
- TRAFFIC LIGHTS
- ELECTRIC MANHOLE
- TELEPHONE MANHOLE
- STONE FENCE
- HEDGE FENCE
- SWAMP OR MARSH
- SPRINGS
- SINKHOLE
- QUARRY SITE
- BLUE LINE STREAM
- INTERMITTENT STREAM OR DITCH
- LAKES OR PONDS
- REGULATED FLOODWAY
- NORTH POINT

BEFORE YOU DIG

CALL 1-800-752-6007 TOLL FREE A MINIMUM OF TWO AND NO MORE THAN TEN BUSINESS DAYS PRIOR TO EXCAVATION FOR INFORMATION ON THE LOCATION OF EXISTING UNDERGROUND UTILITIES WHICH SUBSCRIBE TO THE BEFORE-U-DIG (BUD) SERVICE. COORDINATE EXCAVATION WITH ALL UTILITY OWNERS, INCLUDING THOSE WHO DO NOT SUBSCRIBE TO BUD.

DITCH CONSTRUCTION SUP. ☉					
STA. TO STA.	SIZE/TYPE	CHANNEL LINING			
		TYPE	DEPTH	QUANTITY	T
5160+43.45 TO 5161+50	2' F.B. SURF.	CL. II	1'	45 T	15"
5161+50	OUTLET	CL. II	1'	12 T	15"
5161+50 TO 5163+00	2' F.B. SURF.	CL. II	1'	67 T	15"

DITCH CONSTRUCTION LT. ☉					
STA. TO STA.	SIZE/TYPE	CHANNEL LINING			
		TYPE	DEPTH	QUANTITY	T
5160+43.45 TO 5161+00	NORM.	ECB	1'	46 S.Y.	-
5161+00 TO 5161+50	SPEC. "V"	ECB	1'	46 S.Y.	-
5161+50 TO 5163+00	SPEC. "V"	ECB	1'	137 S.Y.	-

LT STA. 5160+43.45 TO STA. 5163+00
CONST. 255 LF OF WOVEN WIRE
FENCE TYPE I

PI STA 5176+30.68
 $\Delta = 53^\circ 08' 50''$ LT
 $T_s = 1735.826'$
 $L_s = 184.00'$
 $L_c = 2864.07'$
 $\theta_s = 1^\circ 36' 00''$ LT
 $LT = 122.67'$
 $ST = 61.34'$
 $R = 3286.00'$
 $E = 388.61'$
 $e = 4.6\%$
 Runoff = 184'
 Runout = 80'

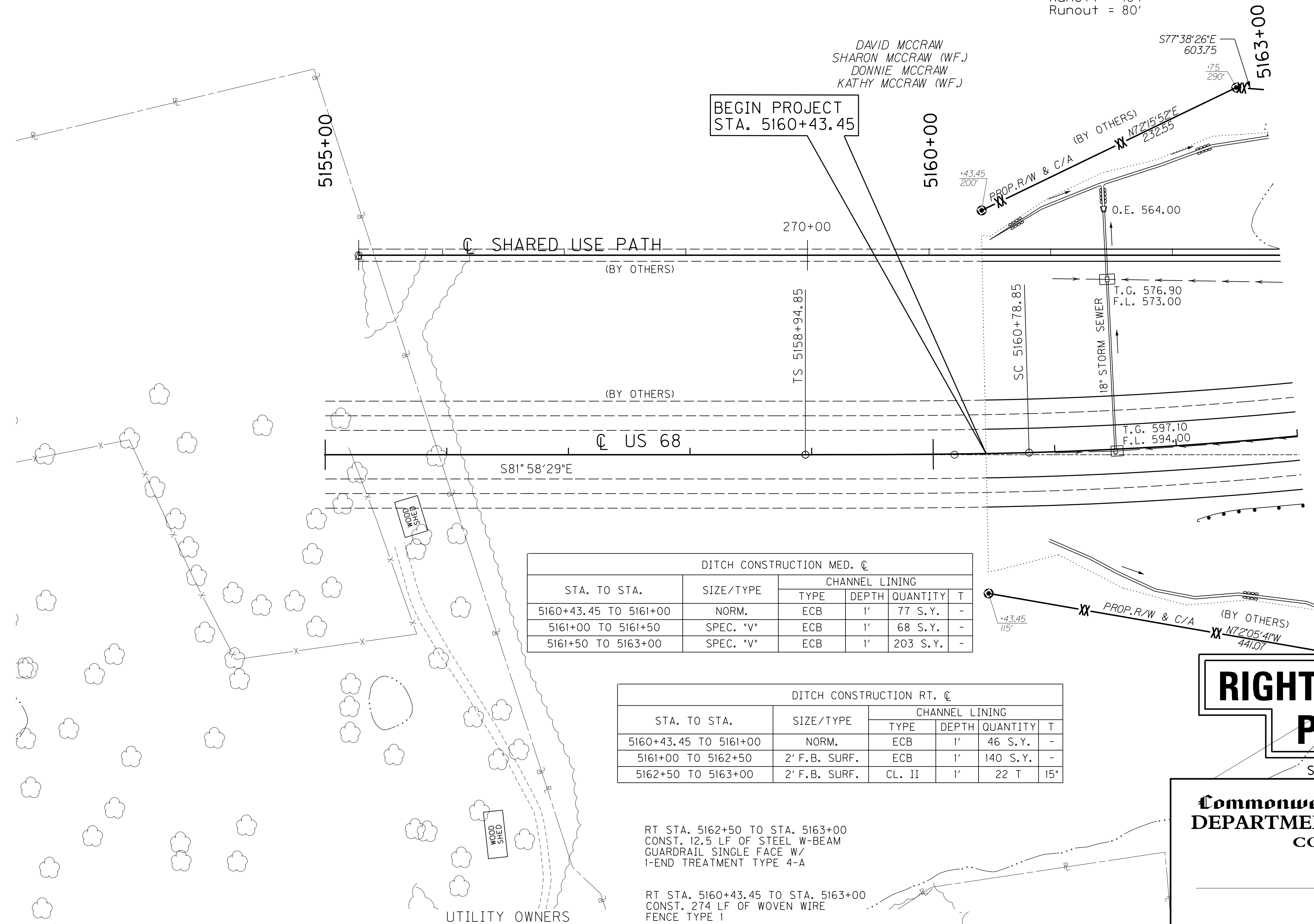
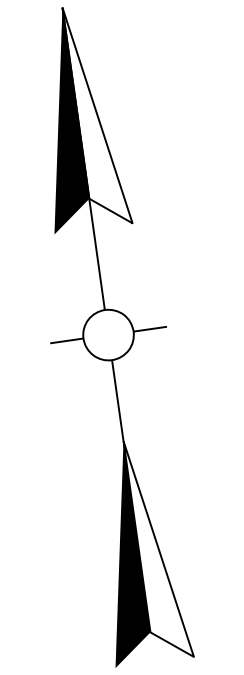

DAVID MCCRAW
 SHARON MCCRAW (WF.)
 DONNIE MCCRAW
 KATHY MCCRAW (WF.)

BEGIN PROJECT
 STA. 5160+43.45

DITCH CONSTRUCTION MED. ☉					
STA. TO STA.	SIZE/TYPE	CHANNEL LINING			
		TYPE	DEPTH	QUANTITY	T
5160+43.45 TO 5161+00	NORM.	ECB	1'	77 S.Y.	-
5161+00 TO 5161+50	SPEC. "V"	ECB	1'	68 S.Y.	-
5161+50 TO 5163+00	SPEC. "V"	ECB	1'	203 S.Y.	-

DITCH CONSTRUCTION RT. ☉					
STA. TO STA.	SIZE/TYPE	CHANNEL LINING			
		TYPE	DEPTH	QUANTITY	T
5160+43.45 TO 5161+00	NORM.	ECB	1'	46 S.Y.	-
5161+00 TO 5162+50	2' F.B. SURF.	ECB	1'	140 S.Y.	-
5162+50 TO 5163+00	2' F.B. SURF.	CL. II	1'	22 T	15"

RT STA. 5162+50 TO STA. 5163+00
 CONST. 12.5 LF OF STEEL W-BEAM
 GUARDRAIL SINGLE FACE W/
 1-END TREATMENT TYPE 4-A

RT STA. 5160+43.45 TO STA. 5163+00
 CONST. 274 LF OF WOVEN WIRE
 FENCE TYPE I

RIGHT OF WAY PLANS

SCALE: 1" = 50'

Commonwealth of Kentucky
DEPARTMENT OF HIGHWAYS
 COUNTY OF
TRIGG

PROJECT _____
 NUMBERS: _____

STA. 5160+43.45 TO STA. 5163+00

- PENNYRILE R.E.C.C.
 P.O. BOX 2900
 HOPKINSVILLE, KENTUCKY 42241
 (270) 886-2555
 GARY BREADEN, ENGINEER
- MEDIACOM SOUTHEAST LLC
 90 MAIN STREET
 BENTON, KENTUCKY 42025
 (270) 527-9939
 ALBERT GABORIAULT, CHIEF ENGINEER
- A.T. & T KENTUCKY
 801 RICHARD STREET
 HOPKINSVILLE, KENTUCKY 42240
 (270) 889-9782
 MICHAEL FORREST, ENGINEER
- BARKLEY LAKE WATER DISTRICT
 P.O. BOX 308
 CADIZ, KENTUCKY 42211
 (270) 924-5616
 TERRY GOINS, SUPERINTENDENT

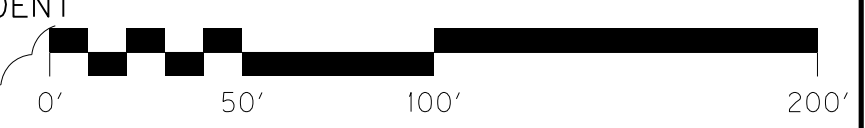

USER: \$\$\$USER\$\$\$
 DATE: \$\$\$DATE\$\$\$
 FILE NAME: \$\$\$designsfiles\$\$\$specifications\$\$\$
 E-SHEET NAME:

USER: \$\$\$USER\$\$\$

DATE: \$\$\$DATE\$\$\$

FILE NAME: \$\$\$designsfilespecification\$\$\$

E-SHEET NAME:

PREPARED BY _____ DATE _____
 CHECKED BY _____ DATE _____
 APPROVED BY _____ DATE _____

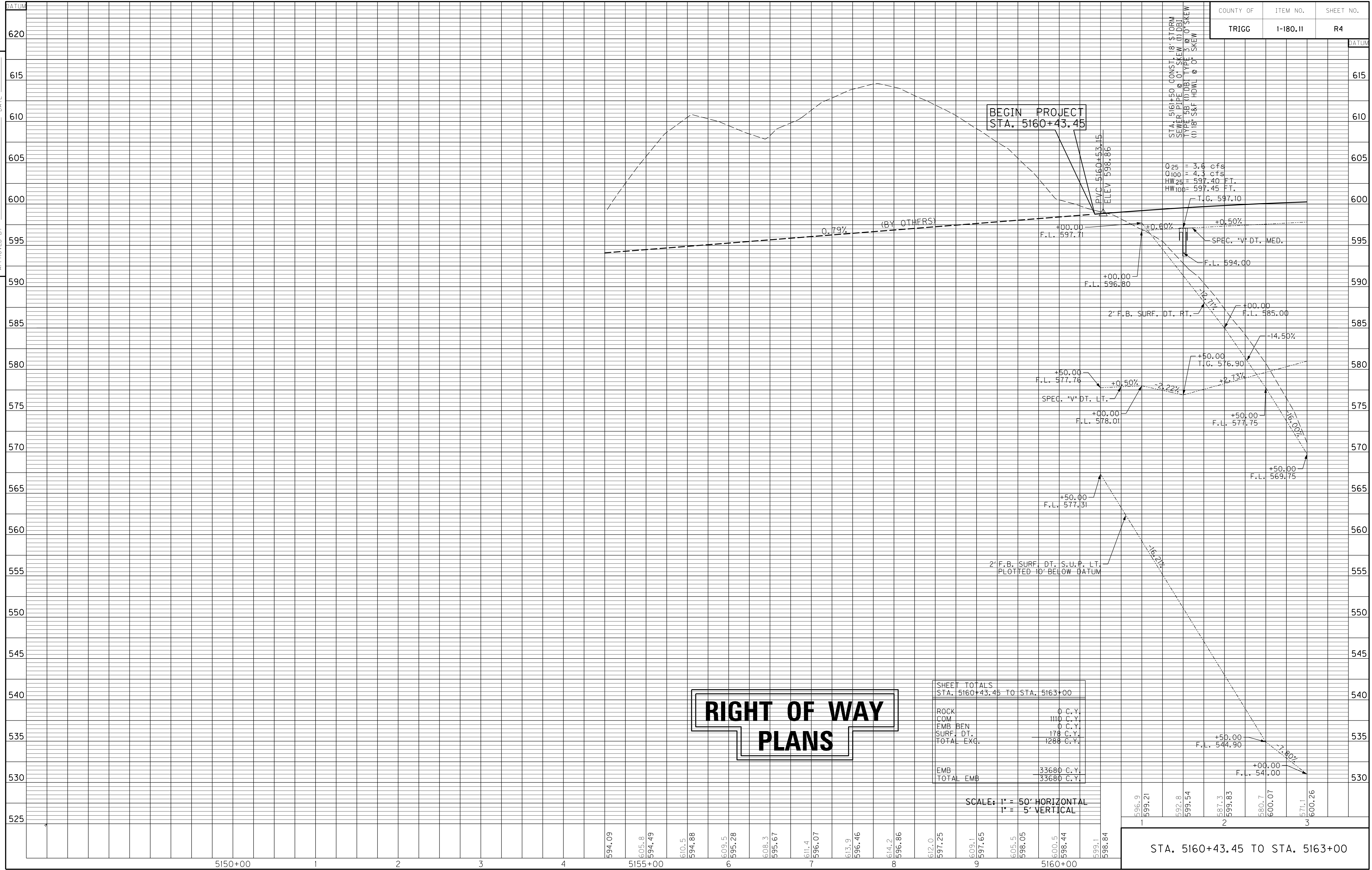

RIGHT OF WAY PLANS

SHEET TOTALS	
STA. 5160+43.45 TO STA. 5163+00	
ROCK	0 C.Y.
COM.	110 C.Y.
EMB. BEN.	0 C.Y.
SURF. DT.	178 C.Y.
TOTAL EXC.	1288 C.Y.
EMB.	33680 C.Y.
TOTAL EMB.	33680 C.Y.

SCALE: 1" = 50' HORIZONTAL
 1" = 5' VERTICAL

596.9	599.21	592.8	587.3	580.7	571.1
599.54	599.83	600.07	600.26		
STA. 5160+43.45 TO STA. 5163+00					

RIGHT OF WAY PLANS

PREPARED BY _____ DATE _____
 CHECKED BY _____ DATE _____
 APPROVED BY _____ DATE _____

DITCH CONSTRUCTION LT. C					
STA. TO STA.	SIZE/TYPE	CHANNEL LINING			
		TYPE	DEPTH	QUANTITY	T
5163+00 TO 5168+00	SPEC. "V"	ECB	1'	458 S.Y.	-
5168+00 TO 5170+50	SPEC. "V"	ECB	1'	365 S.Y.	-
5170+50 TO 5171+50	2' F.B. SURF.	CL. II	1'	45 T	15'
5171+50 TO 5175+00	2' F.B. SURF.	CL. II	1'	184 T	15'
5175+00 TO 5177+00	SPEC. "V"	ECB	1'	287 S.Y.	-

DITCH CONSTRUCTION SUP C					
STA. TO STA.	SIZE/TYPE	CHANNEL LINING			
		TYPE	DEPTH	QUANTITY	T
5163+12	OUTLET	CL. II	2'	13 T	15'
5163+00 TO 5165+50	2' F.B. SURF.	CL. II	1'	112 T	15'
5165+50 TO 5168+00	2' F.B. SURF.	ECB	1'	180 S.Y.	-
5168+00 TO 5169+00	SPEC. "V"	ECB	1'	92 S.Y.	-
5169+00 TO 5170+50	NORM.	ECB	1'	138 S.Y.	-
5171+50 TO 5172+50	2' F.B. SPEC.	ECB	1'	114 S.Y.	-
5172+50 TO 5174+00	2' F.B. SPEC.	ECB	1'	171 S.Y.	-
5174+00 TO 5175+42	2' F.B. SPEC.	CL. II	1'	93 T	15'
5175+34	OUTLET	CL. III	1'	20 T	24'

DITCH CONSTRUCTION MED. C					
STA. TO STA.	SIZE/TYPE	CHANNEL LINING			
		TYPE	DEPTH	QUANTITY	T
5163+00 TO 5165+00	SPEC. "V"	ECB	1'	270 S.Y.	-
5165+00 TO 5167+50	SPEC. "V"	ECB	1'	338 S.Y.	-
5167+50 TO 5168+50	NORM.	ECB	1'	135 S.Y.	-
5168+50 TO 5171+50	NORM.	ECB	1'	406 S.Y.	-
5171+50 TO 5176+50	NORM.	ECB	1'	677 S.Y.	-

PI STA 5176+30.68
 $\Delta = 53^{\circ}08'50"$ LT
 $T_s = 1735.826'$
 $L_s = 184.00'$
 $L_c = 2864.07'$
 $\theta_s = 1^{\circ}36'00"$ LT
 $LT = 122.67'$
 $ST = 61.34'$
 $R = 3286.00'$
 $E = 388.61'$
 $e = 4.6\%$
 Runoff = 184'
 Runout = 80'

FRONTAGE ROAD NO.1 LT.
 STA. 7+50 CONST. 12' ENTR.
 W/ 7 S.Y. APPROACH PVMT.
 & 105 S.Y. ENTR. PVMT.

FRONTAGE ROAD NO.1
 PI STA 8+07.56
 $\Delta = 67^{\circ}15'08"$ RT
 $T = 33.25'$
 $L = 58.69'$
 $R = 50.00'$
 $E = 10.05'$
 $e = NC$

ROGER L. HEARD
 & JOYCE S. HEARD

TIM FUTRELL

US 68 STA. 5177+49.11=
 AVERITT LUMBER RD. STA. 50+00.00=
 FRONTAGE ROAD NO.1 STA. 10+00.00

LT STA. 5163+00 TO STA. 5177+00
 CONST. 1381 LF OF WOVEN WIRE
 FENCE TYPE 1

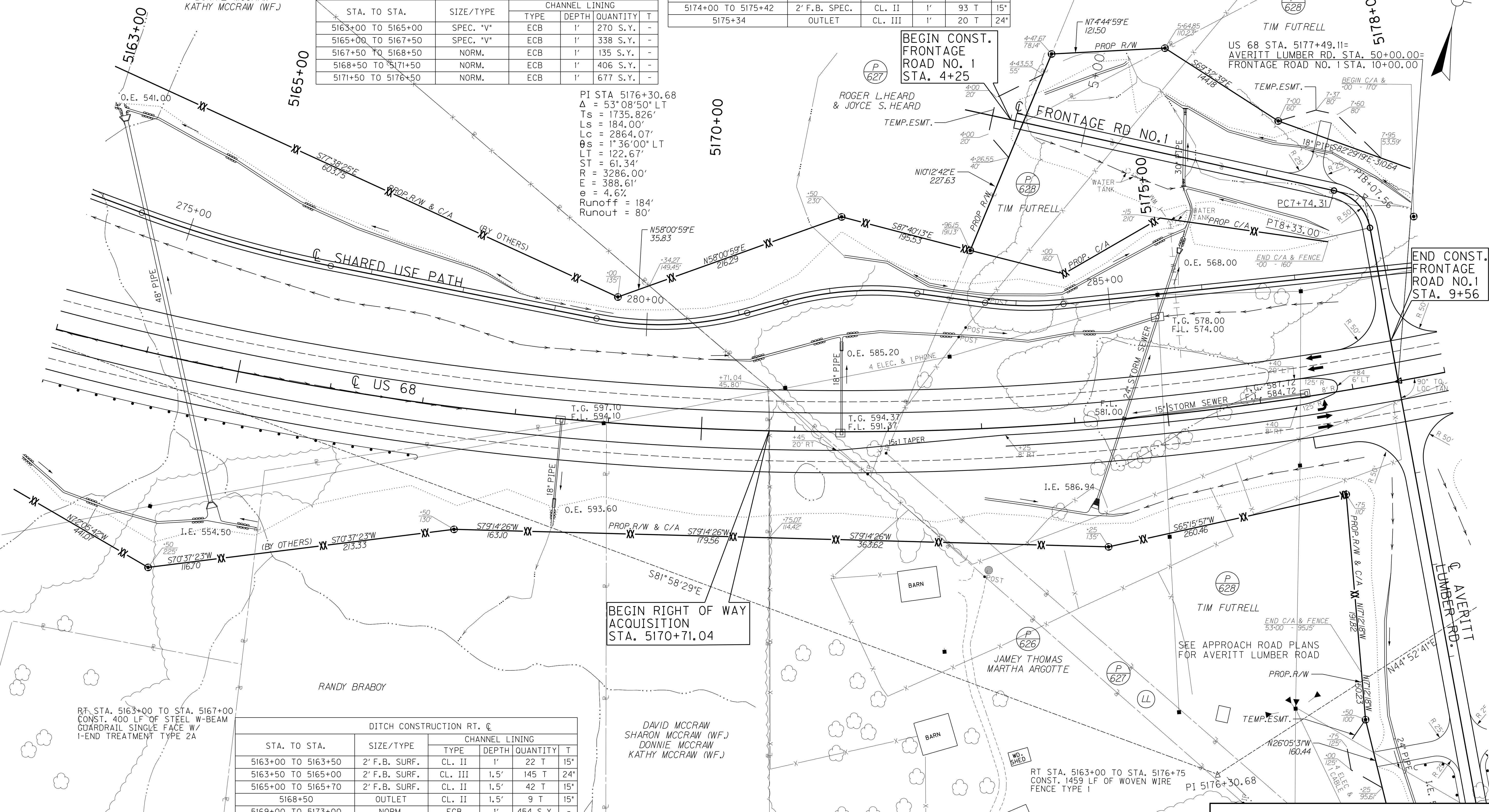

DITCH CONSTRUCTION RT. C					
STA. TO STA.	SIZE/TYPE	CHANNEL LINING			
		TYPE	DEPTH	QUANTITY	T
5163+00 TO 5163+50	2' F.B. SURF.	CL. II	1'	22 T	15'
5163+50 TO 5165+00	2' F.B. SURF.	CL. III	1.5'	145 T	24'
5165+00 TO 5165+70	2' F.B. SURF.	CL. II	1.5'	42 T	15'
5168+50	OUTLET	CL. II	1.5'	9 T	15'
5169+00 TO 5173+00	NORM.	ECB	1'	454 S.Y.	-
5173+00 TO 5174+15	2' F.B. SPEC.	ECB	1'	156 S.Y.	-
5174+15 TO 5177+00	SPEC. "V"	ECB	1'	304 S.Y.	-

RT STA. 5163+00 TO STA. 5167+00
 CONST. 400 LF OF STEEL W-BEAM
 GUARDRAIL SINGLE FACE W/
 I-END TREATMENT TYPE 2A

BEGIN RIGHT OF WAY
 ACQUISITION
 STA. 5170+71.04

BEGIN CONST.
 FRONTAGE
 ROAD NO. 1
 STA. 4+25

END CONST.
 FRONTAGE
 ROAD NO.1
 STA. 9+56

SCALE: 1"=50'

STA. 5163+00 TO STA. 5178+00

USER: \$\$\$USER\$\$\$
 DATE: \$\$\$DATE\$\$\$
 FILE NAME: \$\$\$designfilespecification\$\$\$
 E-SHEET NAME:

PREPARED BY _____ DATE _____
 CHECKED BY _____ DATE _____
 APPROVED BY _____ DATE _____

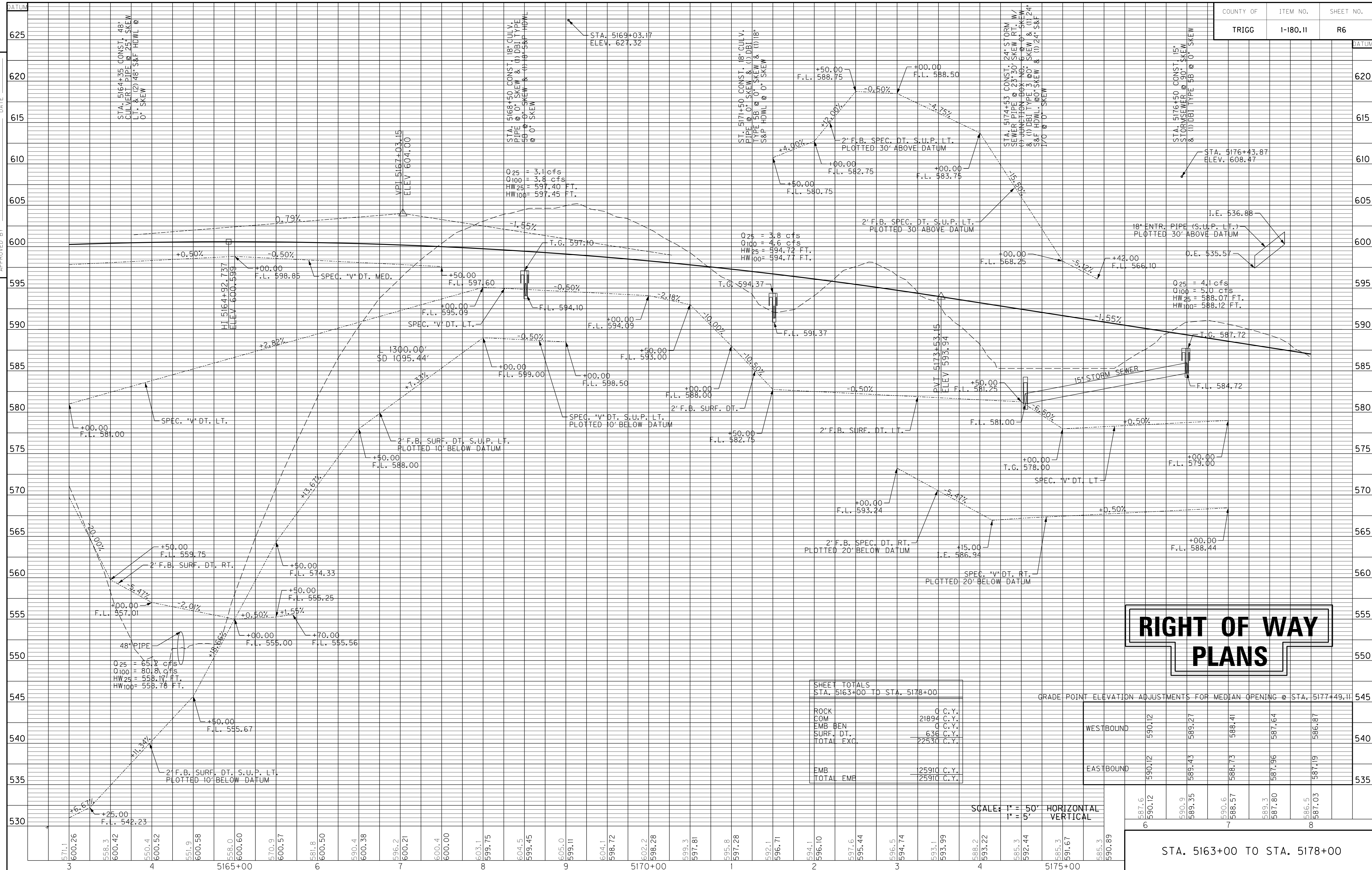

SHEET TOTALS	
STA. 5163+00 TO STA. 5178+00	
ROCK	0 C.Y.
COM	21894 C.Y.
EMB BEN	0 C.Y.
SURF. DT.	636 C.Y.
TOTAL EXC.	22530 C.Y.
EMB	25910 C.Y.
TOTAL EMB	25910 C.Y.

GRADE POINT ELEVATION ADJUSTMENTS FOR MEDIAN OPENING @ STA. 5177+49.11

	6	7	8
WESTBOUND	590.12	589.27	588.41
EASTBOUND	590.12	589.43	588.73
	590.6	588.57	587.96
	587.6	589.35	588.19
	590.12	589.35	588.19
	590.6	588.57	587.96
	587.6	589.35	588.19
	590.12	589.27	588.41
	590.6	588.57	587.96
	587.6	589.35	588.19

SCALE: 1" = 50' HORIZONTAL
 1" = 5' VERTICAL

STA. 5163+00 TO STA. 5178+00

USER: \$\$\$USER\$\$\$
 DATE: \$\$\$DATE\$\$\$
 FILE NAME: \$\$\$designfiles\$\$\$specifications\$\$\$
 E-SHEET NAME:

PREPARED BY _____ DATE _____
 CHECKED BY _____ DATE _____
 APPROVED BY _____ DATE _____

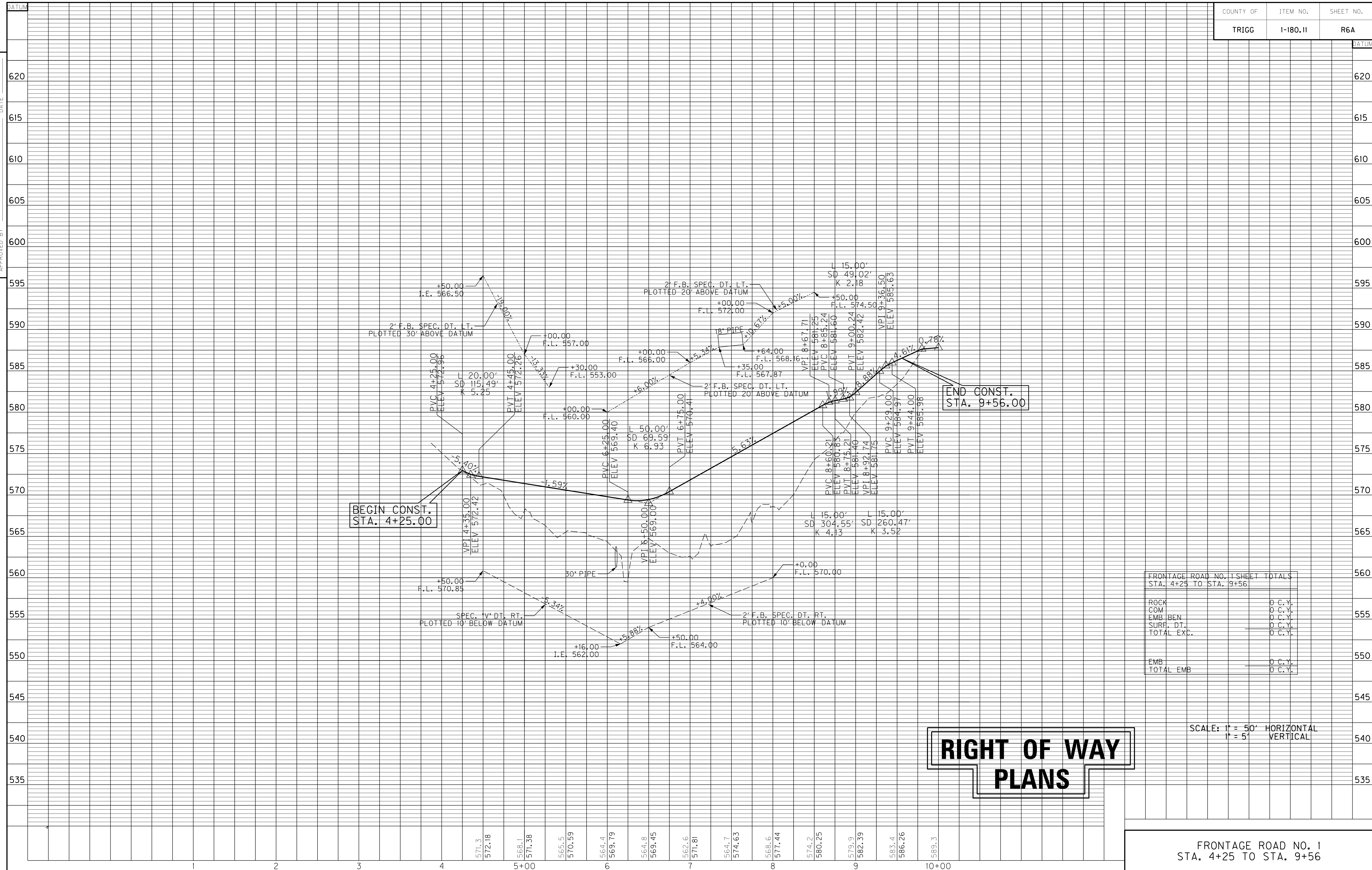

**BEGIN CONST.
STA. 4+25.00**

**RIGHT OF WAY
PLANS**

FRONTAGE ROAD NO. 1 SHEET TOTALS STA. 4+25 TO STA. 9+56	
ROCK	0 C.Y.
COM	0 C.Y.
EMB BEN	0 C.Y.
SURF. DT.	0 C.Y.
TOTAL EXC.	0 C.Y.
EMB	0 C.Y.
TOTAL EMB	0 C.Y.

SCALE: 1" = 50' HORIZONTAL
1" = 5' VERTICAL

FRONTAGE ROAD NO. 1
STA. 4+25 TO STA. 9+56

USER: \$\$\$USER\$\$\$
 DATE: \$\$\$DATE\$\$\$
 FILE NAME: \$\$\$designsfiles\$\$\$specifications\$\$\$
 E-SHEET NAME:

RIGHT OF WAY PLANS

DITCH CONSTRUCTION SUP. ☐					
STA. TO STA.	SIZE/TYPE	CHANNEL LINING			
		TYPE	DEPTH	QUANTITY	T
5178+00 TO 5182+00	SPEC. "V"	ECB	1'	314 S.Y.	-
5182+00 TO 5185+00	NORM.	ECB	1'	234 S.Y.	-
5185+00 TO 5188+00	2' F.B. SPEC.	CL. II	1'	167 T	15'
5188+00 TO 4118+31	2' F.B. SPEC.	ECB	1'	217 S.Y.	-
4119+00 TO 4120+00	2' F.B. SPEC.	ECB	1'	114 S.Y.	-

DITCH CONSTRUCTION MED. ☐					
STA. TO STA.	SIZE/TYPE	CHANNEL LINING			
		TYPE	DEPTH	QUANTITY	T
5178+50 TO 5183+00	NORM.	ECB	1'	608 S.Y.	-
5183+00 TO 4117+50	NORM.	ECB	1'	993 S.Y.	-
4119+50 TO 4120+00	NORM.	ECB	1'	68 S.Y.	-

DITCH CONSTRUCTION LT. ☐						
STA. TO STA.	SIZE/TYPE	CHANNEL LINING				
		TYPE	DEPTH	QUANTITY	T	
5178+00 TO 5180+00	SPEC. "V"	ECB	1'	359 S.Y.	-	
5180+00 TO 5185+50	NORM.	ECB	1'	624 S.Y.	-	
5185+50 TO 5188+00	2' F.B. SPEC.	ECB	1'	285 S.Y.	-	
5188+00 TO 4118+10	2' F.B. SPEC.	ECB	1'	227 S.Y.	-	
4119+17 TO 4120+00	2' F.B. SPEC.	ECB	1'	174 S.Y.	-	

PREPARED BY _____ DATE _____
 CHECKED BY _____ DATE _____
 APPROVED BY _____ DATE _____

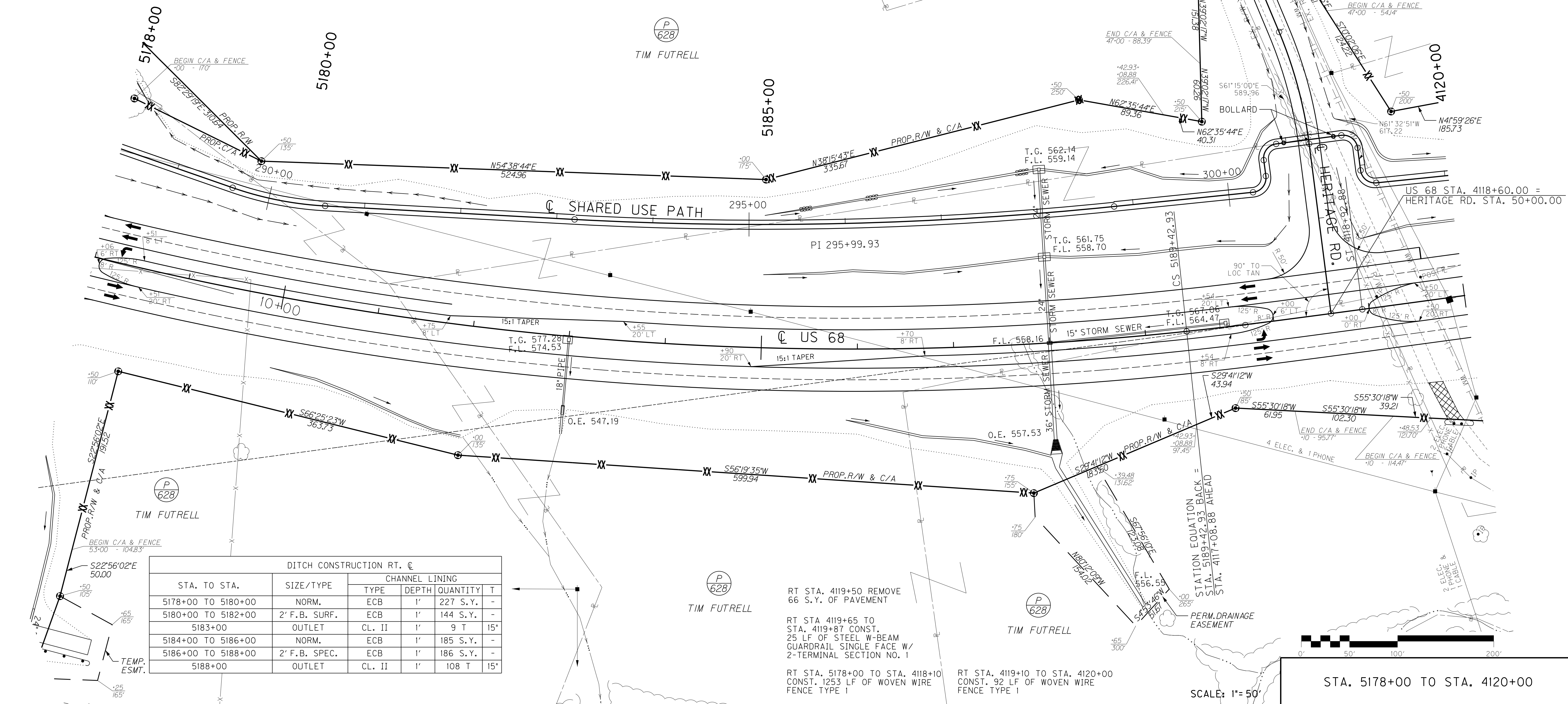

DITCH CONSTRUCTION RT. ☐					
STA. TO STA.	SIZE/TYPE	CHANNEL LINING			
		TYPE	DEPTH	QUANTITY	T
5178+00 TO 5180+00	NORM.	ECB	1'	227 S.Y.	-
5180+00 TO 5182+00	2' F.B. SURF.	ECB	1'	144 S.Y.	-
5183+00	OUTLET	CL. II	1'	9 T	15'
5184+00 TO 5186+00	NORM.	ECB	1'	185 S.Y.	-
5186+00 TO 5188+00	2' F.B. SPEC.	ECB	1'	186 S.Y.	-
5188+00	OUTLET	CL. II	1'	108 T	15'

USER: \$\$\$USER\$\$\$
 DATE: \$\$\$DATE\$\$\$
 FILE NAME: \$\$\$designsfilespecifications\$\$\$
 E-SHEET NAME:



SCALE: 1"=50'

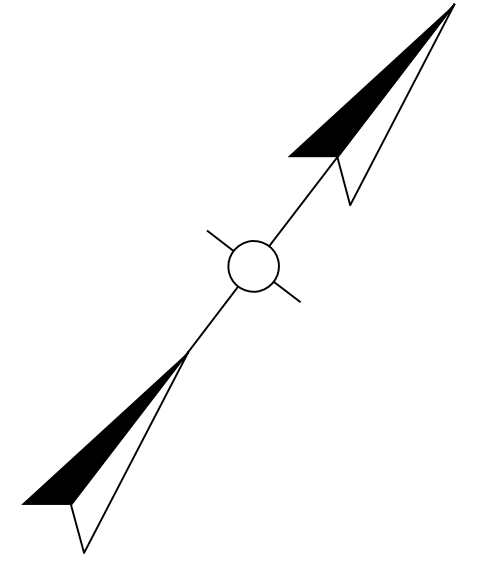

PREPARED BY _____ DATE _____
 CHECKED BY _____ DATE _____
 APPROVED BY _____ DATE _____

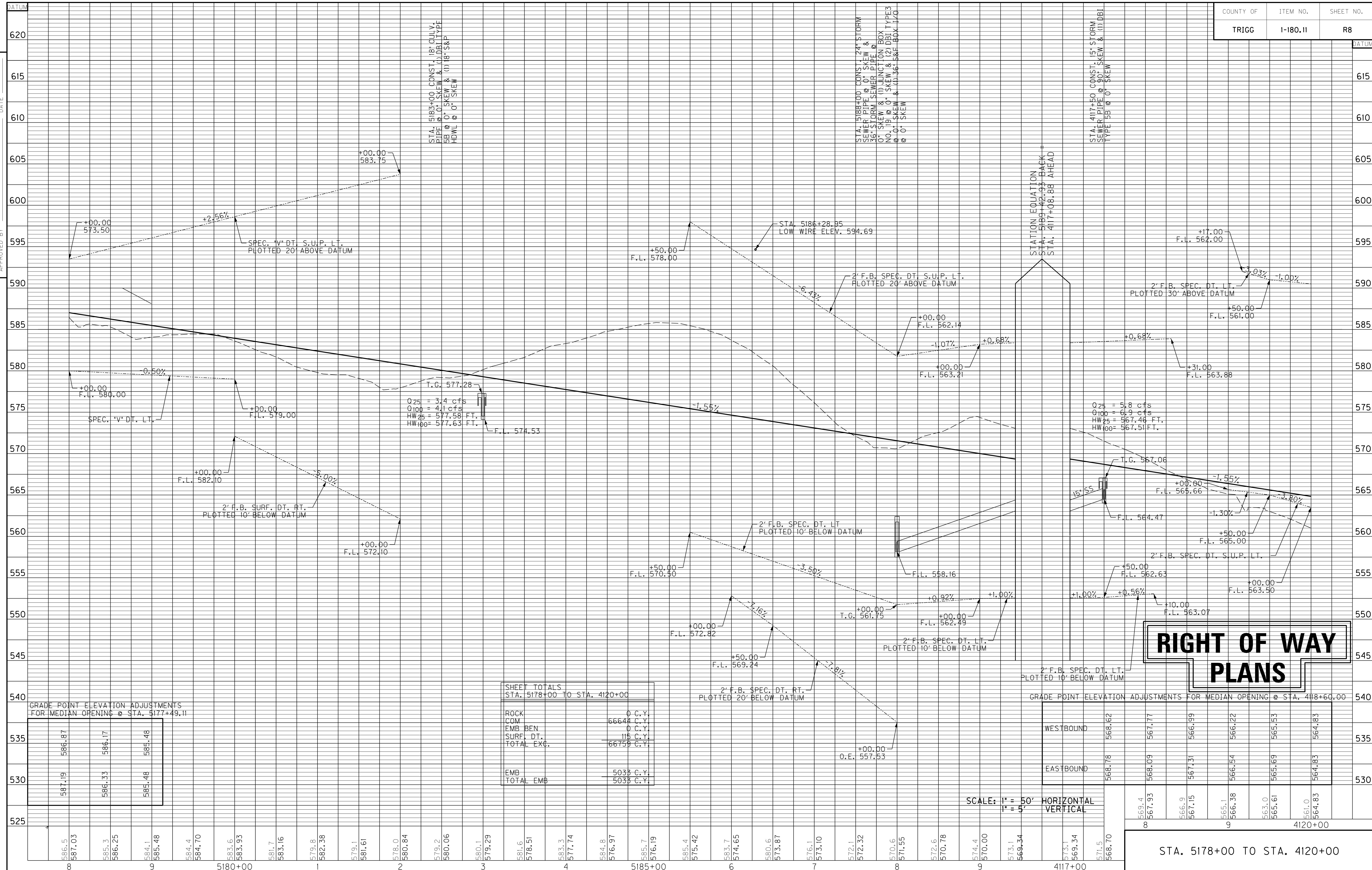

SHEET TOTALS STA. 5178+00 TO STA. 4120+00	
ROCK	0 C.Y.
COM.	66644 C.Y.
EMB BEN	0 C.Y.
SURF DT.	115 C.Y.
TOTAL EXC.	66759 C.Y.
EMB	5033 C.Y.
TOTAL EMB	5033 C.Y.

GRADE POINT ELEVATION ADJUSTMENTS FOR MEDIAN OPENING @ STA. 5177+49.11

586.5	587.19	586.87
587.03	586.33	586.17
585.3	586.25	585.48
584.1	585.48	585.48

GRADE POINT ELEVATION ADJUSTMENTS FOR MEDIAN OPENING @ STA. 4118+60.00

WESTBOUND	568.62	567.77	566.99	566.22	565.53	564.83
EASTBOUND	568.78	568.09	567.31	566.54	565.69	564.83

SCALE: 1" = 50' HORIZONTAL
 1" = 5' VERTICAL

**RIGHT OF WAY
PLANS**

STA. 5178+00 TO STA. 4120+00

DITCH CONSTRUCTION SUP. @					
STA. TO STA.	SIZE/TYPE	CHANNEL LINING			
		TYPE	DEPTH	QUANTITY	T
4120+00 TO 4124+00	2' F.B. SPEC.	ECB	1'	435 S.Y.	-
4124+00 TO 4124+80	2' F.B. SPEC.	CL. II	1'	46 T	15'
4124+80 TO 4131+20	2' F.B. SPEC.	ECB	1'	595 S.Y.	-
4132+05 TO 4134+07	2' F.B. SPEC.	ECB	1'	217 S.Y.	-
4134+07 TO 4135+00	SPEC. "V"	ECB	1'	92 S.Y.	-

DITCH CONSTRUCTION MED. @					
STA. TO STA.	SIZE/TYPE	CHANNEL LINING			
		TYPE	DEPTH	QUANTITY	T
4120+00 TO 4121+00	NORM.	ECB	1'	135 S.Y.	-
4121+00 TO 4126+50	NORM.	ECB	1'	743 S.Y.	-
4126+50 TO 4129+00	SPEC. "V"	ECB	1'	365 S.Y.	-
4129+00 TO 4130+75	SPEC. "V"	ECB	1'	237 S.Y.	-
4132+50 TO 4135+00	NORM.	ECB	1'	376 S.Y.	-

DITCH CONSTRUCTION LT. @					
STA. TO STA.	SIZE/TYPE	CHANNEL LINING			
		TYPE	DEPTH	QUANTITY	T
4120+00 TO 4124+00	2' F.B. SPEC.	ECB	1'	685 S.Y.	-
4124+00 TO 4125+20	2' F.B. SPEC.	CL. II	1'	126 T	15'
4125+20	OUTLET	CL. III	1'	24 T	24'
4125+20 TO 4131+00	SPEC. "V"	ECB	1'	594 S.Y.	-
4132+00 TO 4134+23	SPEC. "V"	ECB	1'	204 S.Y.	-
4134+23	OUTLET	ECB	1.5'	13 T	15'
4134+23 TO 4135+00	2' F.B. SPEC.	ECB	1'	87 S.Y.	-

DITCH CONSTRUCTION WARRENTON SCHOOL RD. RT.					
STA. TO STA.	SIZE/TYPE	CHANNEL LINING			
		TYPE	DEPTH	QUANTITY	T
45+00 TO 45+50	NORM.	ECB	1'	35 S.Y.	-
45+50 TO 46+00	SPEC. "V"	ECB	1'	35 S.Y.	-
46+00 TO 46+50	NORM.	ECB	1'	35 S.Y.	-
47+00 TO 48+50	2' F.B. SPEC.	ECB	1'	139 S.Y.	-

DITCH CONSTRUCTION WARRENTON SCHOOL RD. LT.					
STA. TO STA.	SIZE/TYPE	CHANNEL LINING			
		TYPE	DEPTH	QUANTITY	T
47+00 TO 48+55	2' F.B. SPEC.	ECB	1'	156 S.Y.	-

LT. STA. 4131+30 CONST. 1 BOLLARD
138 FT LEFT OF U.S. 68 MAINLINE

LT. STA. 4131+80 CONST. 1 BOLLARD
135 FT LEFT OF U.S. 68 MAINLINE

WARRENTON SCHOOL ROAD
RT. STA. 46+65 CONST. 12'
ENTRANCE W/ 9 S.Y. OF APPR.
RD. PVMT. & 67 S.Y. OF
ENTRANCE PVMT.

WARRENTON SCHOOL ROAD
LT. STA. 46+55 CONST. 20'
ENTRANCE W/ 11 S.Y. OF APPR.
RD. PVMT. & 57 S.Y. OF
ENTRANCE PVMT.

LT. STA. 4120+00 TO STA. 4131+67
CONST. 1231 LF OF WOVEN WIRE
FENCE TYPE I

LT. STA. 4132+00 TO STA. 4135+00
CONST. 350 LF OF WOVEN WIRE
FENCE TYPE I

WARRENTON SCHOOL ROAD
STA. 45+00 CONST. 10 LF
EDGE KEY

BEGIN CONST.
WARRENTON SCHOOL RD.
STA. 45+00.00

WARRENTON SCL. RD.
PI STA 45+94.16
Δ = 20° 40' 20" RT
T = 62.37'
L = 123.39'
R = 342.00'
E = 5.64'
e = 4.84%
Runoff = 80'
Runout = 33'

PREPARED BY _____ DATE _____
CHECKED BY _____ DATE _____
APPROVED BY _____ DATE _____

LAYTON R. LAWRENCE
PATSY D. LAWRENCE (WF.)

LARRY DAVID LAWRENCE
BETTY LAWRENCE (WF.)
WILLIAM DENNIS LAWRENCE
BARBARA JEAN LAWRENCE (WF.)

WARRENTON SCHOOL RD.
PI STA 47+34.10
Δ = 76° 33' 23" LT
T = 78.91'
L = 133.62'
R = 100'
E = 27.37'
e = 7.69%
Runoff = 130'
Runout = 33' N33°24'37"E
37.90

END CONST.
WARRENTON SCHOOL RD.
STA. 49+56

WILLIAM D. LAWRENCE
DENNIS B. LAWRENCE
BLY GOLLADAY
GLENDA B. LAWRENCE
LARRY D. LAWRENCE

RT. STA. 4125+50 TO STA.
4131+19 CONSTRUCT CHANNEL
CHANGE NO. 1 W/ 935 T OF CL. II
CHANNEL LINING

DITCH CONSTRUCTION RT. @					
STA. TO STA.	SIZE/TYPE	CHANNEL LINING			
		TYPE	DEPTH	QUANTITY	T
4121+00 TO 4125+00	2' F.B. SURF.	ECB	1'	288 S.Y.	-
4126+70	OUTLET	CL. II	1'	39 T	15'
4129+00	OUTLET	CL. II	1'	5 T	15'
4132+00 TO 4133+50	2' F.B. SURF.	ECB	1'	108 S.Y.	-
4134+69	OUTLET	CL. II	1'	27 T	15'
4134+76 TO 4135+00	3' F.B. SURF.	ECB	1.5'	26 S.Y.	-

PI STA 4128+79.81
Δ = 11° 16' 56" RT
Ts = 631.43'
Ls = 275.00'
Lc = 709.55'
θs = 1° 34' 00" RT
LT = 183.34'
ST = 91.67'
R = 5000.00'
E = 24.97'
e = 3.2%
Runoff = 275
Runout = 171.88

RT STA. 4120+00 TO STA. 4131+00
CONST. 1116 LF OF WOVEN WIRE
FENCE TYPE I

RT STA. 4132+25 TO STA. 4135+00
CONST. 275 LF OF WOVEN WIRE
FENCE TYPE I

RT STA 4131+55 CONST.
16' ENTRANCE W/
42 S.Y. OF MAINLINE PVMT. &
244 S.Y. OF ENTRANCE PVMT.

RIGHT OF WAY PLANS

USER: \$\$\$USER\$\$\$\$
DATE: \$\$\$DATE\$\$\$\$
FILE NAME: \$\$\$designsfiles\$specifications\$\$\$
E-SHEET NAME:

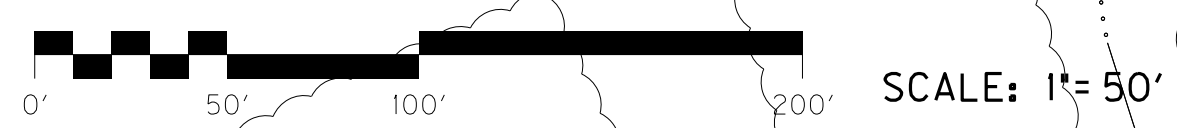

STA. 4120+00 TO STA. 4135+00

RIGHT OF WAY PLANS

PREPARED BY _____ DATE _____
 CHECKED BY _____ DATE _____
 APPROVED BY _____ DATE _____

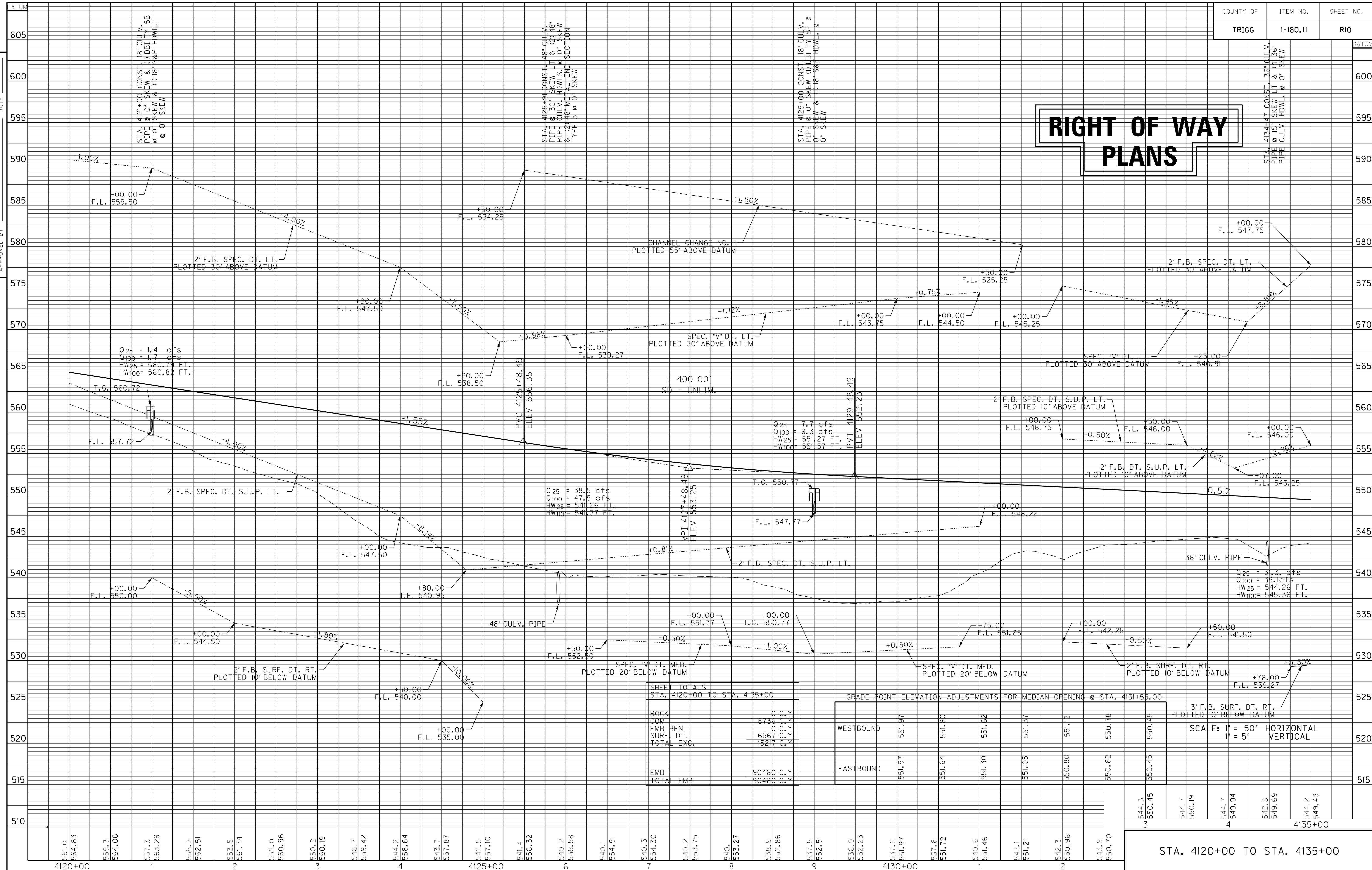

SHEET TOTALS STA. 4120+00 TO STA. 4135+00	
ROCK COM.	8736 C.Y.
EMB. BEN.	0 C.Y.
SURF. DT.	6567 C.Y.
TOTAL EXC.	15217 C.Y.
EMB.	90460 C.Y.
TOTAL EMB.	90460 C.Y.

GRADE POINT ELEVATION ADJUSTMENTS FOR MEDIAN OPENING @ STA. 4131+55.00					
	WESTBOUND	551.97	551.80	551.82	551.87
	EASTBOUND	551.97	551.64	551.30	551.05
		550.80	550.62	550.78	550.45
		544.3	550.45	550.45	550.45

3' F.B. SURF. DT. RT.
 PLOTTED 10' BELOW DATUM
 SCALE: 1" = 50' HORIZONTAL
 1" = 5' VERTICAL

USER: \$\$\$USER\$\$\$
 DATE: \$\$\$DATE\$\$\$
 FILE NAME: \$\$\$designsfiles\$\$\$
 E-SHEET NAME:

STA. 4120+00 TO STA. 4135+00

PREPARED BY _____ DATE _____
 CHECKED BY _____ DATE _____
 APPROVED BY _____ DATE _____

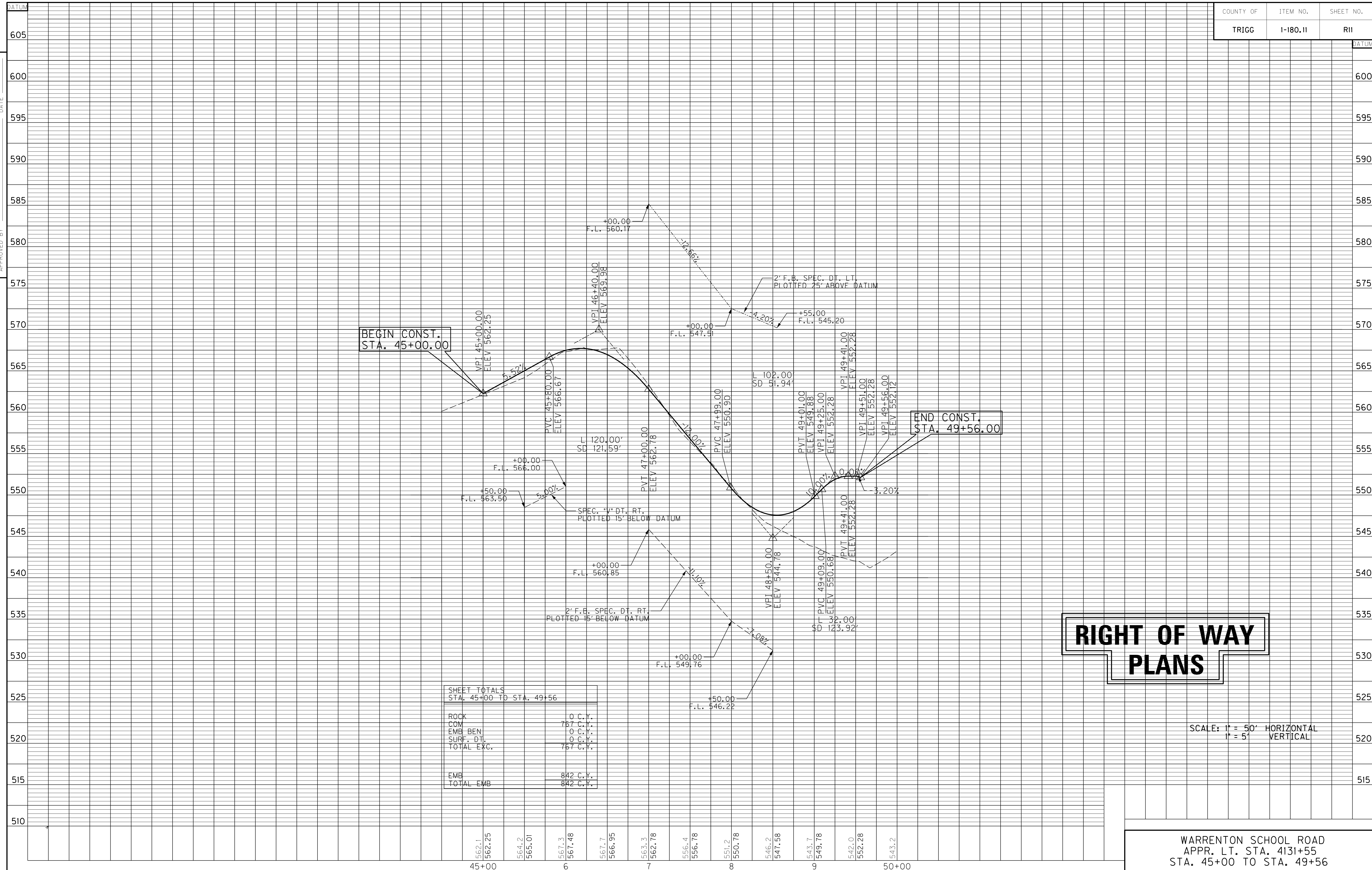

**BEGIN CONST.
STA. 45+00.00**

**END CONST.
STA. 49+56.00**

**RIGHT OF WAY
PLANS**

SHEET TOTALS	
STA. 45+00 TO STA. 49+56	
ROCK	0 C.Y.
COM	767 C.Y.
EMB BEN	0 C.Y.
SURF. DT.	0 C.Y.
TOTAL EXC.	767 C.Y.
EMB	842 C.Y.
TOTAL EMB	842 C.Y.

SCALE: 1" = 50' HORIZONTAL
1" = 5' VERTICAL

WARRENTON SCHOOL ROAD
APPR. LT. STA. 4131+55
STA. 45+00 TO STA. 49+56

USER: \$\$\$USER\$\$\$
 DATE: \$\$\$DATE\$\$\$
 FILE NAME: \$\$\$designsfiles\$\$\$specifications\$\$\$
 E-SHEET NAME:

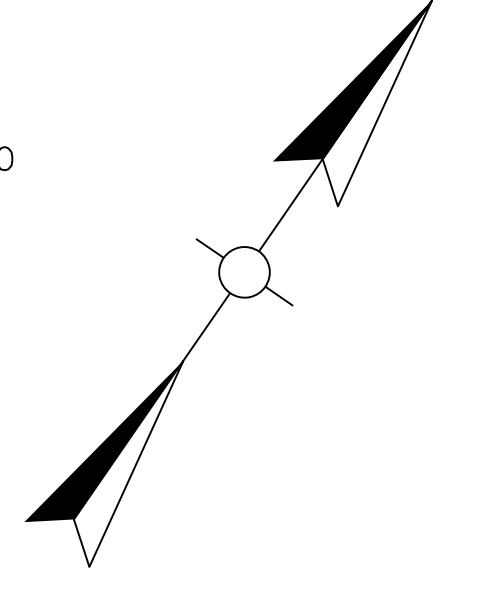

RIGHT OF WAY PLANS

PREPARED BY _____ DATE _____
 CHECKED BY _____ DATE _____
 APPROVED BY _____ DATE _____

DITCH CONSTRUCTION SUP @					
STA. TO STA.	SIZE/TYPE	CHANNEL LINING			
		TYPE	DEPTH	QUANTITY	T
4135+00 TO 4136+50	SPEC. "V"	ECB	1'	106 S.Y.	-
4136+50 TO 4137+77	SPEC. "V"	ECB	1'	90 S.Y.	-
4137+77 TO 4144+35	SPEC. "V"	ECB	1'	528 S.Y.	-
4144+65 TO 4146+00	NORM.	ECB	1'	106 S.Y.	-
4146+00 TO 4150+00	2' F.B. SPEC.	ECB	1'	382 S.Y.	-

DITCH CONSTRUCTION LT. @					
STA. TO STA.	SIZE/TYPE	CHANNEL LINING			
		TYPE	DEPTH	QUANTITY	T
4135+00 TO 4138+00	SPEC. "V"	ECB	1'	538 S.Y.	-
4138+00 TO 4144+20	NORM.	ECB	1'	781 S.Y.	-
4144+80 TO 4146+00	NORM.	ECB	1'	149 S.Y.	-
4146+00 TO 4150+00	2' F.B. SPEC.	ECB	1'	553 S.Y.	-

DITCH CONSTRUCTION MED. @					
STA. TO STA.	SIZE/TYPE	CHANNEL LINING			
		TYPE	DEPTH	QUANTITY	T
4135+00 TO 4136+50	NORM.	ECB	1'	203 S.Y.	-
4136+50 TO 4137+00	NORM.	ECB	1'	68 S.Y.	-
4137+70 TO 4141+50	SPEC. "V"	ECB	1'	658 S.Y.	-
4141+50 TO 4143+50	NORM.	ECB	1'	270 S.Y.	-
4145+50 TO 4147+50	NORM.	ECB	1'	338 S.Y.	-
4147+50 TO 4150+00	NORM.	ECB	1'	338 S.Y.	-

LT STA. 4144+50 CONST.
 16' ENTRANCE W/
 84 S.Y. OF MAINLINE PVMT. &
 366 S.Y. OF ENTRANCE PVMT.
 & 64 LF 18" ENTR PIPE

LT STA. 4135+00 TO STA. 4144+00
 CONST. 900 LF OF WOVEN WIRE
 FENCE TYPE I

LT STA. 4145+00 TO STA. 4150+00
 CONST. 487 LF OF WOVEN WIRE
 FENCE TYPE I

PI STA 4154+80.38
 $\Delta = 24^\circ 14' 19''$ LT
 $T_s = 846.32'$
 $L_s = 275.00'$
 $L_c = 1121.04'$
 $\theta_s = 2^\circ 23' 00''$ LT
 $LT = 183.35'$
 $ST = 91.68'$
 $R = 3300.00'$
 $E = 76.20'$
 $e = 4.64\%$
 Runoff = 275
 Runout = 118.53

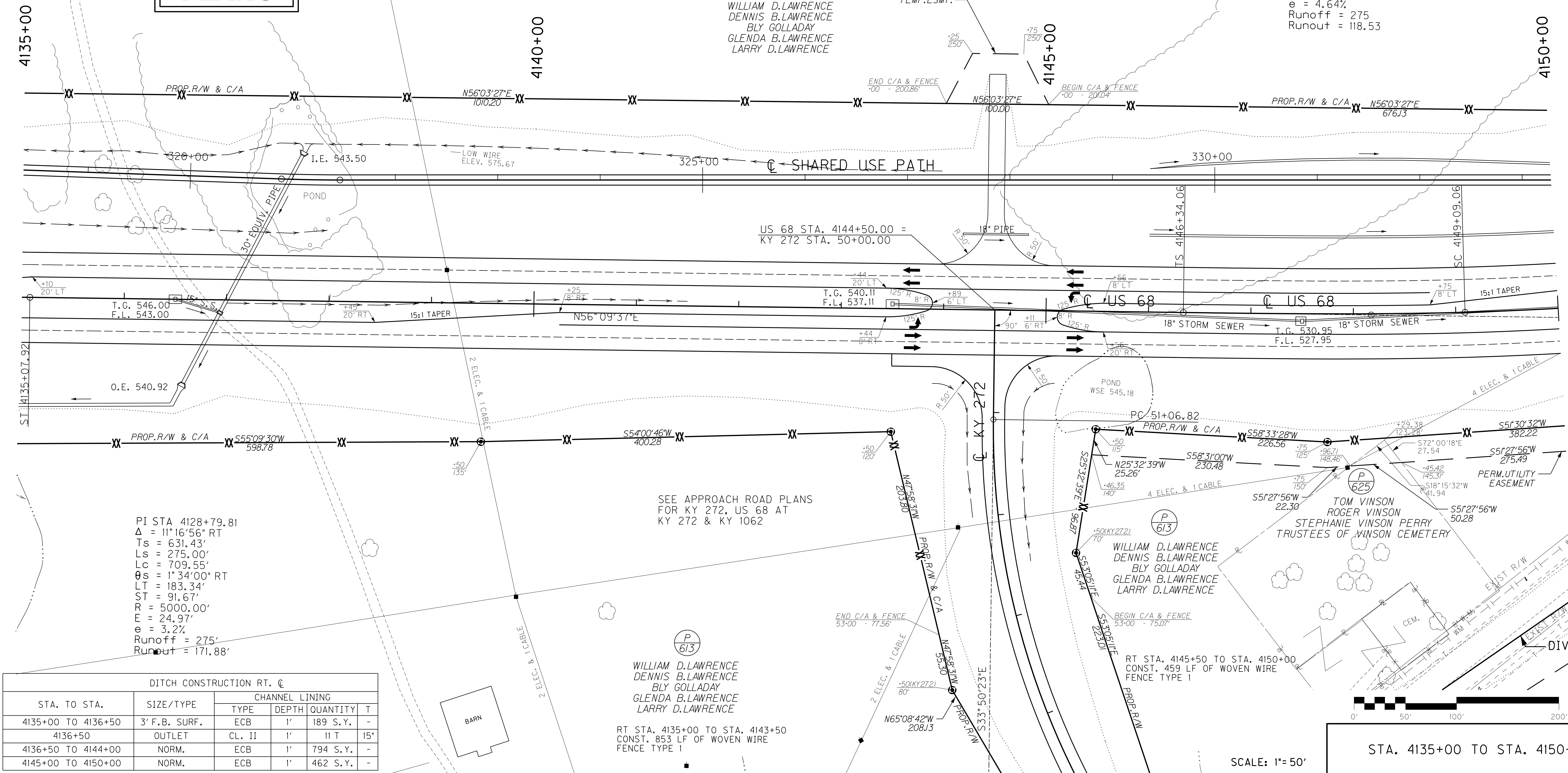

WILLIAM D. LAWRENCE
 DENNIS B. LAWRENCE
 BLY GOLLADAY
 GLENDA B. LAWRENCE
 LARRY D. LAWRENCE

SEE APPROACH ROAD PLANS
 FOR KY 272, US 68 AT
 KY 272 & KY 1062

WILLIAM D. LAWRENCE
 DENNIS B. LAWRENCE
 BLY GOLLADAY
 GLENDA B. LAWRENCE
 LARRY D. LAWRENCE

RT STA. 4135+00 TO STA. 4143+50
 CONST. 853 LF OF WOVEN WIRE
 FENCE TYPE I

PI STA 4128+79.81
 $\Delta = 11^\circ 16' 56''$ RT
 $T_s = 631.43'$
 $L_s = 275.00'$
 $L_c = 709.55'$
 $\theta_s = 1^\circ 34' 00''$ RT
 $LT = 183.34'$
 $ST = 91.67'$
 $R = 5000.00'$
 $E = 24.97'$
 $e = 3.2\%$
 Runoff = 275
 Runout = 171.88'

DITCH CONSTRUCTION RT. @					
STA. TO STA.	SIZE/TYPE	CHANNEL LINING			
		TYPE	DEPTH	QUANTITY	T
4135+00 TO 4136+50	3' F.B. SURF.	ECB	1'	189 S.Y.	-
4136+50	OUTLET	CL. II	1'	11 T	15'
4136+50 TO 4144+00	NORM.	ECB	1'	794 S.Y.	-
4145+00 TO 4150+00	NORM.	ECB	1'	462 S.Y.	-

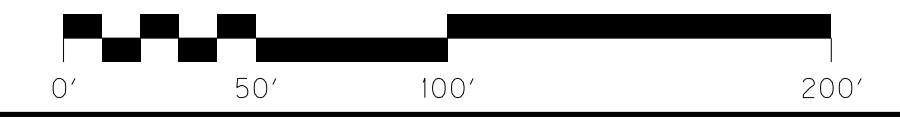

SCALE: 1"=50'

STA. 4135+00 TO STA. 4150+00

USER: \$\$\$USER\$\$\$
 DATE: \$\$\$DATE\$\$\$
 FILE NAME: \$\$\$designsfiles\$\$\$specifications\$\$\$
 E-SHEET NAME:

PREPARED BY _____ DATE _____
 CHECKED BY _____ DATE _____
 APPROVED BY _____ DATE _____

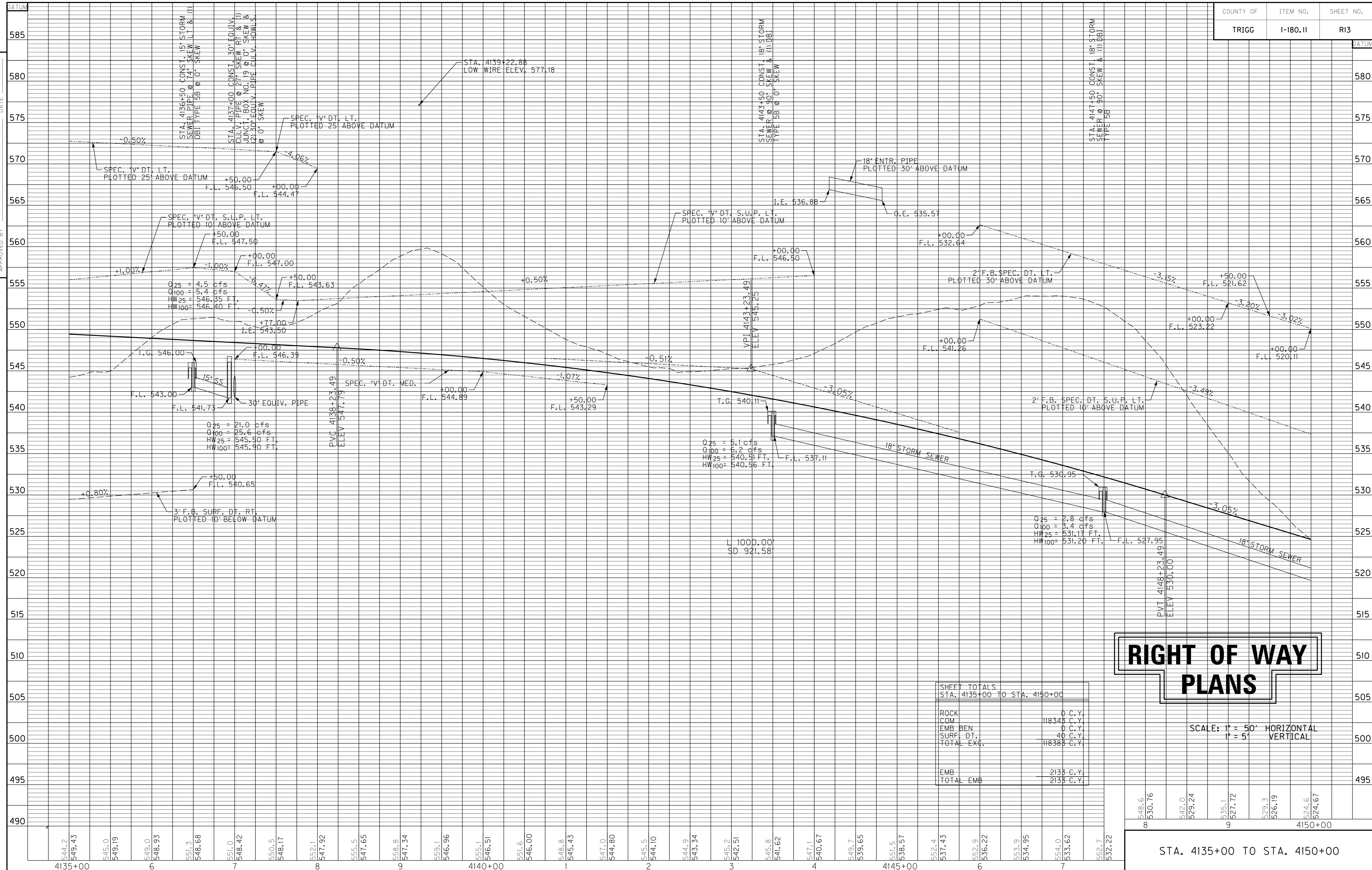

SHEET TOTALS	
STA. 4135+00 TO STA. 4150+00	
ROCK	0 C.Y.
COM.	118345 C.Y.
EMB. BEN.	0 C.Y.
SURF. DT.	40 C.Y.
TOTAL EXC.	118385 C.Y.
EMB.	2135 C.Y.
TOTAL EMB.	2135 C.Y.

RIGHT OF WAY PLANS

SCALE: 1" = 50' HORIZONTAL
1" = 5' VERTICAL

STA. 4135+00 TO STA. 4150+00

USER: \$\$\$USER\$\$\$
 DATE: \$\$\$DATE\$\$\$
 FILE NAME: \$\$\$designsfiles\$\$\$specifications\$\$\$
 E-SHEET NAME:

PREPARED BY _____ DATE _____
 CHECKED BY _____ DATE _____
 APPROVED BY _____ DATE _____

DITCH CONSTRUCTION SUP. ☉						
STA. TO STA.	SIZE/TYPE	CHANNEL LINING			T	
		TYPE	DEPTH	QUANTITY		
4150+00 TO 4151+00	2' F.B. SPEC.	ECB	1'	93 S.Y.	-	
4151+00 TO 4153+29	2' F.B. SPEC.	CL. II	1'	103 T	15'	
4153+29 TO 4155+00	2' F.B. SPEC.	ECB	1'	159 S.Y.	-	
4155+00 TO 4156+50	SPEC. "V"	ECB	1'	106 S.Y.	-	
4156+50 TO 4157+00	2' F.B. SPEC.	CL. II	1'	22 T	15'	
4157+00 TO 4163+00	2' F.B. SPEC.	ECB	1'	600 S.Y.	-	
4163+00 TO 4163+75	2' F.B. SPEC.	CL. II	1'	44 T	15'	
4163+75 TO 4164+00	2' F.B. SPEC.	CL. II	1'	15 T	15'	
4164+00 TO 4165+00	2' F.B. SPEC.	ECB	1'	93 S.Y.	-	

DITCH CONSTRUCTION LT. ☉						
STA. TO STA.	SIZE/TYPE	CHANNEL LINING			T	
		TYPE	DEPTH	QUANTITY		
4150+00 TO 4153+70	2' F.B. SPEC.	ECB	1'	496 S.Y.	-	
4153+70 TO 4160+00	NORM.	ECB	1'	743 S.Y.	-	
4160+00 TO 4162+00	SPEC. "V"	ECB	1'	205 S.Y.	-	
4162+00 TO 4165+00	SPEC. "V"	ECB	1'	222 S.Y.	-	

LT STA. 4155+00 TO STA. 4156+50
 CONST. GRAVITY RETAINING WALL W/
 139.24 C.Y. OF CLASS "B" CONCRETE

LT STA. 4156+64 TO STA. 4156+75
 CONST. 25 LF OF STEEL W-BEAM
 GUARDRAIL SINGLE FACE W/
 2-TERMINAL SECTION NO. 1

U.S. 68 AT KY 1489 RT
 STA. 57+56 CONST. 12' ENTR.
 W/ 7 S.Y. APPROACH PVMT. &
 12 S.Y. ENTR. PVMT.

LT STA. 4150+00 TO STA. 4165+00
 CONST. 1470 LF OF WOVEN WIRE
 FENCE TYPE 1

PI STA 4154+80.38
 $\Delta = 24^\circ 14' 19''$ LT
 $T_s = 846.32'$
 $L_s = 275.00'$
 $L_c = 1121.04'$
 $\theta_s = 2^\circ 23' 00''$ LT
 $LT = 183.35'$
 $ST = 91.68'$
 $R = 3300.00'$
 $E = 76.20'$
 $e = 4.64\%$
 $Runoff = 275$
 $Runout = 118.53$

(P 608)
 CRAIG PERRY
 STEPHANIE PERRY (WF.)

SEE APPROACH ROAD
 PLANS FOR U.S. 68
 AT KY 1489

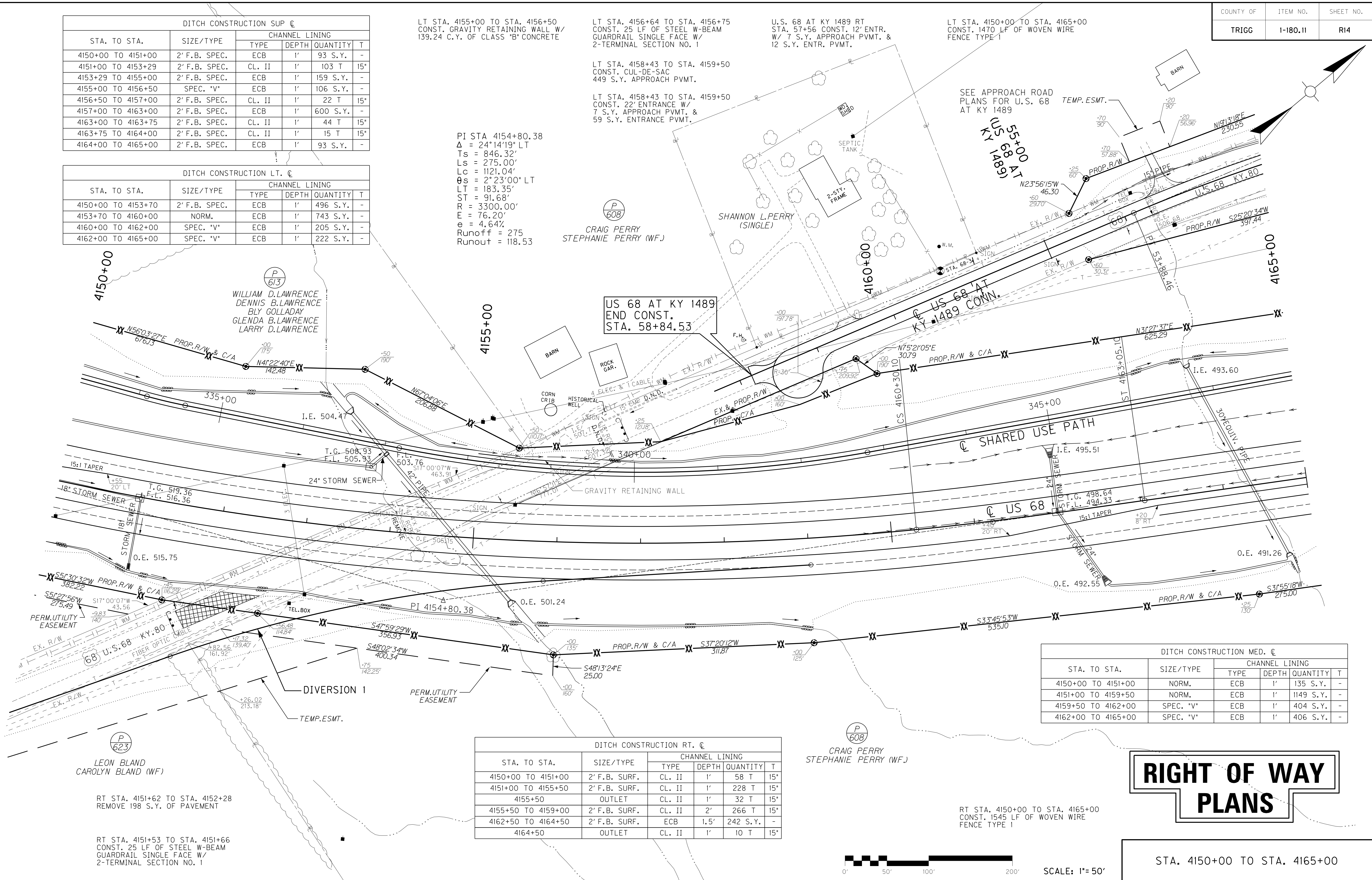

US 68 AT KY 1489
 END CONST.
 STA. 58+84.53

DITCH CONSTRUCTION MED. ☉						
STA. TO STA.	SIZE/TYPE	CHANNEL LINING			T	
		TYPE	DEPTH	QUANTITY		
4150+00 TO 4151+00	NORM.	ECB	1'	135 S.Y.	-	
4151+00 TO 4159+50	NORM.	ECB	1'	1149 S.Y.	-	
4159+50 TO 4162+00	SPEC. "V"	ECB	1'	404 S.Y.	-	
4162+00 TO 4165+00	SPEC. "V"	ECB	1'	406 S.Y.	-	

DITCH CONSTRUCTION RT. ☉						
STA. TO STA.	SIZE/TYPE	CHANNEL LINING			T	
		TYPE	DEPTH	QUANTITY		
4150+00 TO 4151+00	2' F.B. SURF.	CL. II	1'	58 T	15'	
4151+00 TO 4155+50	2' F.B. SURF.	CL. II	1'	228 T	15'	
4155+50	OUTLET	CL. II	1'	32 T	15'	
4155+50 TO 4159+00	2' F.B. SURF.	CL. II	2'	266 T	15'	
4162+50 TO 4164+50	2' F.B. SURF.	ECB	1.5'	242 S.Y.	-	
4164+50	OUTLET	CL. II	1'	10 T	15'	

(P 608)
 CRAIG PERRY
 STEPHANIE PERRY (WF.)

RT STA. 4151+62 TO STA. 4152+28
 REMOVE 198 S.Y. OF PAVEMENT

RT STA. 4151+53 TO STA. 4151+66
 CONST. 25 LF OF STEEL W-BEAM
 GUARDRAIL SINGLE FACE W/
 2-TERMINAL SECTION NO. 1

RT STA. 4150+00 TO STA. 4165+00
 CONST. 1545 LF OF WOVEN WIRE
 FENCE TYPE 1

RIGHT OF WAY PLANS

STA. 4150+00 TO STA. 4165+00



USER: \$\$\$USER\$\$\$
 DATE: \$\$\$DATE\$\$\$
 FILE NAME: \$\$\$designsfiles\$specifications\$\$\$
 E-SHEET NAME:

PREPARED BY _____ DATE _____
 CHECKED BY _____ DATE _____
 APPROVED BY _____ DATE _____

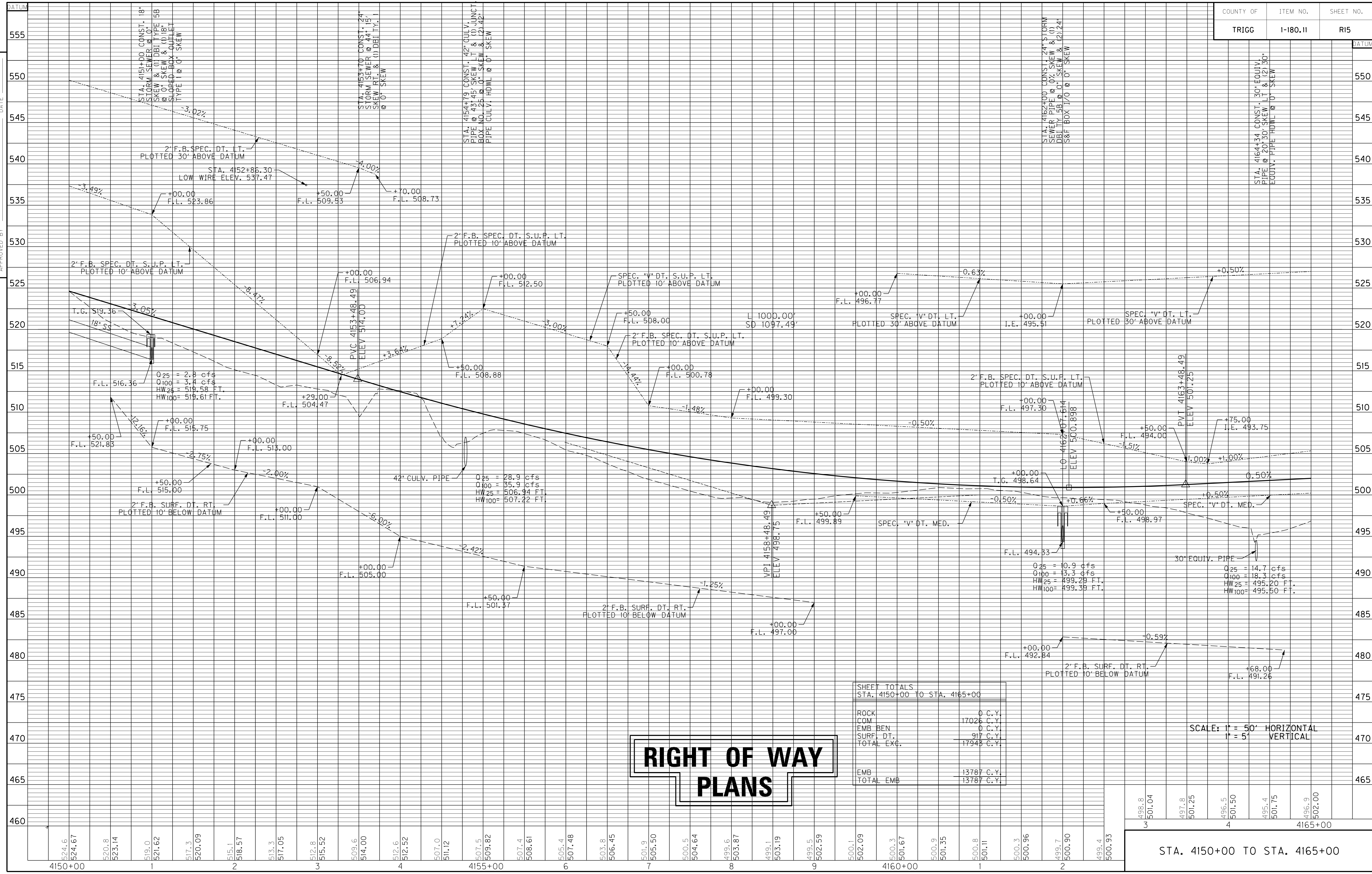

RIGHT OF WAY PLANS

SHEET TOTALS STA. 4150+00 TO STA. 4165+00	
ROCK	0 C.Y.
COM	17026 C.Y.
EMB. BEN	0 C.Y.
SURF. DT.	917 C.Y.
TOTAL EXC.	17943 C.Y.
EMB	13787 C.Y.
TOTAL EMB	13787 C.Y.

SCALE: 1" = 50' HORIZONTAL
 1" = 5' VERTICAL

STA. 4150+00 TO STA. 4165+00

USER: \$\$\$USER\$\$\$
 DATE: \$\$\$DATE\$\$\$
 FILE NAME: \$\$\$designfilespecifications\$\$\$
 E-SHEET NAME:

498.8	497.8	496.5	495.4	496.9
501.04	501.25	501.50	501.75	502.00
3	4			4165+00

PREPARED BY _____ DATE _____
 CHECKED BY _____ DATE _____
 APPROVED BY _____ DATE _____

STA. TO STA.	SIZE/TYPE	CHANNEL LINING			
		TYPE	DEPTH	QUANTITY	T
4165+00 TO 4167+00	2' F.B. SPEC.	ECB	1'	207 S.Y.	-
4168+00 TO 4169+67	SPEC. "V"	ECB	1'	153 S.Y.	-
4169+67 TO 4171+00	SPEC. "V"	ECB	1'	122 S.Y.	-
4179+50 TO 4180+00	2' F.B. SURF.	ECB	1.5'	48 S.Y.	-

STA. TO STA.	SIZE/TYPE	CHANNEL LINING			
		TYPE	DEPTH	QUANTITY	T
4165+00 TO 4167+00	SPEC. "V"	ECB	1'	270 S.Y.	-
4168+00 TO 4169+85	SPEC. "V"	ECB	1'	190 S.Y.	-
4169+85	OUTLET	CL. II	1'	16 T	15'
4169+85 TO 4174+00	SPEC. "V"	ECB	1'	425 S.Y.	-
4174+00 TO 4178+00	NORM.	ECB	1'	454 S.Y.	-
4178+00 TO 4180+00	2' F.B. SURF.	CL. II	1'	102 T	15'

STA. TO STA.	SIZE/TYPE	CHANNEL LINING			
		TYPE	DEPTH	QUANTITY	T
4165+00 TO 4166+50	SPEC. "V"	ECB	1'	203 S.Y.	-
4168+50 TO 4172+00	SPEC. "V"	ECB	1'	473 S.Y.	-
4172+00 TO 4180+00	NORM.	ECB	1'	1082 S.Y.	-

STA. TO STA.	SIZE/TYPE	CHANNEL LINING			
		TYPE	DEPTH	QUANTITY	T
4168+50	OUTLET	CL. II	1'	7 T	15'
4169+17	OUTLET	CL. II	1.5'	30 T	15'
4169+17 TO 4172+00	2' F.B. SPEC.	ECB	1'	204 S.Y.	-
4172+00 TO 4174+00	SPEC. "V"	ECB	1'	185 S.Y.	-
4174+00 TO 4178+50	NORM.	ECB	1'	416 S.Y.	-
4178+50 TO 4179+00	2' F.B. SURF.	ECB	1'	36 S.Y.	-
4179+00 TO 4180+00	2' F.B. SURF.	CL. II	1'	45 T	15'

RIGHT OF WAY PLANS

STA. 4165+00 TO STA. 4180+00

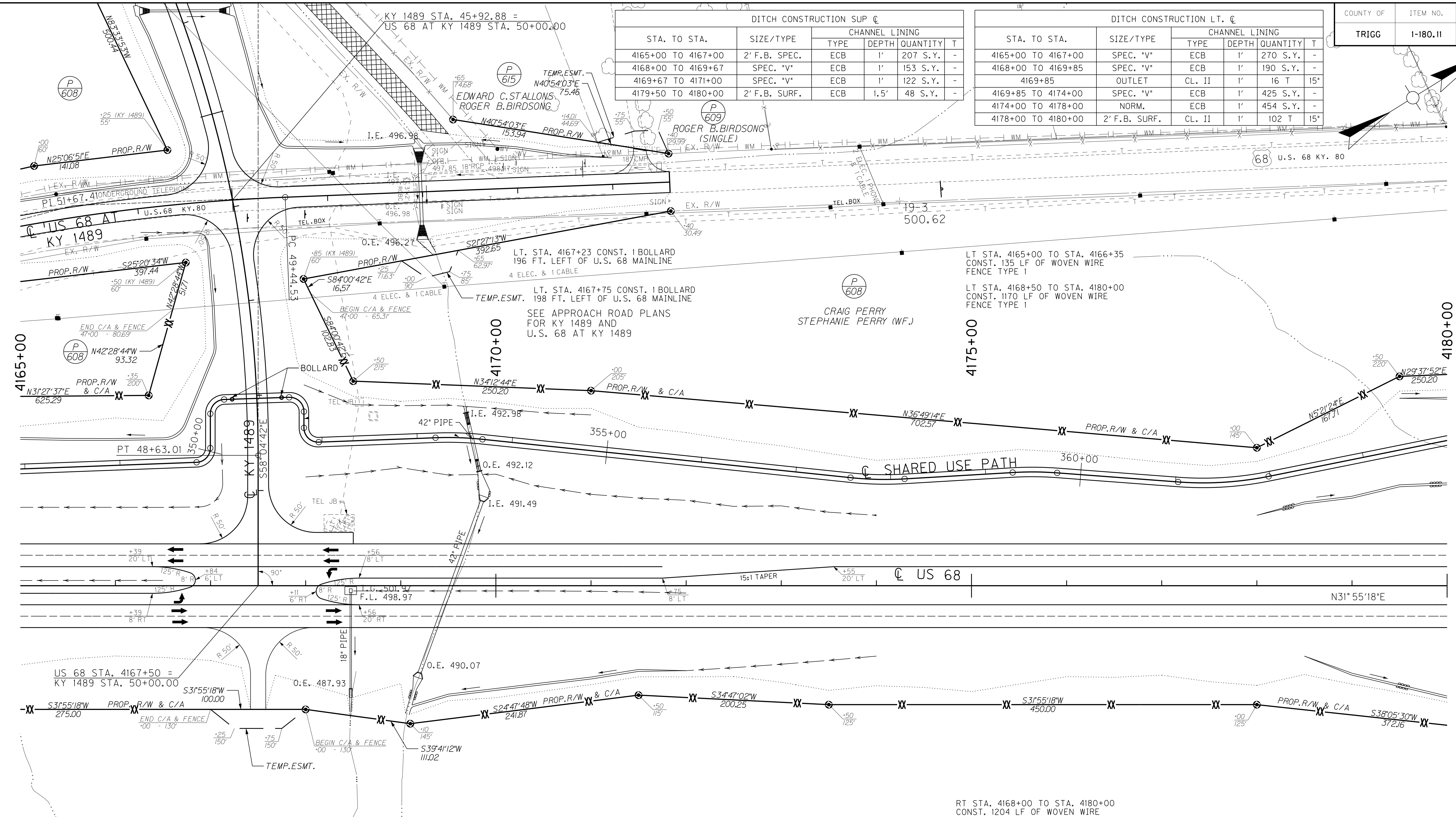

USER: \$\$\$USER\$\$\$
 DATE: \$\$\$DATE\$\$\$
 FILE NAME: \$\$\$designsfiles\$\$\$specifications\$\$\$
 E-SHEET NAME:

PREPARED BY _____ DATE _____
 CHECKED BY _____ DATE _____
 APPROVED BY _____ DATE _____

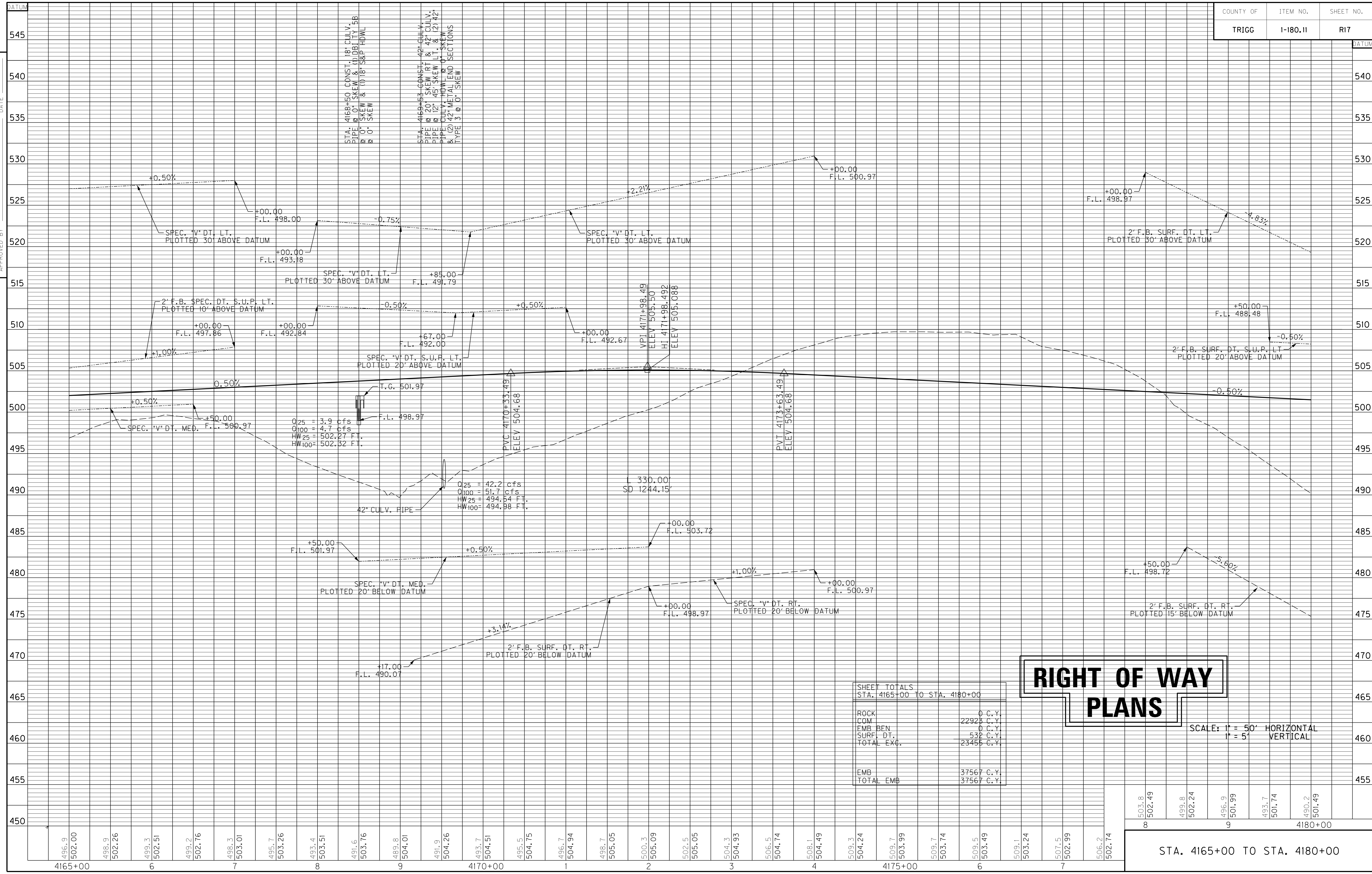

USER: \$\$\$USER\$\$\$
 DATE: \$\$\$DATE\$\$\$
 FILE NAME: \$\$\$designfiles\$\$\$
 E-SHEET NAME:

SHEET TOTALS	
STA. 4165+00 TO STA. 4180+00	
ROCK	0 C.Y.
COM.	22923 C.Y.
EMB. BEN.	0 C.Y.
SURF. DT.	532 C.Y.
TOTAL EXC.	23455 C.Y.
EMB.	37567 C.Y.
TOTAL EMB.	37567 C.Y.

**RIGHT OF WAY
PLANS**

SCALE: 1" = 50' HORIZONTAL
 1" = 5' VERTICAL

8	503.8	502.49	499.8	502.24	496.9	501.99	493.7	501.74	490.2	501.49	4180+00
---	-------	--------	-------	--------	-------	--------	-------	--------	-------	--------	---------

STA. 4165+00 TO STA. 4180+00

PREPARED BY _____ DATE _____
 CHECKED BY _____ DATE _____
 APPROVED BY _____ DATE _____

STA. TO STA.	SIZE/TYPE	CHANNEL LINING			
		TYPE	DEPTH	QUANTITY	T
4180+00 TO 4182+14	2' F.B. SURF.	ECB	1.5'	207 S.Y.	-
4182+14 TO 4184+50	2' F.B. SURF.	ECB	1'	233 S.Y.	-
4184+50 TO 4188+00	NORM.	ECB	1'	321 S.Y.	-
4188+00 TO 4190+50	SPEC. "V"	ECB	1'	229 S.Y.	-
4190+50 TO 4195+00	SPEC. "V"	ECB	1'	412 S.Y.	-

STA. TO STA.	SIZE/TYPE	CHANNEL LINING			
		TYPE	DEPTH	QUANTITY	T
4180+00 TO 4182+03	2' F.B. SURF.	CL. II	1'	91 T	15'
4182+03 TO 4184+50	OUTLET	CL. III	1'	13 T	24'
4184+50 TO 4195+00	SPEC. "V"	ECB	1'	1606 S.Y.	-

STA. TO STA.	SIZE/TYPE	CHANNEL LINING			
		TYPE	DEPTH	QUANTITY	T
4180+00 TO 4183+00	NORM.	ECB	1'	406 S.Y.	-
4183+00 TO 4185+50	SPEC. "V"	ECB	1'	382 S.Y.	-
4185+50 TO 4188+00	SPEC. "V"	ECB	1'	338 S.Y.	-
4190+00 TO 4190+50	SPEC. "V"	ECB	1'	112 S.Y.	-
4190+50 TO 4195+00	SPEC. "V"	ECB	1'	608 S.Y.	-

STA. TO STA.	SIZE/TYPE	CHANNEL LINING			
		TYPE	DEPTH	QUANTITY	T
4180+00 TO 4181+69	2' F.B. SURF.	CL. II	1'	76 T	15'
4181+69 TO 4183+00	OUTLET	CL. II	2'	35 T	15'
4183+00 TO 4183+50	2' F.B. SURF.	CL. II	1'	58 T	15'
4183+50 TO 4187+00	OUTLET	CL. II	1'	20 T	15'
4183+00 TO 4183+50	2' F.B. SPEC	CL. II	1'	22 T	15'
4183+50 TO 4187+00	SPEC. "V"	ECB	1'	324 S.Y.	-
4189+50 TO 4190+50	2' F.B. SPEC.	ECB	1'	115 S.Y.	-
4190+50 TO 4191+50	2' F.B. SPEC.	ECB	1'	115 S.Y.	-

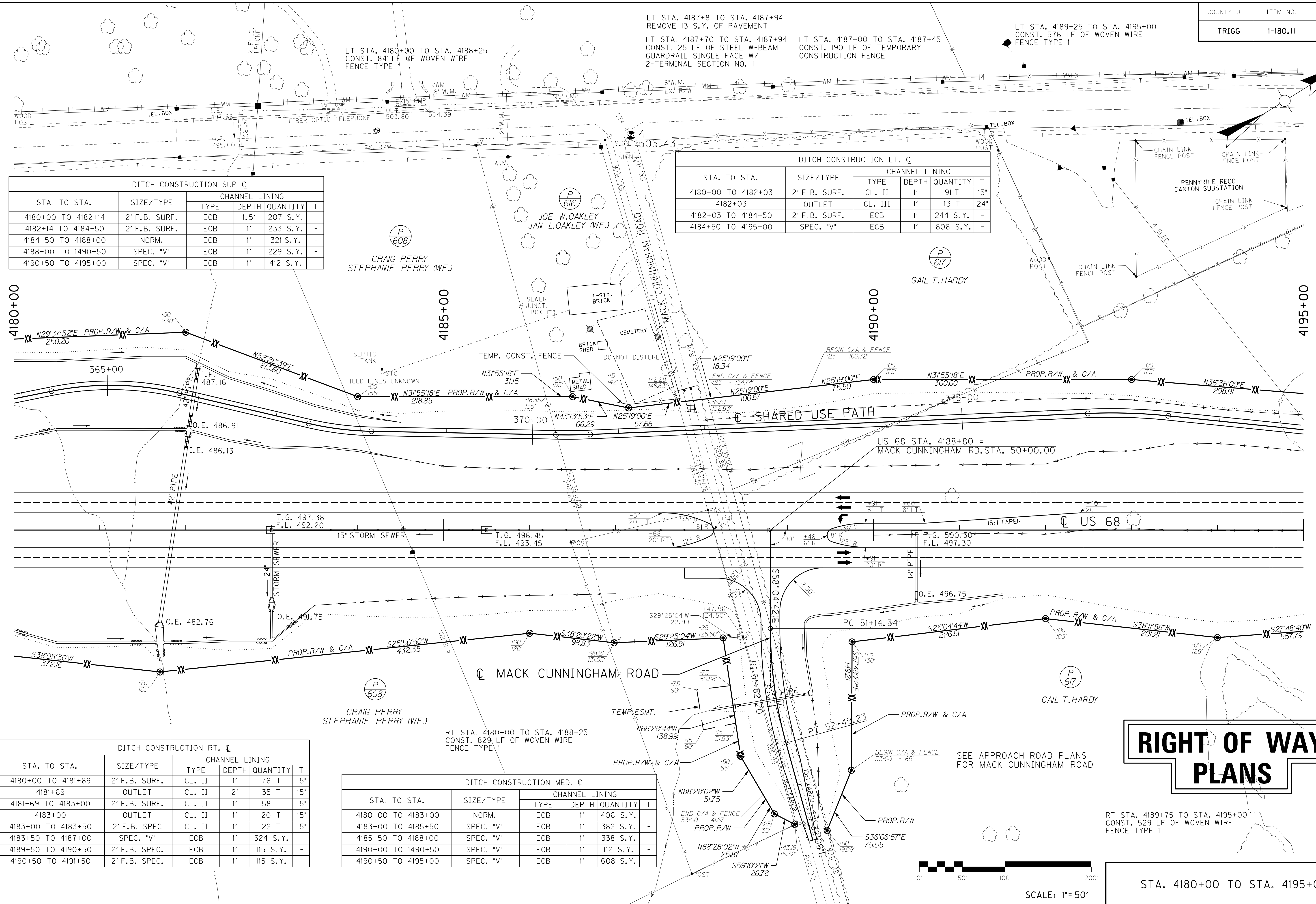

RIGHT OF WAY PLANS

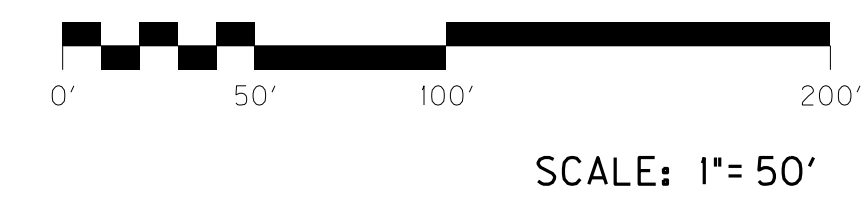

STA. 4180+00 TO STA. 4195+00

USER: \$\$\$USER\$\$\$
 DATE: \$\$\$DATE\$\$\$
 FILE NAME: \$\$\$designsfiles\$\$\$specifications\$\$\$
 E-SHEET NAME:

STA. TO STA.	SIZE/TYPE	CHANNEL LINING		
		TYPE	DEPTH	QUANTITY
4195+00 TO 4196+00	SPEC. "V"	ECB	1'	201 S.Y.
4196+00 TO 4197+50	SPEC. "V"	ECB	1'	170 S.Y.
4197+50 TO 4200+00	NORM.	ECB	1'	283 S.Y.
4200+00 TO 4201+00	SPEC. "V"	ECB	1'	103 S.Y.
4201+45 TO 4202+00	SPEC. "V"	ECB	1'	60 S.Y.
4202+00 TO 4204+00	NORM.	ECB	1'	283 S.Y.
4204+00 TO 4206+50	2' F.B. SPEC.	CL. II	1'	213 T
4206+50 TO 4210+00	2' F.B. SPEC.	ECB	1'	451 S.Y.
4206+35	2' F.B. SPEC.	CL. II	1'	12 T

STA. TO STA.	SIZE/TYPE	CHANNEL LINING		
		TYPE	DEPTH	QUANTITY
4195+00 TO 4201+06	SPEC. "V"	ECB	1'	533 S.Y.
4201+45 TO 4202+50	SPEC. "V"	ECB	1'	74 S.Y.
4202+50 TO 4204+00	NORM.	ECB	1'	121 S.Y.
4204+00 TO 4206+54	2' F.B. SPEC.	CL. II	1'	174 T
4206+54 TO 4210+00	2' F.B. SPEC.	ECB	1'	362 S.Y.

STA. TO STA.	SIZE/TYPE	CHANNEL LINING		
		TYPE	DEPTH	QUANTITY
4195+00 TO 4195+75	SPEC. "V"	ECB	1'	101 S.Y.
4195+75 TO 4198+50	SPEC. "V"	ECB	1'	372 S.Y.
4198+50 TO 4200+25	NORM.	ECB	1'	237 S.Y.
4202+00 TO 4205+50	NORM.	ECB	1'	473 S.Y.
4205+50 TO 4206+37	SPEC. "V"	ECB	1'	118 S.Y.
4206+37 TO 4207+50	SPEC. "V"	ECB	1'	153 S.Y.
4207+50 TO 4210+00	NORM.	ECB	1'	338 S.Y.

STA. TO STA.	SIZE/TYPE	CHANNEL LINING		
		TYPE	DEPTH	QUANTITY
4199+50 TO 4200+25	NORM.	ECB	1'	85 S.Y.
4200+25 TO 4200+70	NORM.	ECB	1'	46 S.Y.
4201+50 TO 4205+00	2' F.B. SPEC.	CL. II	1'	234 T
4205+00 TO 4206+00	2' F.B. SPEC.	CL. II	1'	58 T
4206+25	OUTLET	CL. II	1'	28 T
4206+26 TO 4210+00	2' F.B. SURF.	CL. II	1'	168 T

PREPARED BY _____ DATE _____
 CHECKED BY _____ DATE _____
 APPROVED BY _____ DATE _____

USER: \$\$\$USER\$\$\$
 DATE: \$\$\$DATE\$\$\$
 FILE NAME: \$\$\$designsfiles\$\$\$
 E-SHEET NAME:

RIGHT OF WAY PLANS

STA. 4195+00 TO STA. 4210+00

SCALE: 1"=50'

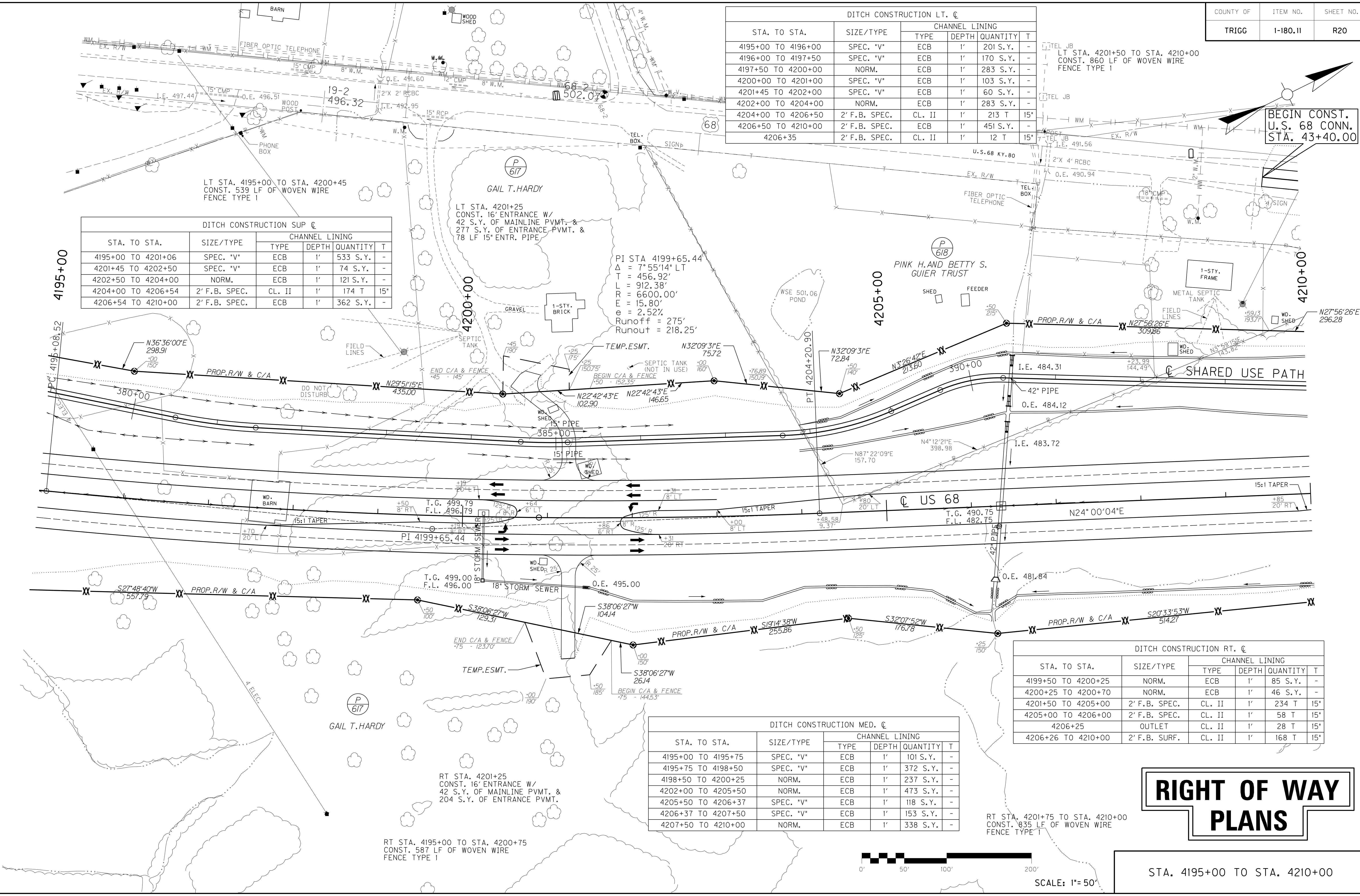
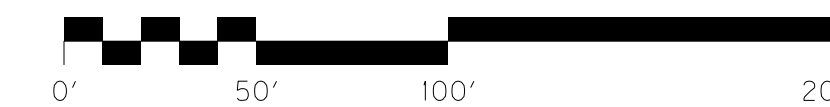

LT STA. 4195+00 TO STA. 4200+45
 CONST. 539 LF OF WOVEN WIRE
 FENCE TYPE 1

LT STA. 4201+25
 CONST. 16' ENTRANCE W/
 42 S.Y. OF MAINLINE PVMT. &
 277 S.Y. OF ENTRANCE PVMT. &
 78 LF 15' ENTR. PIPE

PI STA. 4199+65.44
 $\Delta = 7^{\circ}55'14''$ LT
 $T = 456.92'$
 $L = 912.38'$
 $R = 6600.00'$
 $E = 15.80'$
 $e = 2.52\%$
 Runoff = 275'
 Runout = 218.25'

LT STA. 4201+50 TO STA. 4210+00
 CONST. 860 LF OF WOVEN WIRE
 FENCE TYPE 1

BEGIN CONST.
 U.S. 68 CONN.
 STA. 43+40.00

RT STA. 4195+00 TO STA. 4200+75
 CONST. 587 LF OF WOVEN WIRE
 FENCE TYPE 1

RT STA. 4201+75 TO STA. 4210+00
 CONST. 835 LF OF WOVEN WIRE
 FENCE TYPE 1

PREPARED BY _____ DATE _____
 CHECKED BY _____ DATE _____
 APPROVED BY _____ DATE _____

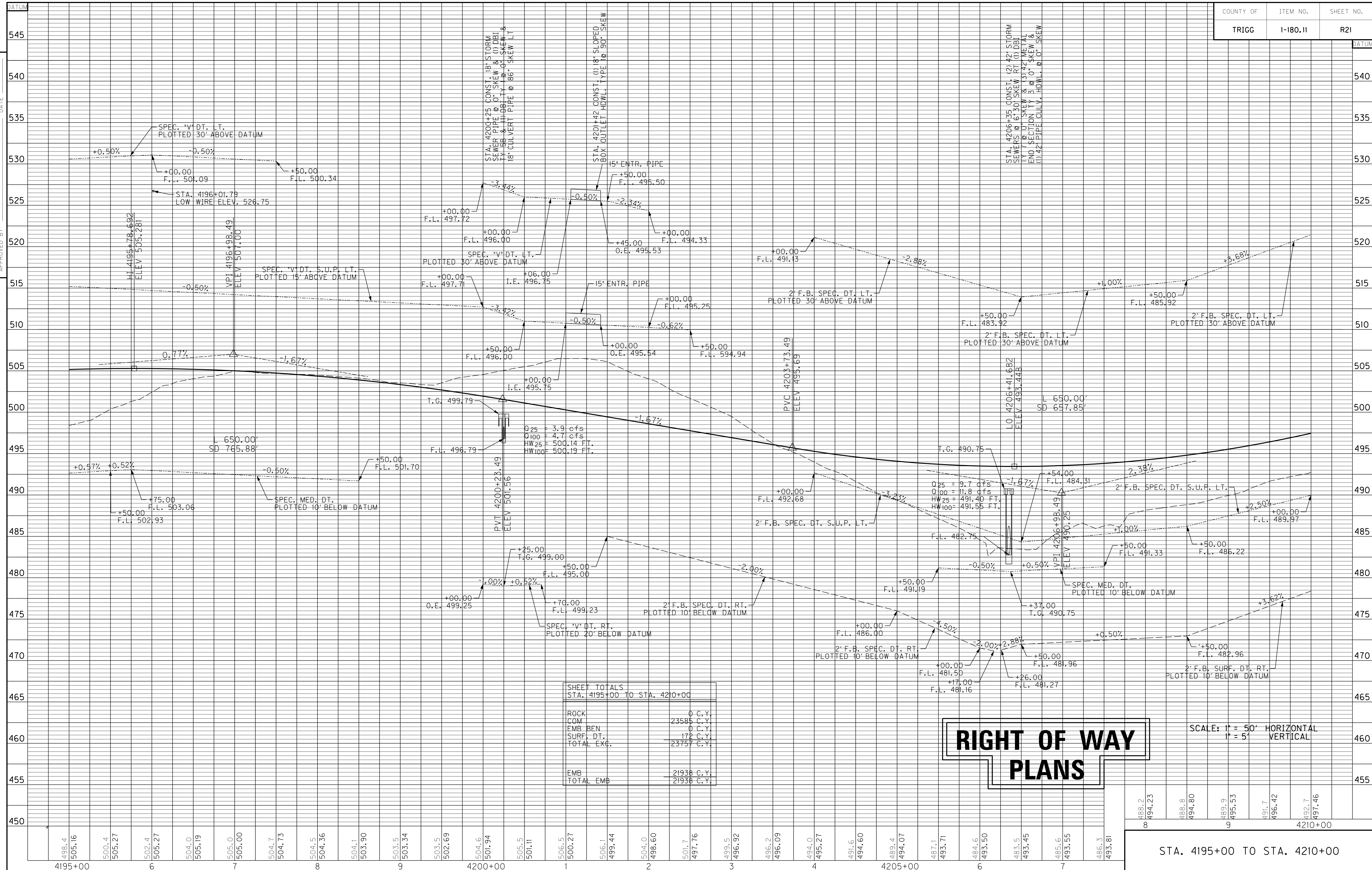

SHEET TOTALS	
STA. 4195+00 TO STA. 4210+00	
ROCK	0 C.Y.
COM.	23585 C.Y.
EMB. BEN.	0 C.Y.
SURF. DT.	172 C.Y.
TOTAL EXC.	23757 C.Y.
EMB.	21938 C.Y.
TOTAL EMB.	21938 C.Y.

**RIGHT OF WAY
PLANS**

SCALE: 1" = 50' HORIZONTAL
1" = 5' VERTICAL

USER: \$\$\$USER\$\$\$
 DATE: \$\$\$DATE\$\$\$
 FILE NAME: \$\$\$designfiles\$\$\$
 E-SHEET NAME:

STA. 4195+00 TO STA. 4210+00

US 68 CONN. DITCH CONSTRUCTION LT. C					
STA. TO STA.	SIZE/TYPE	CHANNEL LINING			
		TYPE	DEPTH	QUANTITY	T
45+00 TO 48+25	SPEC. "V"	ECB	1'	300 S.Y.	-
48+50 TO 49+00	NORM.	ECB	1'	46 S.Y.	-

DITCH CONSTRUCTION SUP LT. C (MAINLINE)					
STA. TO STA.	SIZE/TYPE	CHANNEL LINING			
		TYPE	DEPTH	QUANTITY	T
4210+00 TO 4213+00	2' F.B. SPEC.	ECB	1'	279 S.Y.	-
4213+80 TO 4215+50	SPEC. "V"	ECB	1'	92 S.Y.	-

DITCH CONSTRUCTION SUP LT. C					
STA. TO STA.	SIZE/TYPE	CHANNEL LINING			
		TYPE	DEPTH	QUANTITY	T
401+00 TO 404+00	SPEC. "V"	ECB	1'	274 S.Y.	-

DITCH CONSTRUCTION LT. C					
STA. TO STA.	SIZE/TYPE	CHANNEL LINING			
		TYPE	DEPTH	QUANTITY	T
4210+00 TO 4213+05	2' F.B. SPEC.	ECB	1'	472 S.Y.	-
4213+76 TO 4216+00	SPEC. "V"	ECB	1'	275 S.Y.	-
4216+00 TO 4217+50	2' F.B. SPEC.	ECB	1'	118 S.Y.	-
4217+50 TO 4218+95	2' F.B. SURF.	ECB	1'	114 S.Y.	-
4218+95 TO 4222+50	2' F.B. SURF.	ECB	1'	252 S.Y.	-
4222+50 TO 4225+00	SPEC. "V"	ECB	1'	283 S.Y.	-

US 68 CONN. DITCH CONSTRUCTION RT. C					
STA. TO STA.	SIZE/TYPE	CHANNEL LINING			
		TYPE	DEPTH	QUANTITY	T
43+40 TO 45+50	NORM.	ECB	1'	138 S.Y.	-
45+50 TO 47+50	SPEC. "V"	ECB	1'	231 S.Y.	-
47+50 TO 48+13	SPEC. "V"	ECB	1'	58 S.Y.	-
48+50 TO 49+18	SPEC. "V"	ECB	1'	63 S.Y.	-

DITCH CONSTRUCTION SUP RT. C					
STA. TO STA.	SIZE/TYPE	CHANNEL LINING			
		TYPE	DEPTH	QUANTITY	T
401+00 TO 404+00	SPEC. "V"	ECB	1'	274 S.Y.	-

PREPARED BY _____ DATE _____
 CHECKED BY _____ DATE _____
 APPROVED BY _____ DATE _____

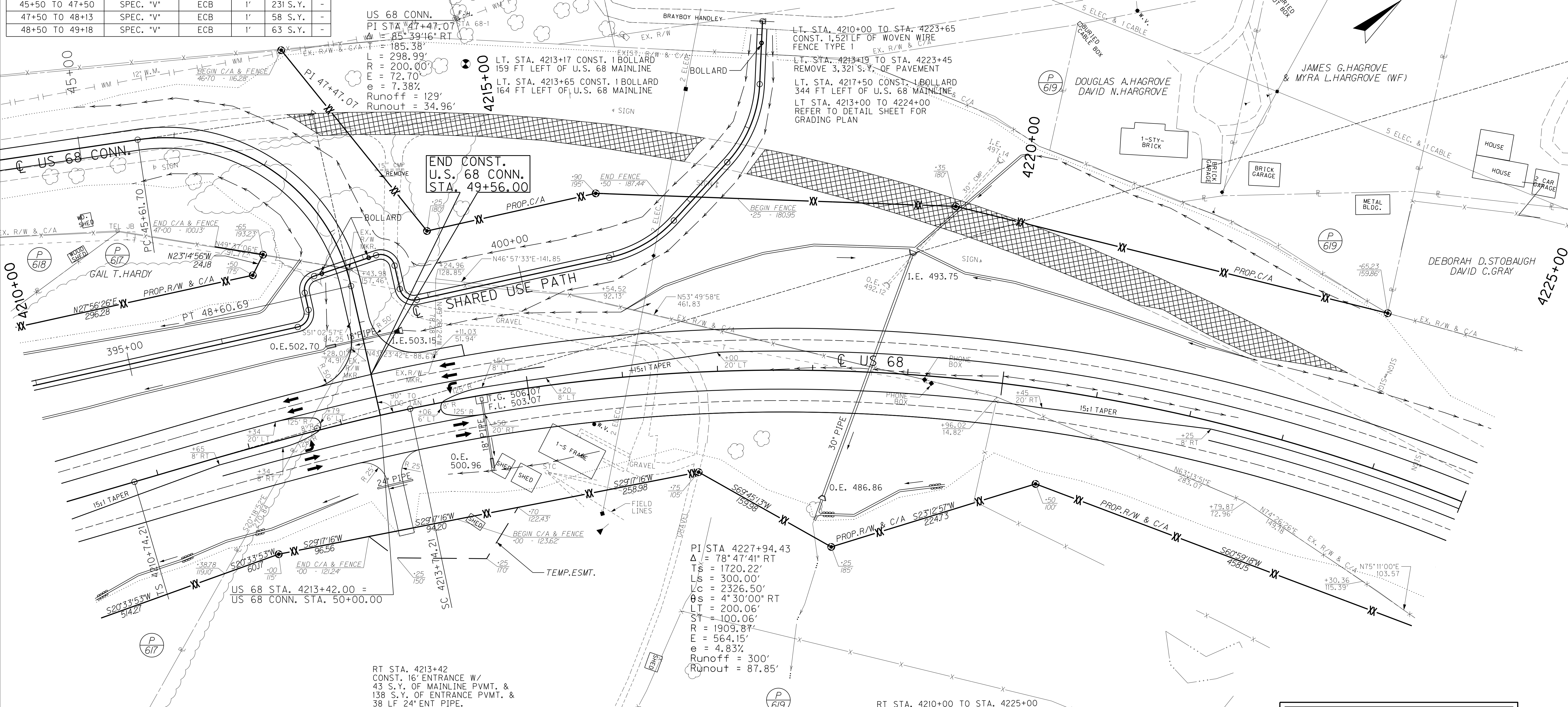

DITCH CONSTRUCTION RT. C					
STA. TO STA.	SIZE/TYPE	CHANNEL LINING			
		TYPE	DEPTH	QUANTITY	T
4210+00 TO 4212+00	2' F.B. SURF.	CL. II	1'	90 T	15'
4212+00 TO 4213+20	2' F.B. SPEC.	ECB	1'	163 S.Y.	-
4213+60 TO 4214+50	SPEC. "V"	ECB	1'	102 S.Y.	-
4214+50 TO 4215+50	SPEC. "V"	ECB	1'	113 S.Y.	-
4215+50 TO 4217+00	NORM.	ECB	1'	170 S.Y.	-
4218+11	OUTLET	CL. II	1.5'	14 T	15'
4218+11 TO 4219+50	2' F.B. SURF.	CL. II	1'	63 T	15'
4220+50 TO 4225+00	NORM.	ECB	1'	510 S.Y.	-

DITCH CONSTRUCTION MED. C					
STA. TO STA.	SIZE/TYPE	CHANNEL LINING			
		TYPE	DEPTH	QUANTITY	T
4210+00 TO 4212+50	NORM.	ECB	1'	338 S.Y.	-
4214+50 TO 4217+50	NORM.	ECB	1'	406 S.Y.	-
4217+50 TO 4220+50	SPEC. "V"	ECB	1'	406 S.Y.	-
4220+50 TO 4222+50	SPEC. "V"	ECB	1'	425 S.Y.	-
4222+50 TO 4225+00	NORM.	ECB	1'	338 S.Y.	-

RIGHT OF WAY PLANS

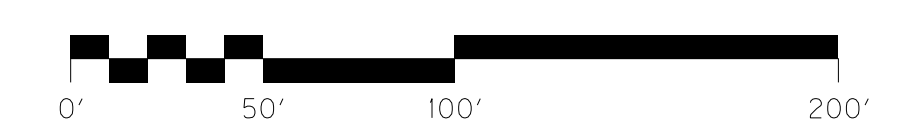

SCALE: 1" = 50'

STA. 4210+00 TO STA. 4225+00

USER: \$\$\$USER\$\$\$
 DATE: \$\$\$DATE\$\$\$
 FILE NAME: \$\$\$designsfilespecifications\$\$\$
 E-SHEET NAME:

PREPARED BY _____ DATE _____
 CHECKED BY _____ DATE _____
 APPROVED BY _____ DATE _____

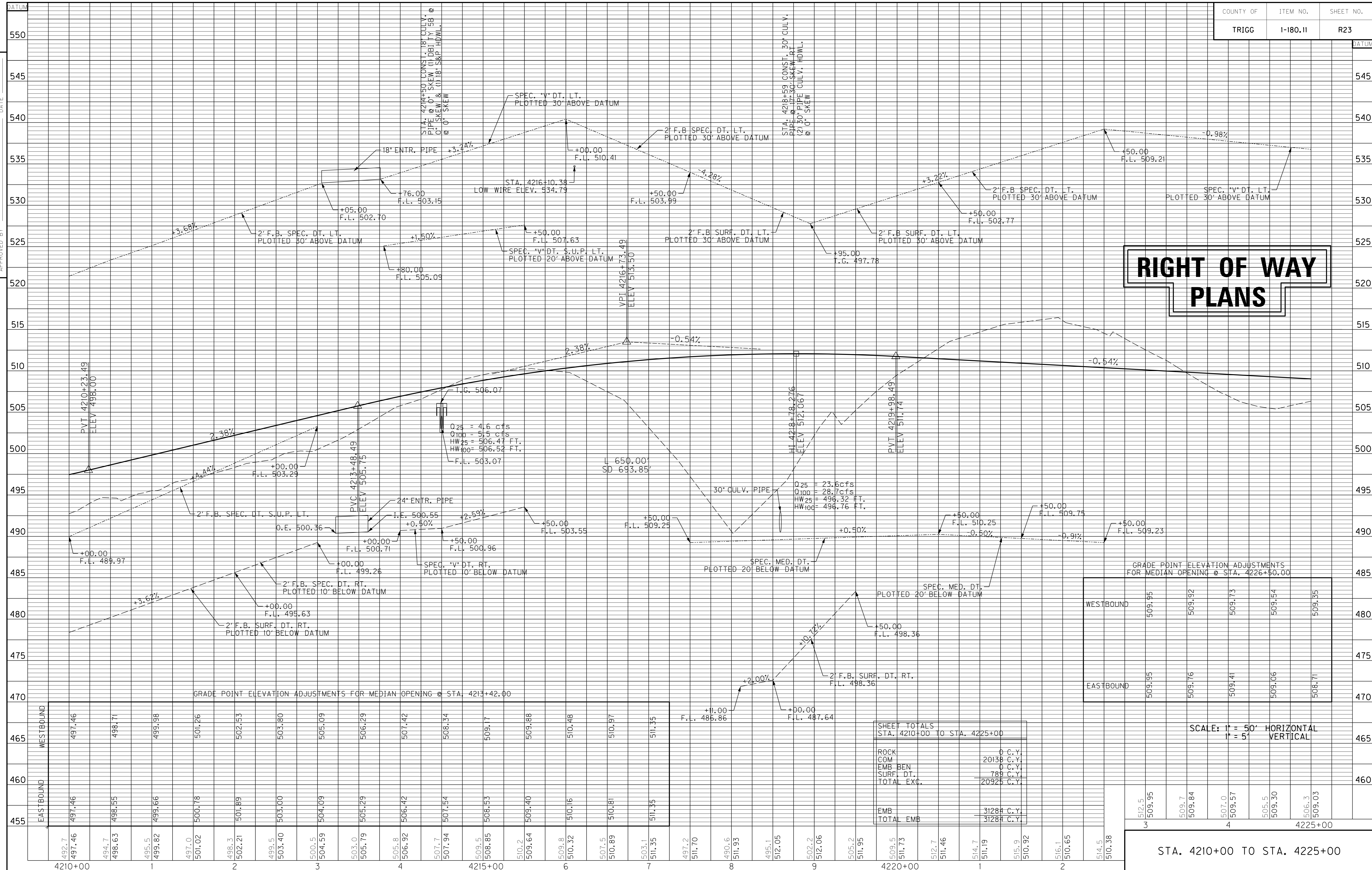

RIGHT OF WAY PLANS

GRADE POINT ELEVATION ADJUSTMENTS FOR MEDIAN OPENING @ STA. 4213+42.00

GRADE POINT ELEVATION ADJUSTMENTS FOR MEDIAN OPENING @ STA. 4226+50.00

SHEET TOTALS STA. 4210+00 TO STA. 4225+00	
ROCK	0 C.Y.
COM	20138 C.Y.
EMB BEN	0 C.Y.
SURF. DT.	789 C.Y.
TOTAL EXC.	20925 C.Y.
EMB	31284 C.Y.
TOTAL EMB	31284 C.Y.

SCALE: 1" = 50' HORIZONTAL
 1" = 5' VERTICAL

STA. 4210+00 TO STA. 4225+00

USER: \$\$\$USER\$\$\$
 DATE: \$\$\$DATE\$\$\$
 FILE NAME: \$\$\$designfiles\$\$\$
 E-SHEET NAME:

STATION	EASTBOUND	WESTBOUND
4210+00	492.7	497.46
	497.46	497.46
	494.7	498.55
	498.63	498.71
	495.5	499.66
	499.82	499.98
	497.0	501.26
	501.02	500.78
	498.3	501.89
	502.21	502.53
	499.5	503.80
	503.40	503.00
	500.5	504.09
	504.59	505.09
	503.0	505.29
	505.79	506.29
	505.8	506.42
	506.92	506.42
	507.7	507.54
	507.94	508.34
	509.5	509.17
	508.85	508.53
	510.2	509.40
	509.64	509.88
	510.32	510.48
	507.5	510.81
	510.89	510.97
	503.1	511.35
	511.35	511.35
	497.2	
	511.70	
	490.6	
	511.93	
	495.1	
	512.05	
	502.2	
	512.06	
	505.2	
	511.95	
	509.5	
	511.73	
	512.7	
	511.46	
	514.7	
	511.19	
	515.9	
	510.92	
	516.1	
	510.65	
	514.5	
	510.38	

STATION	EASTBOUND	WESTBOUND
3	509.95	509.95
	509.7	509.92
	509.84	509.73
	507.0	509.54
	509.57	509.35
	505.5	509.06
	509.30	508.71
	506.3	
	509.03	
4	4225+00	

PREPARED BY _____ DATE _____
 CHECKED BY _____ DATE _____
 APPROVED BY _____ DATE _____

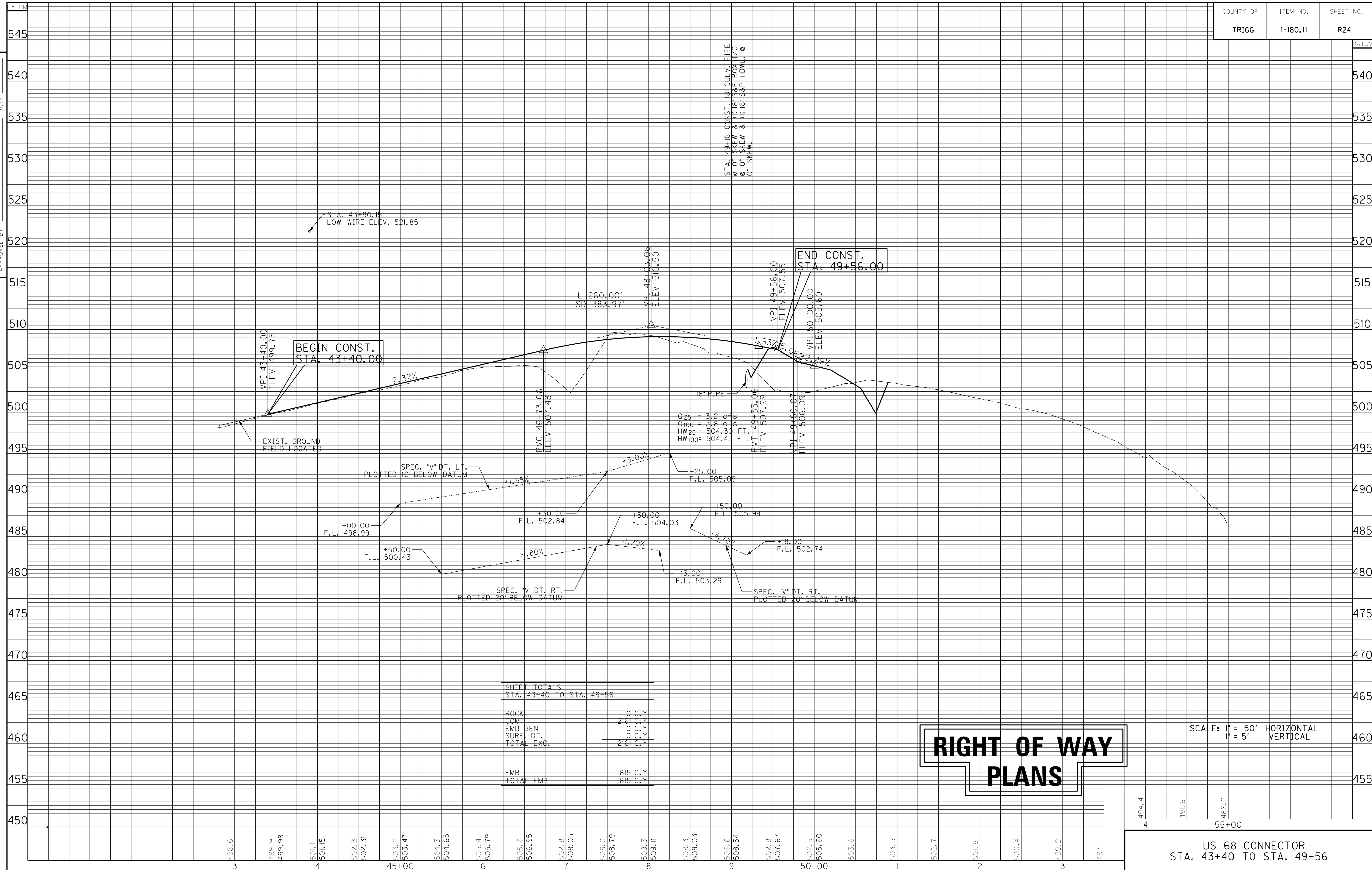

USER: \$\$\$USER\$\$\$
 DATE: \$\$\$DATE\$\$\$
 FILE NAME: \$\$\$designsfilespecifications\$\$\$
 E-SHEET NAME:

SHEET TOTALS	
STA. 43+40 TO STA. 49+56	
ROCK	0 C.Y.
COM.	2161 C.Y.
EMB. BEN	0 C.Y.
SURF. DT.	0 C.Y.
TOTAL EXC.	2161 C.Y.
EMB	615 C.Y.
TOTAL EMB	615 C.Y.

**RIGHT OF WAY
PLANS**

SCALE: 1" = 50' HORIZONTAL
1" = 5' VERTICAL

494.4	491.6	486.2	55+00
4			
US 68 CONNECTOR STA. 43+40 TO STA. 49+56			

PREPARED BY _____ DATE _____
 CHECKED BY _____ DATE _____
 APPROVED BY _____ DATE _____

STA. TO STA.	SIZE/TYPE	CHANNEL LINING			
		TYPE	DEPTH	QUANTITY	T
4225+00 TO 4225+90	SPEC. "V"	ECB	1'	113 S.Y.	-
4226+96 TO 4229+00	2' F.B. SPEC.	ECB	1'	212 S.Y.	-
4229+00 TO 4232+50	SPEC. "V"	ECB	1'	454 S.Y.	-

STA. TO STA.	SIZE/TYPE	CHANNEL LINING			
		TYPE	DEPTH	QUANTITY	T
4225+00 TO 4225+50	NORM.	ECB	1'	68 S.Y.	-
4227+50 TO 4229+00	NORM.	ECB	1'	203 S.Y.	-
4229+00 TO 4234+50	NORM.	ECB	1'	732 S.Y.	-
4234+50 TO 4238+00	NORM.	ECB	1'	397 S.Y.	-

RIGHT OF WAY PLANS

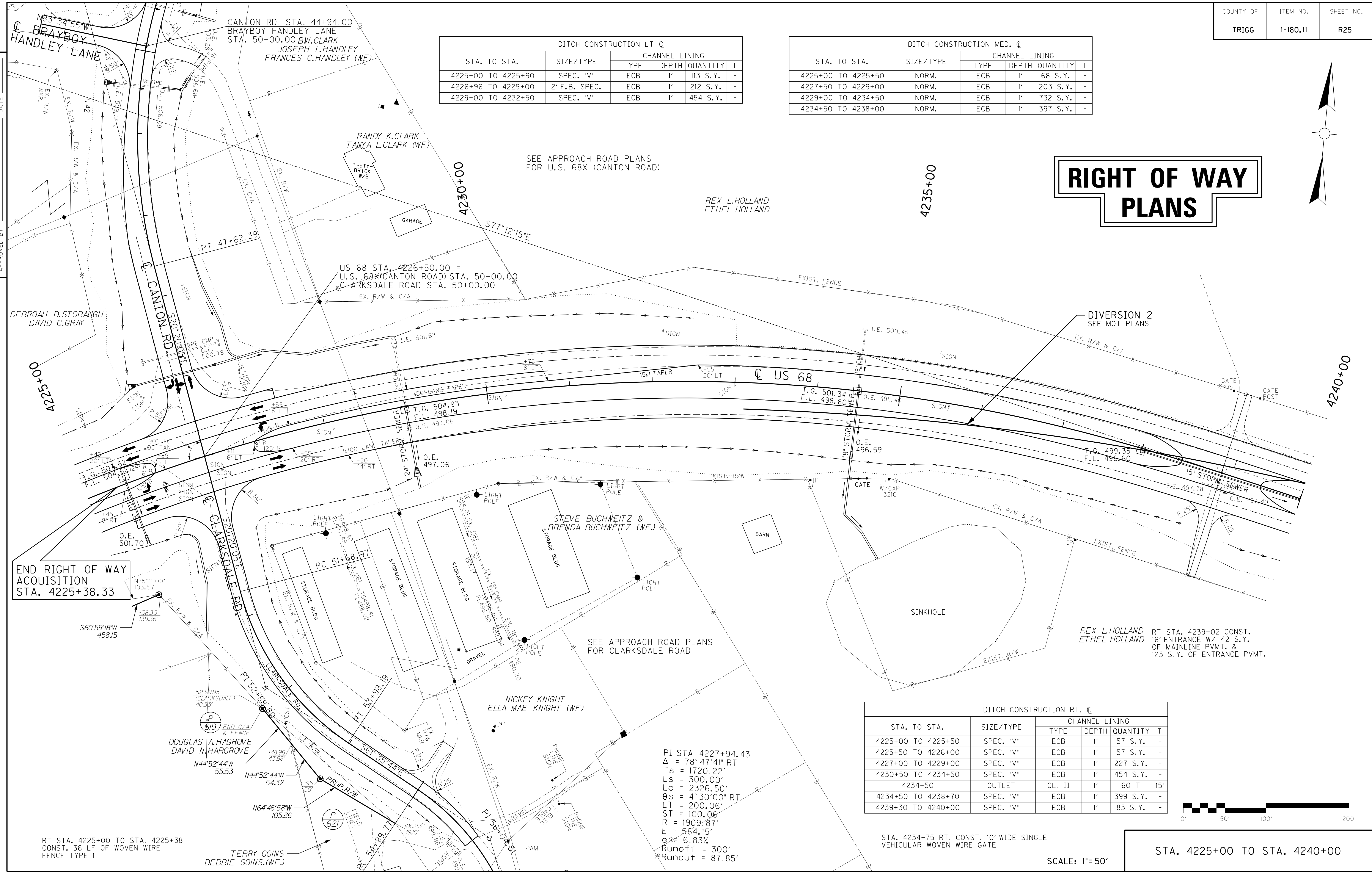
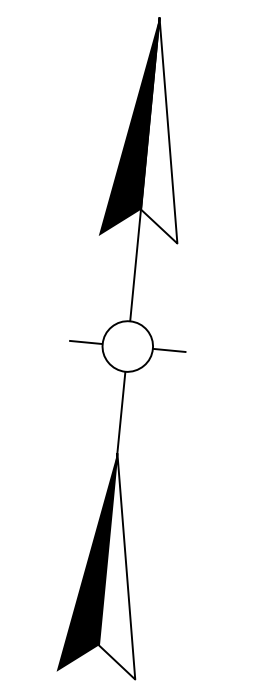

END RIGHT OF WAY ACQUISITION STA. 4225+38.33

SEE APPROACH ROAD PLANS FOR CLARKSDALE ROAD

REX L. HOLLAND
 ETHEL HOLLAND
 RT STA. 4239+02 CONST.
 16' ENTRANCE W/ 42 S.Y.
 OF MAINLINE PVMT. &
 123 S.Y. OF ENTRANCE PVMT.

STA. TO STA.	SIZE/TYPE	CHANNEL LINING			
		TYPE	DEPTH	QUANTITY	T
4225+00 TO 4225+50	SPEC. "V"	ECB	1'	57 S.Y.	-
4225+50 TO 4226+00	SPEC. "V"	ECB	1'	57 S.Y.	-
4227+00 TO 4229+00	SPEC. "V"	ECB	1'	227 S.Y.	-
4230+50 TO 4234+50	SPEC. "V"	ECB	1'	454 S.Y.	-
4234+50	OUTLET	CL. II	1'	60 T	15'
4234+50 TO 4238+70	SPEC. "V"	ECB	1'	399 S.Y.	-
4239+30 TO 4240+00	SPEC. "V"	ECB	1'	83 S.Y.	-

PI STA 4227+94.43
 $\Delta = 78^\circ 47' 41''$ RT
 $T_s = 1720.22'$
 $L_s = 300.00'$
 $L_c = 2326.50'$
 $\theta_s = 4^\circ 30' 00''$ RT
 $LT = 200.06'$
 $ST = 100.06'$
 $R = 1909.87'$
 $E = 564.15'$
 $e = 6.83\%$
 $Runoff = 300'$
 $Runout = 87.85'$

STA. 4234+75 RT. CONST. 10' WIDE SINGLE VEHICULAR WOVEN WIRE GATE

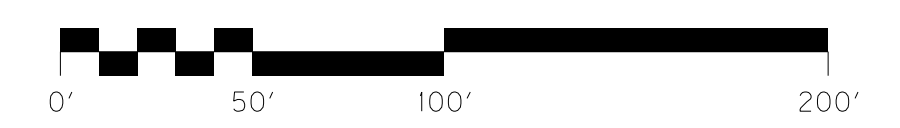

SCALE: 1"=50'

STA. 4225+00 TO STA. 4240+00

USER: \$\$\$USER\$\$\$
 DATE: \$\$\$DATE\$\$\$
 FILE NAME: \$\$\$designsfilespecifications\$\$\$
 E-SHEET NAME:

RT STA. 4225+00 TO STA. 4225+38
 CONST. 36 LF OF WOVEN WIRE FENCE TYPE 1

PREPARED BY _____ DATE _____
 CHECKED BY _____ DATE _____
 APPROVED BY _____ DATE _____

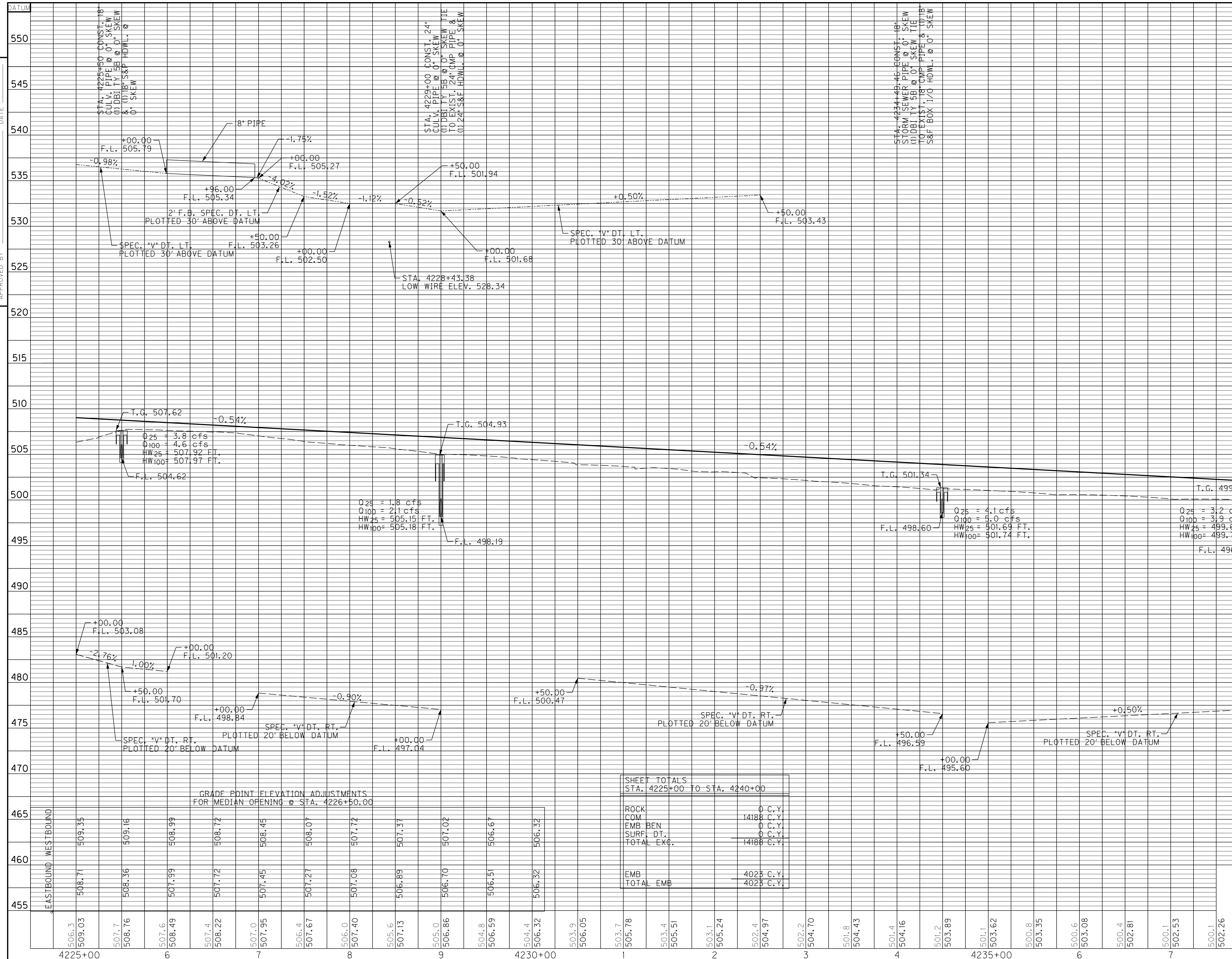

RIGHT OF WAY PLANS

USER: \$\$\$USER\$\$\$
 DATE: \$\$\$DATE\$\$\$
 FILE NAME: \$\$\$designfiles\$\$\$specifications\$\$\$
 E-SHEET NAME:

GRADE POINT ELEVATION ADJUSTMENTS
FOR MEDIAN OPENING @ STA. 4226+50.00

SHEET TOTALS STA. 4225+00 TO STA. 4240+00	
ROCK	0 C.Y.
COM	14188 C.Y.
EMB. BEN	0 C.Y.
SURF. DT.	0 C.Y.
TOTAL EXC.	14188 C.Y.
EMB	4025 C.Y.
TOTAL EMB	4025 C.Y.

SCALE: 1" = 50' HORIZONTAL
1" = 5' VERTICAL

STA. 4225+00 TO STA. 4240+00

500.0	501.99	500.1	501.72	500.0	501.45	499.6	501.18	499.2	500.91
8		9							4240+00

STA. TO STA.	SIZE/TYPE	CHANNEL LINING			
		TYPE	DEPTH	QUANTITY	T
4240+00 TO 4240+50	NORM.	ECB	1'	57 S.Y.	-
4240+50 TO 4241+00	SPEC. "V"	ECB	1'	57 S.Y.	-
4241+00 TO 4246+50	NORM.	ECB	1'	733 S.Y.	-
4246+50 TO 4247+00	NORM.	ECB	1'	57 S.Y.	-

PI STA 4248+36.19
 $\Delta = 4^{\circ}26'45" \text{ LT}$
 $T = 222.41'$
 $L = 444.59'$
 $E = 5729.58'$
 $e = 4.31'$
 $\epsilon = 2.84\%$
 Runoff = 175'
 Runout = 123.24'

LT. STA. 4253+12
 CONST. 35 LF EDGE KEY

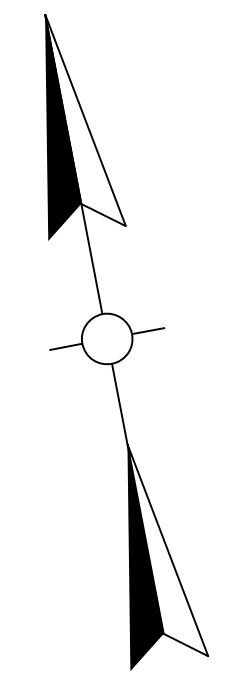

PREPARED BY _____ DATE _____
 CHECKED BY _____ DATE _____
 APPROVED BY _____ DATE _____

4240+00

4245+00

4250+00

4255+00

BEGIN TEMP. TIE
 STA. 4240+20.00

DIVERION 2
 SEE MOT PLANS

END PROJECT
 STA. 4252+00.00

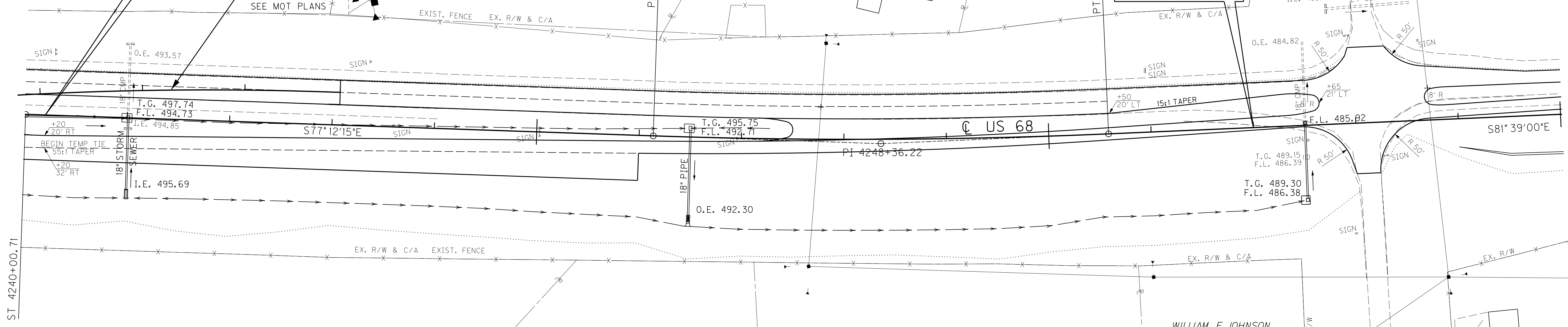

SEE DETAIL SHEETS
 FOR TEMPORARY TIE-IN

STA. TO STA.	SIZE/TYPE	CHANNEL LINING			
		TYPE	DEPTH	QUANTITY	T
4240+00 TO 4241+00	SPEC. "V"	ECB	1'	113 S.Y.	-
4241+00 TO 4241+50	SPEC. "V"	ECB	1'	57 S.Y.	-
4241+50 TO 4246+50	SPEC. "V"	ECB	1'	462 S.Y.	-
4246+50 TO 4252+50	SPEC. "V"	ECB	1'	559 S.Y.	-
4254+00 TO 4255+00	2' F.B. SPEC.	ECB	1'	114 S.Y.	-

RIGHT OF WAY PLANS

LT. STA. 4253+12
 CONST. 24 LF EDGE KEY

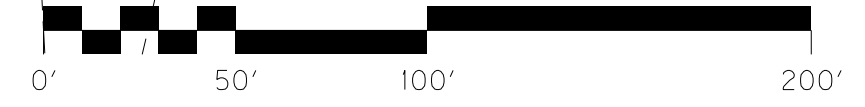

SCALE: 1"= 50'

STA. 4240+00 TO STA. 4255+00

USER: \$\$\$USER\$\$\$
 DATE: \$\$\$DATE\$\$\$
 FILE NAME: \$\$\$designsfiles\$\$\$specifications\$\$\$
 E-SHEET NAME:

PREPARED BY _____ DATE _____
 CHECKED BY _____ DATE _____
 APPROVED BY _____ DATE _____

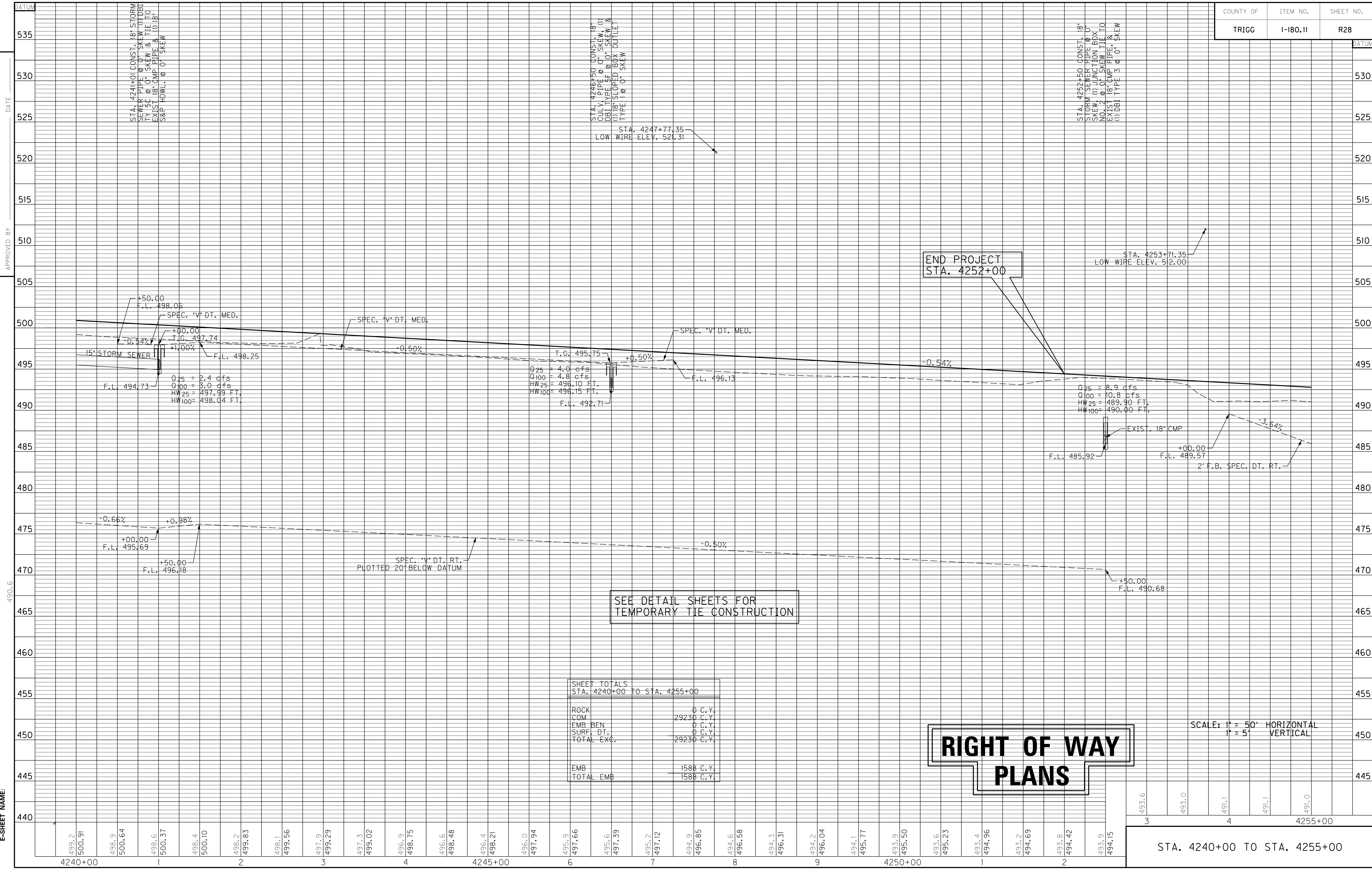

SHEET TOTALS	
STA. 4240+00 TO STA. 4255+00	
ROCK	0 C.Y.
COM.	29230 C.Y.
EMB. BEN.	0 C.Y.
SURF. DT.	0 C.Y.
TOTAL EXC.	29230 C.Y.
EMB.	1588 C.Y.
TOTAL EMB.	1588 C.Y.

**RIGHT OF WAY
PLANS**

SCALE: 1" = 50' HORIZONTAL
1" = 5' VERTICAL

STA. 4240+00 TO STA. 4255+00

USER: \$\$\$USER\$\$\$
 DATE: \$\$\$DATE\$\$\$
 FILE NAME: \$\$\$designfiles\$\$\$
 E-SHEET NAME:

490.6

493.6
 493.0
 491.1
 491.1
 491.0
 4255+00

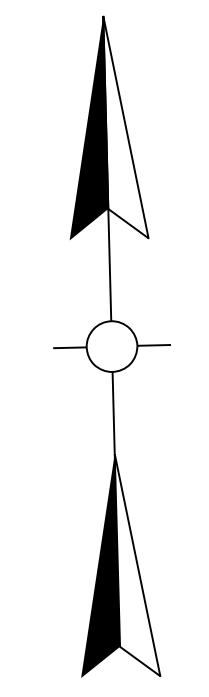

STA. 4260+83 CONST. 24
LF EDGE KEY

PI STA 4264+95.00
 $\Delta = 20^{\circ}03'11''$ LT
 Ts = 635.61'
 Ls = 250.00'
 Lc = 760.48'
 $\theta s = 2^{\circ}28'00''$ LT
 LT = 166.68'
 ST = 83.35'
 R = 2887.13'
 E = 45.69'
 e = 5.16%
 Runoff = 250'
 Runout = 96.40'

PREPARED BY _____ DATE _____
 CHECKED BY _____ DATE _____
 APPROVED BY _____ DATE _____

MARK LANE
 ERA LANE (DECEASED)
 LOUISE LANE (WF)
 L.L. WADLINGTON
 MARY LOUISE
 WADLINGTON (WF)

EDGAR L. BRIDGES
 MARIE BRIDGES (WF)

END TEMP. TIE CONST
 STA. 4260+83.43

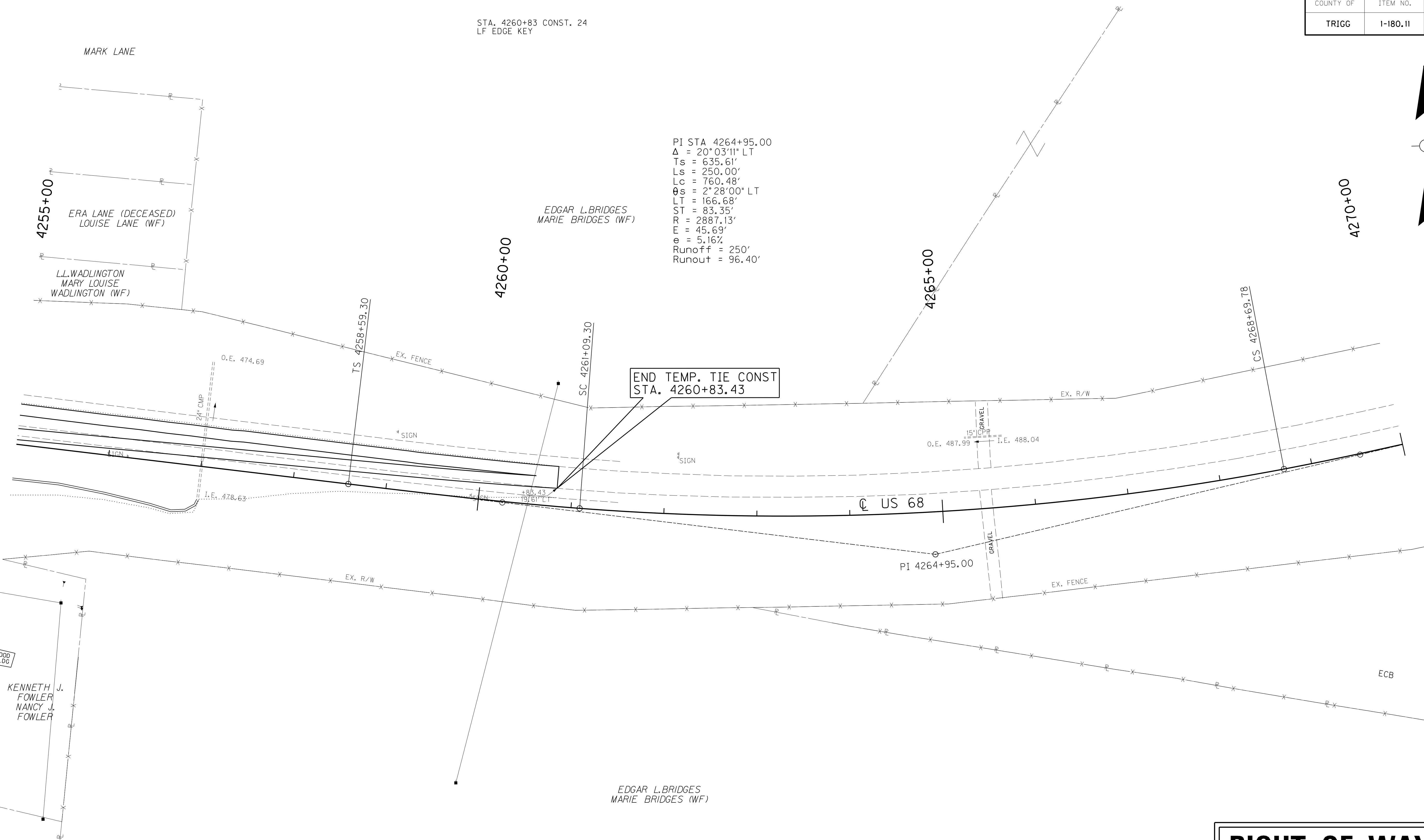

WOOD BLDG
 KENNETH J. FOWLER
 NANCY J. FOWLER

EDGAR L. BRIDGES
 MARIE BRIDGES (WF)

RIGHT OF WAY PLANS

STA. TO STA.	SIZE/TYPE	DITCH CONSTRUCTION RT. @			
		CHANNEL LINING			
		TYPE	DEPTH	QUANTITY	T
4255+00 TO 4257+00	2' F.B. SPEC.	ECB	1'	228 S.Y.	-



STA. 4255+00 TO STA. 4270+00

USER: \$\$\$USER\$\$\$
 DATE: \$\$\$DATE\$\$\$
 FILE NAME: \$\$\$designsfiles\$specifications\$\$\$
 E-SHEET NAME:

PREPARED BY _____ DATE _____
 CHECKED BY _____ DATE _____
 APPROVED BY _____ DATE _____

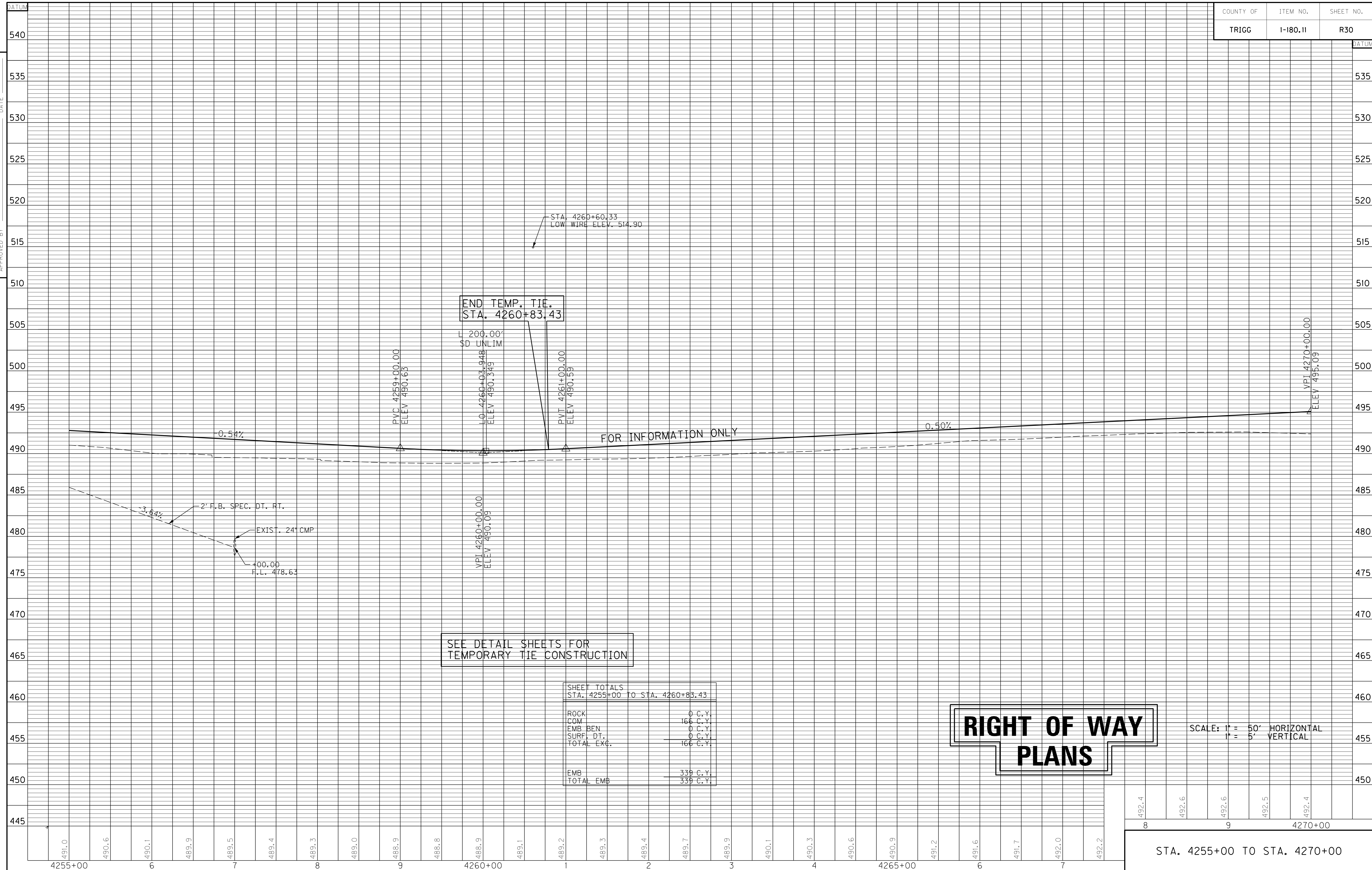

SEE DETAIL SHEETS FOR
TEMPORARY TIE CONSTRUCTION

SHEET TOTALS	
STA. 4255+00 TO STA. 4260+83.43	
ROCK	0 C.Y.
COM	166 C.Y.
EMB BEN	0 C.Y.
SURF. DT.	0 C.Y.
TOTAL EXC.	166 C.Y.
EMB	339 C.Y.
TOTAL EMB	339 C.Y.

**RIGHT OF WAY
PLANS**

SCALE: 1" = 50' HORIZONTAL
1" = 5' VERTICAL

STA. 4255+00 TO STA. 4270+00

USER: \$\$\$USER\$\$\$
 DATE: \$\$\$DATE\$\$\$
 FILE NAME: \$\$\$designsfilespecifications\$\$\$
 E-SHEET NAME:

RIGHT OF WAY PLANS

DITCH CONSTRUCTION LT @						
STA. TO STA.	SIZE/TYPE	CHANNEL LINING				
		TYPE	DEPTH	QUANTITY	T	
51+00 TO 52+00	SPEC. "V"	ECB	1'	92 S.Y.	-	
52+00 TO 54+60	2' F.B. SURF.	ECB	1'	208 S.Y.	-	
54+62	OUTLET	CL. II	1'	19 T	15"	
54+65 TO 57+50	2' F.B. SURF.	ECB	1'	209 S.Y.	-	

PREPARED BY _____ DATE _____
 CHECKED BY _____ DATE _____
 APPROVED BY _____ DATE _____

US 68 STA. 5177+49.11 =
 AVERITT LUMBER RD. STA. 50+00.00 =
 FRONTAGE ROAD NO. 1 STA. 10+00.00

END CONST.
 STA. 57+84.89

BEGIN CONST.
 STA. 50+44.00

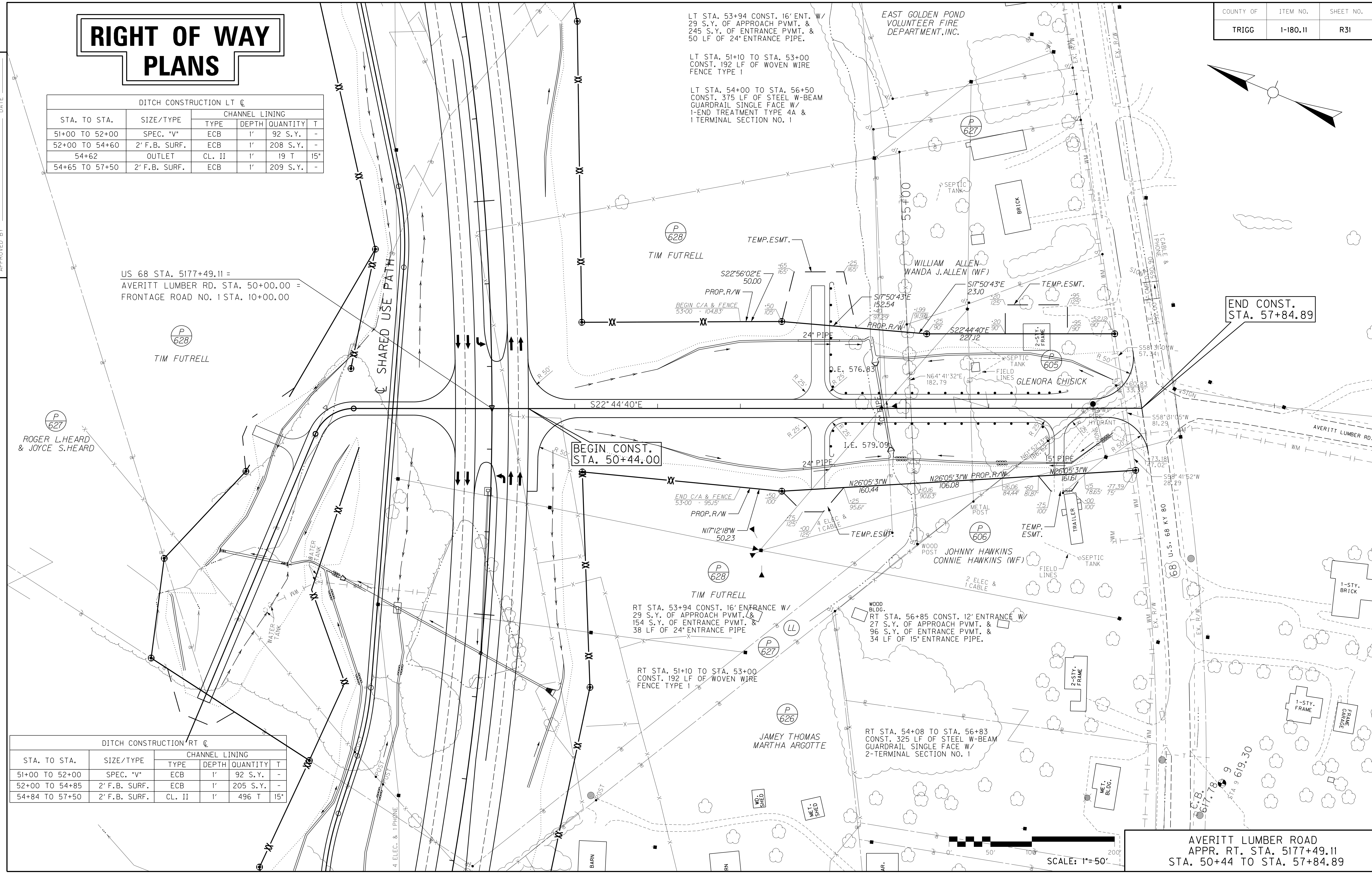

DITCH CONSTRUCTION RT @						
STA. TO STA.	SIZE/TYPE	CHANNEL LINING				
		TYPE	DEPTH	QUANTITY	T	
51+00 TO 52+00	SPEC. "V"	ECB	1'	92 S.Y.	-	
52+00 TO 54+85	2' F.B. SURF.	ECB	1'	205 S.Y.	-	
54+84 TO 57+50	2' F.B. SURF.	CL. II	1'	496 T	15"	

USER: \$\$\$USER\$\$\$
 DATE: \$\$\$DATE\$\$\$
 FILE NAME: \$\$\$designsfiles\$\$\$specifications\$\$\$
 E-SHEET NAME:

AVERITT LUMBER ROAD
 APPR. RT. STA. 5177+49.11
 STA. 50+44 TO STA. 57+84.89

SCALE: 1"=50'

PREPARED BY _____ DATE _____
 CHECKED BY _____ DATE _____
 APPROVED BY _____ DATE _____

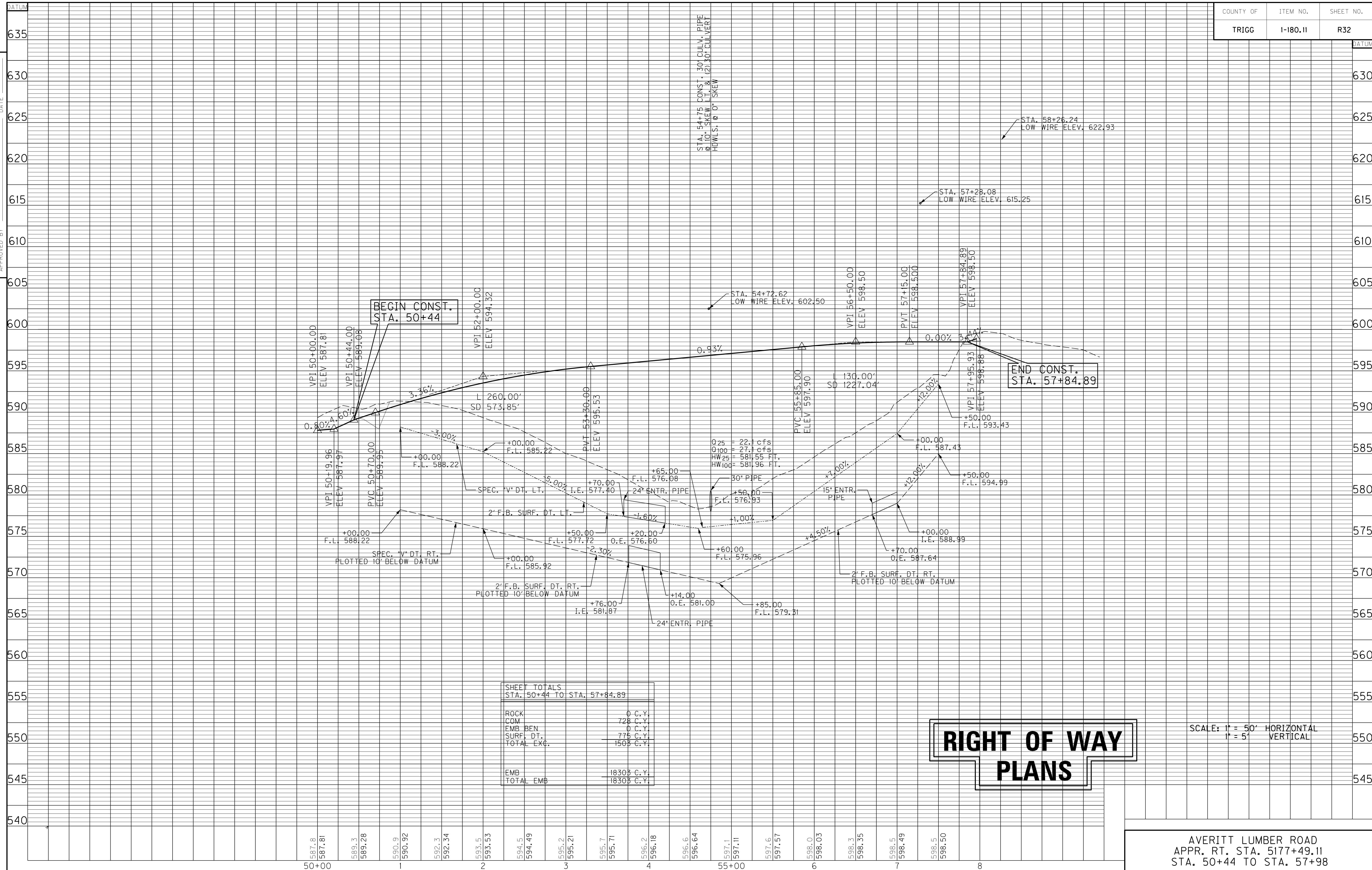

SHEET TOTALS	
STA. 50+44 TO STA. 57+84.89	
ROCK	0 C.Y.
COM	728 C.Y.
EMB BEN	0 C.Y.
SURF. DT.	775 C.Y.
TOTAL EXC.	1503 C.Y.
EMB	18303 C.Y.
TOTAL EMB	18303 C.Y.

RIGHT OF WAY PLANS

SCALE: 1" = 50' HORIZONTAL
1" = 5' VERTICAL

AVERITT LUMBER ROAD
APPR. RT. STA. 5177+49.11
STA. 50+44 TO STA. 57+98

USER: \$\$\$USER\$\$\$
 DATE: \$\$\$DATE\$\$\$
 FILE NAME: \$\$\$designsfilespecifications\$\$\$
 E-SHEET NAME:

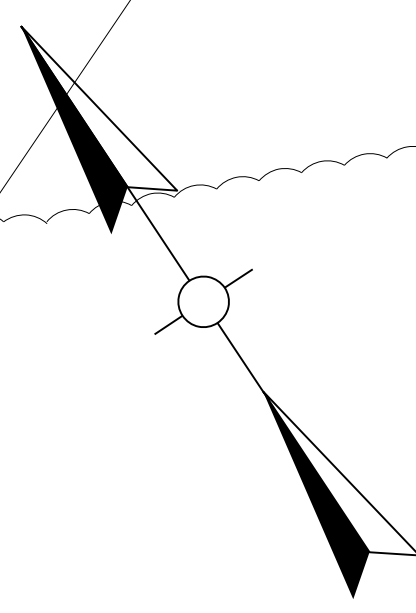

DITCH CONSTRUCTION LT ☺					
STA. TO STA.	SIZE/TYPE	CHANNEL LINING			
		TYPE	DEPTH	QUANTITY	T
45+15 TO 47+50	NORM.	ECB	1'	207 S.Y.	-
47+50 TO 48+07	SPEC. "V"	ECB	1'	52 S.Y.	-
48+50 TO 49+24	SPEC. "V"	ECB	1'	68 S.Y.	-

STA. 45+15 CONST.
14 LF OF EDGE KEY

LT. STA. 47+00 TO STA. 48+05
CONST. 124 LF OF WOVEN WIRE
FENCE TYPE 1

LT. STA. 46+18 CONST. 16'
ENTR. W/ 7 S.Y. APPROACH
PVMT. & 58 S.Y. ENTR. PVMT.

HERITAGE RD.
PI STA 44+19.66
 $\Delta = 30^\circ 27' 21''$ LT
T = 81.66'
L = 159.47'
R = 300.00'
E = 10.92'
e = SEE CROSS SECTIONS

PREPARED BY _____ DATE _____
CHECKED BY _____ DATE _____
APPROVED BY _____ DATE _____

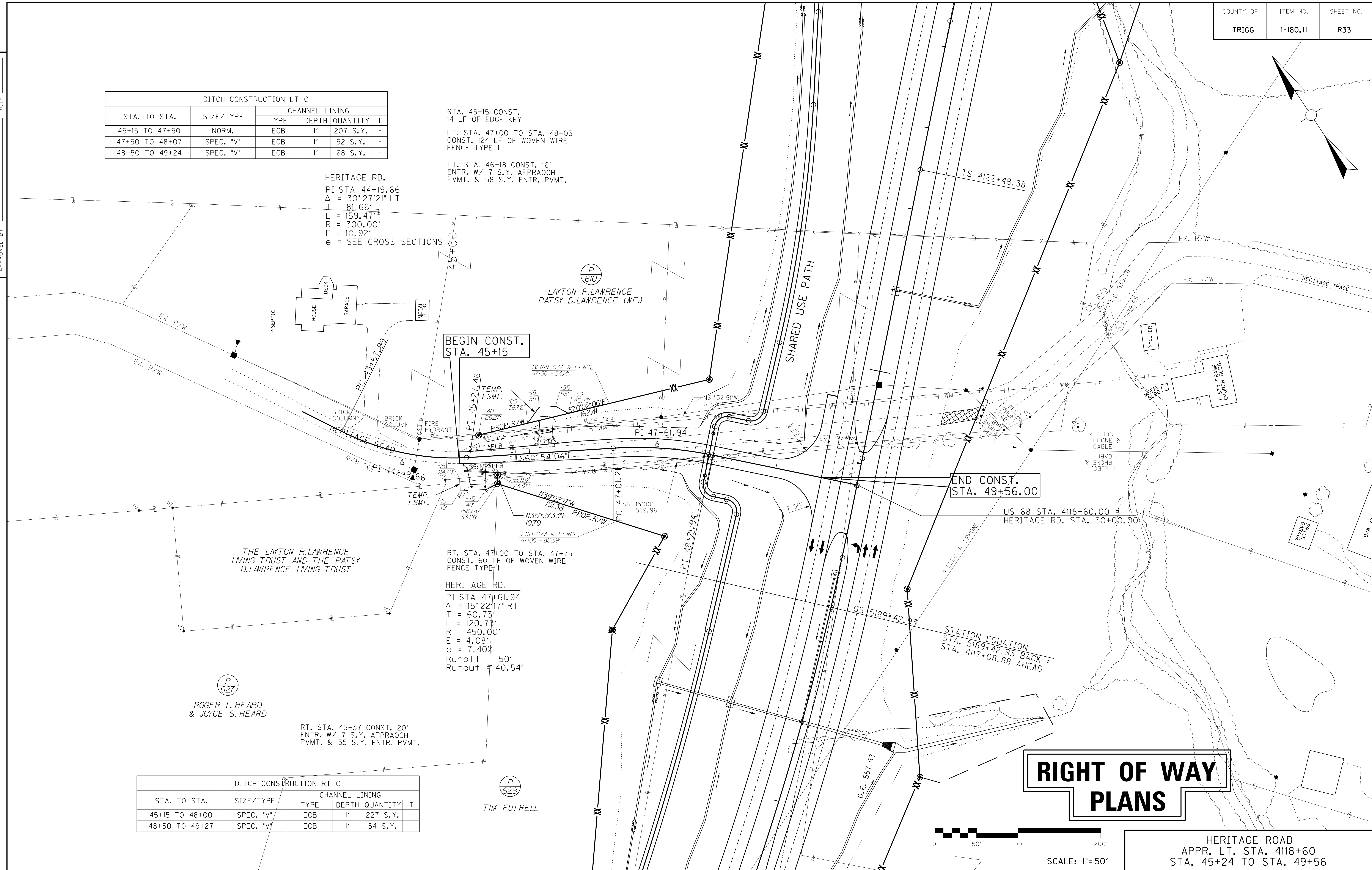

BEGIN CONST.
STA. 45+15

END CONST.
STA. 49+56.00

RT. STA. 47+00 TO STA. 47+75
CONST. 60 LF OF WOVEN WIRE
FENCE TYPE 1

HERITAGE RD.
PI STA 47+61.94
 $\Delta = 15^\circ 22' 17''$ RT
T = 60.73'
L = 120.73'
R = 450.00'
E = 4.08'
e = 7.40%
Runoff = 150'
Runout = 40.54'

RT. STA. 45+37 CONST. 20'
ENTR. W/ 7 S.Y. APPROACH
PVMT. & 55 S.Y. ENTR. PVMT.

DITCH CONSTRUCTION RT ☺					
STA. TO STA.	SIZE/TYPE	CHANNEL LINING			
		TYPE	DEPTH	QUANTITY	T
45+15 TO 48+00	SPEC. "V"	ECB	1'	227 S.Y.	-
48+50 TO 49+27	SPEC. "V"	ECB	1'	54 S.Y.	-

TIM FUTRELL

RIGHT OF WAY PLANS

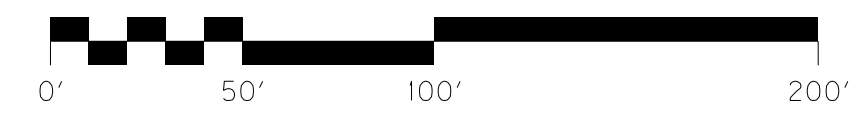

SCALE: 1"= 50'

HERITAGE ROAD
APPR. LT. STA. 4118+60
STA. 45+24 TO STA. 49+56

USER: \$\$\$USER\$\$\$\$
DATE: \$\$\$DATE\$\$\$\$
FILE NAME: \$\$\$designsfiles\$specifications\$\$\$
E-SHEET NAME:

PREPARED BY _____ DATE _____
 CHECKED BY _____ DATE _____
 APPROVED BY _____ DATE _____

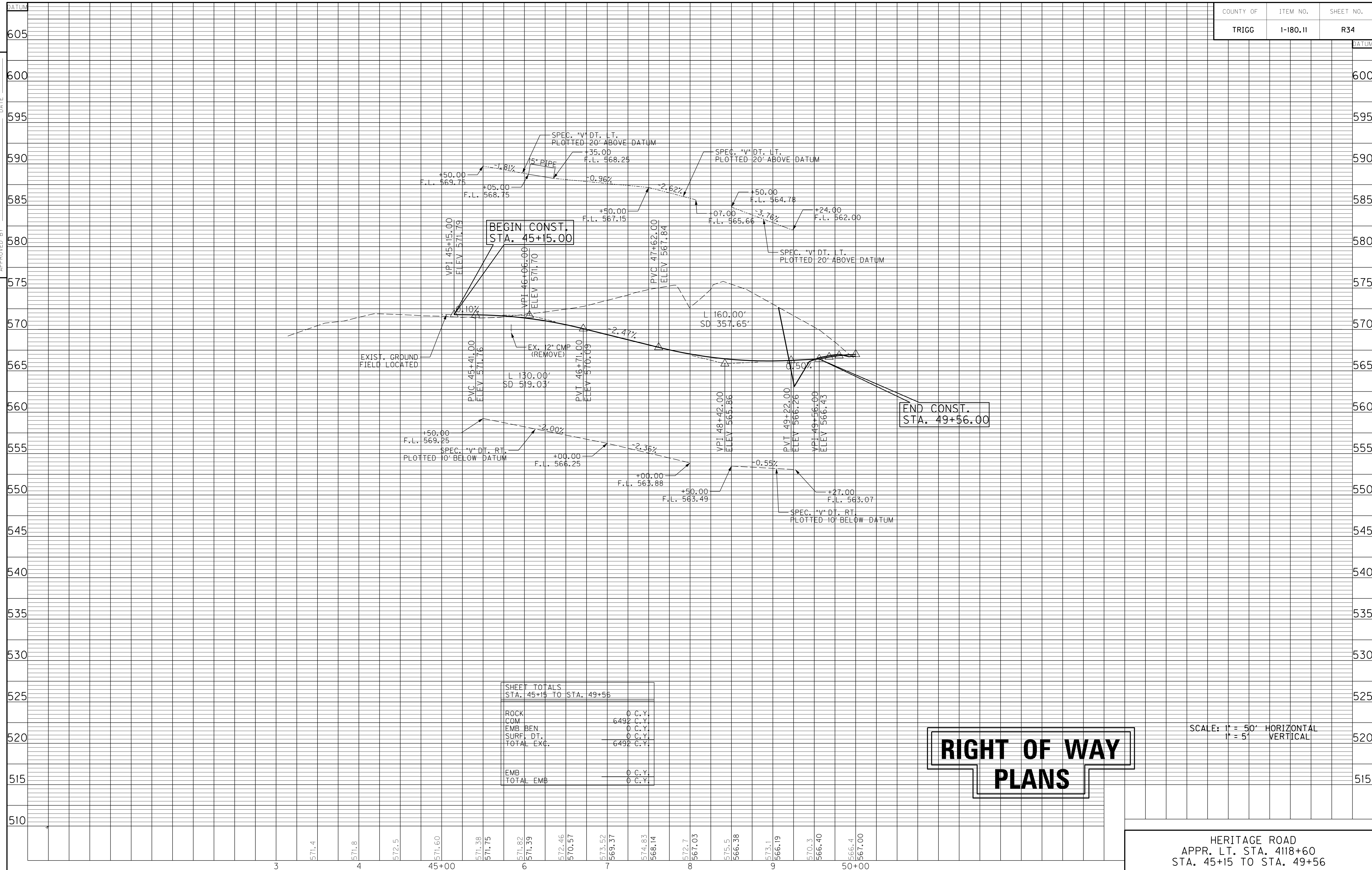

SHEET TOTALS	
STA. 45+15 TO STA. 49+56	
ROCK	0 C.Y.
COM.	6492 C.Y.
EMB. BEN	0 C.Y.
SURF. DT.	0 C.Y.
TOTAL EXC.	6492 C.Y.
EMB	0 C.Y.
TOTAL EMB	0 C.Y.

**RIGHT OF WAY
PLANS**

SCALE: 1" = 50' HORIZONTAL
1" = 5' VERTICAL

HERITAGE ROAD
APPR. LT. STA. 4118+60
STA. 45+15 TO STA. 49+56

USER: \$\$\$USER\$\$\$
 DATE: \$\$\$DATE\$\$\$
 FILE NAME: \$\$\$designsfilespecifications\$\$\$
 E-SHEET NAME:

RT STA. 47+40 U.S. 68 AT KY 272
CONST. 12' ENTRANCE W/
29 LF OF 15" ENTRANCE PIPE &
19 S.Y. OF APPROACH PVMT. &
26 S.Y. OF ENTRANCE PVMT.

STA. 47+20 U.S. 68
AT KY 272
CONST. 22 LF OF EDGE KEY

LT STA. 51+15 TO STA. 53+00 KY 272
CONST. 168 LF OF WOVEN WIRE
FENCE TYPE 1

RT STA. 54+91 U.S. 68 AT KY 272
CONST. 12' ENTRANCE W/
26 LF OF 15" ENTRANCE PIPE &
28 S.Y. OF APPROACH PVMT. &
103 S.Y. OF ENTRANCE PVMT.

RT STA. 51+20 TO STA. 53+00 KY 272
CONST. 204 LF OF WOVEN WIRE
FENCE TYPE 1

KY 272
BEGIN CONST.
STA. 50+44.00

US 68 STA. 4144+50.00 =
KY 272 STA. 50+00.00

KY 272
PI STA 54+70.45
 $\Delta = 51^{\circ}43'54"$ LT.
T = 363.63'
L = 677.17'
R = 750.00'
E = 83.50'
e = 5.85%
Runoff = 120'
Runout = 41.03'

TOM VINSON
ROGER VINSON
STEPHANIE VINSON PERRY
TRUSTEES OF VINSON CEMETERY

ACCESS TO CEMETARY
SHALL BE MAINTAINED
AT ALL TIMES.

US 68 AT KY 272
BEGIN CONST.
STA. 47+20.00

US 68 AT KY 272
END CONST.
STA. 49+89.00

KY272 DITCH CONSTRUCTION RT @					
STA. TO STA.	SIZE/TYPE	CHANNEL LINING			
		TYPE	DEPTH	QUANTITY	T
50+74 TO 52+00	SPEC. "V"	ECB	1'	89 S.Y.	-
52+00 TO 55+00	NORM.	ECB	1'	212 S.Y.	-
55+00 TO 55+67	SPEC. "V"	ECB	1'	47 S.Y.	-
56+85	OUTLET	CL. II	1'	9 T	15'
56+85 TO 57+37	2' F.B. SPEC.	ECB	1'	48 S.Y.	-
58+00 TO 59+14	2' F.B. SPEC.	ECB	1'	105 S.Y.	-

US 68 AT KY 272 DITCH CONSTRUCTION RT @					
STA. TO STA.	SIZE/TYPE	CHANNEL LINING			
		TYPE	DEPTH	QUANTITY	T
47+26 TO 49+17	SPEC. "V"	ECB	1'	175 S.Y.	-
49+17 TO 49+70	NORM.	ECB	1'	49 S.Y.	-
50+39 TO 51+00	2' F.B. SPEC.	ECB	1'	44 S.Y.	-
51+00 TO 52+85	2' F.B. SURF.	ECB	1'	133 S.Y.	-
52+85 TO 54+75	2' F.B. SURF.	ECB	1'	137 S.Y.	-
54+75 TO 55+50	SPEC. "V"	ECB	1'	82 S.Y.	-

US 68 AT KY 272 DITCH CONSTRUCTION LT @					
STA. TO STA.	SIZE/TYPE	CHANNEL LINING			
		TYPE	DEPTH	QUANTITY	T
47+20 TO 49+17	2' F.B. SPEC.	ECB	1'	183 S.Y.	-
49+17 TO 49+70	NORM.	ECB	1'	49 S.Y.	-
51+94	OUTLET	CL. II	1.5'	12 T	15'
51+96 TO 55+00	2' F.B. SPEC.	ECB	1'	219 S.Y.	-
55+00 TO 55+50	NORM.	ECB	1'	46 S.Y.	-

US 68 AT KY 272
PI STA 51+91.61
 $\Delta = 32^{\circ}33'05"$ RT
T = 337.21'
L = 656.19'
R = 1155.00'
E = 48.22'
e = 7.77%
Runoff = 210'
Runout = 54.05'

US 68 AT KY 272
BEGIN CONST.
STA. 50+11.00

KY 272 STA. 56+04.63 =
US 68 AT KY 272 STA. 50+00.00

KY 272 STA. 57+74.38 =
KY 1062 STA. 50+00.00

KY 1062
BEGIN CONST.
STA. 50+11.00

STA. 59+14 KY 272 CONST.
19 LF OF EDGE KEY

KY 272
END CONST.
STA. 59+14.00

KY 1062 DITCH CONSTRUCTION RT @					
STA. TO STA.	SIZE/TYPE	CHANNEL LINING			
		TYPE	DEPTH	QUANTITY	T
50+44 TO 53+94.21	2' F.B. SPEC.	CL. II	1.5'	308 T	15'

US 68 AT KY 272
END CONST.
STA. 55+50.00

KY 1062 DITCH CONSTRUCTION LT @					
STA. TO STA.	SIZE/TYPE	CHANNEL LINING			
		TYPE	DEPTH	QUANTITY	T
53+00 TO 53+94.21	NORM.	ECB	1'	86 S.Y.	-

KY272 DITCH CONSTRUCTION LT @					
STA. TO STA.	SIZE/TYPE	CHANNEL LINING			
		TYPE	DEPTH	QUANTITY	T
50+74 TO 52+50	SPEC. "V"	ECB	1'	124 S.Y.	-
52+50 TO 55+00	NORM.	ECB	1'	177 S.Y.	-
55+00 TO 55+71	SPEC. "V"	ECB	1'	54 S.Y.	-
56+50 TO 57+00	NORM.	ECB	1'	46 S.Y.	-
57+00 TO 59+14	2' F.B. SPEC.	ECB	1'	200 S.Y.	-

**RIGHT OF WAY
PLANS**

SCALE: 1"=50'

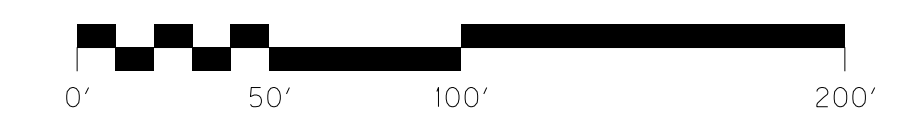

KY 272 (RT 4144+50) STA 50+44-59+14
US68 AT KY272 STA 47+20 TO STA 49+89
US68 AT KY272 STA 50+11 TO STA 55+50
KY 1062 STA 50+11 TO STA 53+94.21

PREPARED BY _____ DATE _____
CHECKED BY _____ DATE _____
APPROVED BY _____ DATE _____

USER: \$\$\$USER\$\$\$
DATE: \$\$\$DATE\$\$\$
FILE NAME: \$\$\$designs\$filespecification\$\$\$
E-SHEET NAME:

PREPARED BY _____ DATE _____
 CHECKED BY _____ DATE _____
 APPROVED BY _____ DATE _____

USER: \$\$\$USER\$\$\$
 DATE: \$\$\$DATE\$\$\$
 FILE NAME: \$\$\$designsfilespecifications\$\$\$
 E-SHEET NAME:

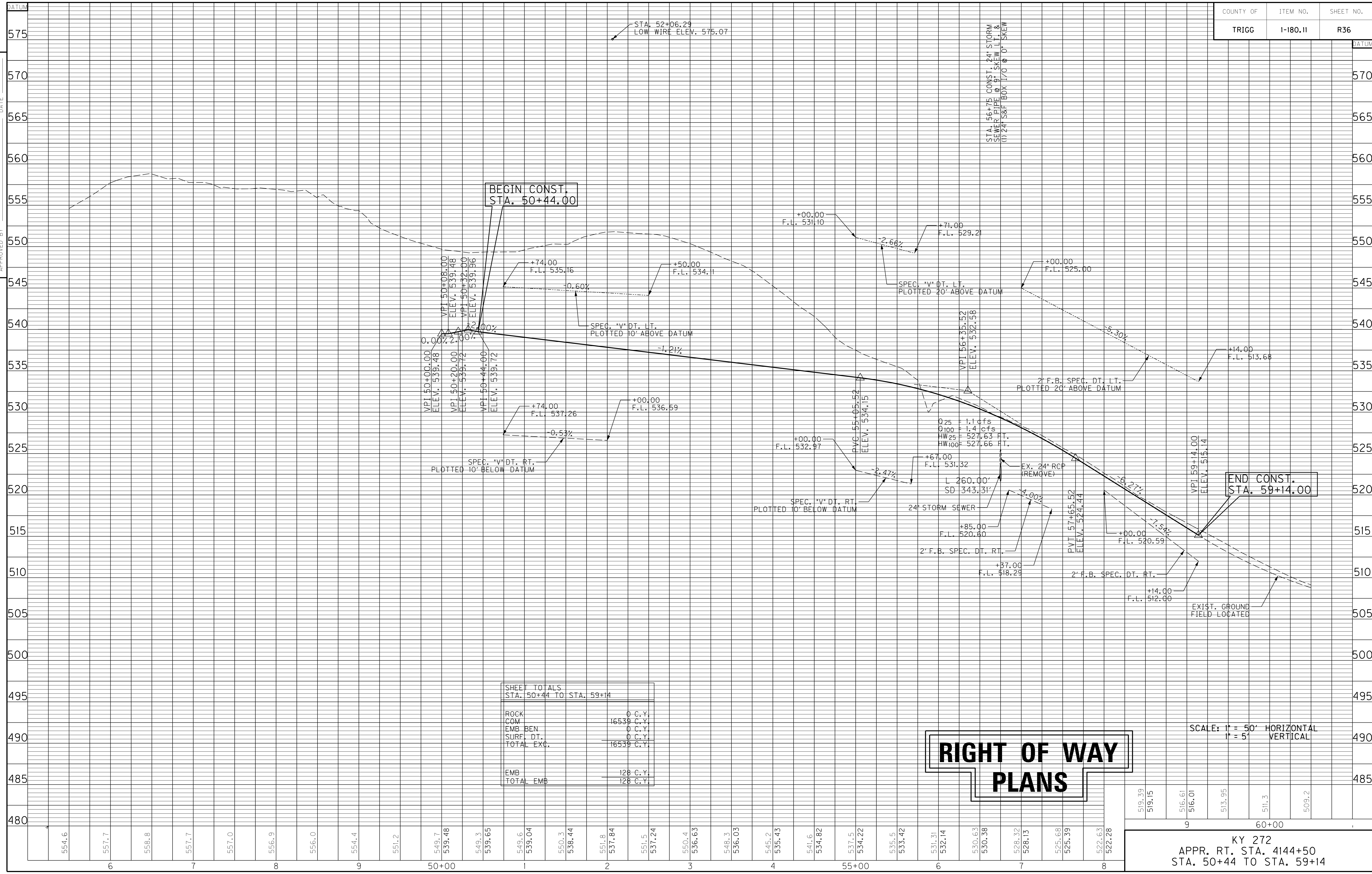

SHEET TOTALS	
STA. 50+44 TO STA. 59+14	
ROCK	0 C.Y.
COM	16539 C.Y.
EMB BEN	0 C.Y.
SUREL DT.	0 C.Y.
TOTAL EXC.	16539 C.Y.
EMB	128 C.Y.
TOTAL EMB	128 C.Y.

PREPARED BY _____ DATE _____
 CHECKED BY _____ DATE _____
 APPROVED BY _____ DATE _____

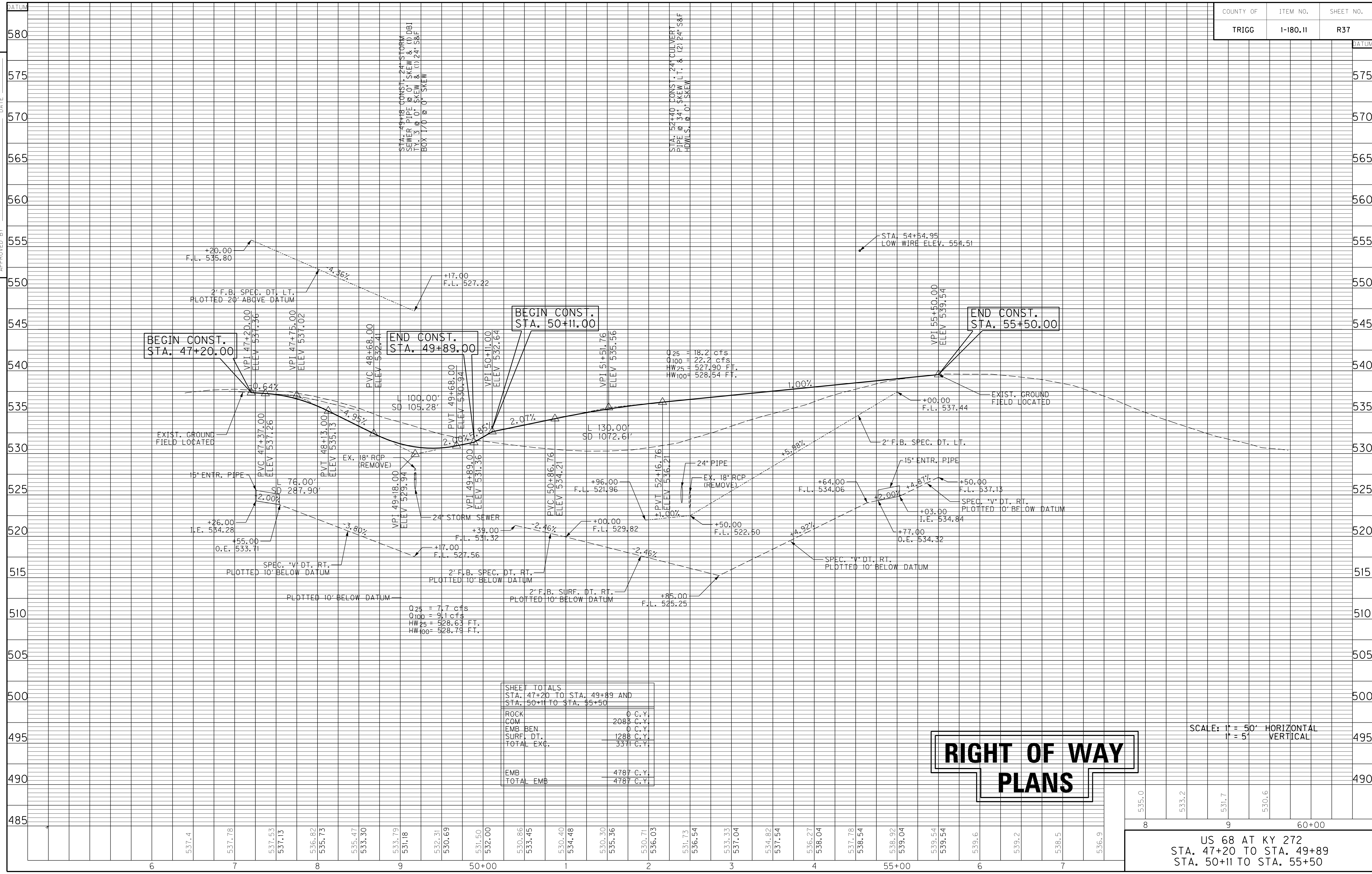

USER: \$\$\$USER\$\$\$
 DATE: \$\$\$DATE\$\$\$
 FILE NAME: \$\$\$designsfilespecifications\$\$\$
 E-SHEET NAME:

SHEET TOTALS	
STA. 47+20 TO STA. 49+89 AND	
STA. 50+11 TO STA. 55+50	
ROCK	0 C.Y.
COM	2088 C.Y.
EMB BEN	0 C.Y.
SURF. DT.	1288 C.Y.
TOTAL EXC.	3376 C.Y.
EMB	4787 C.Y.
TOTAL EMB	4787 C.Y.

RIGHT OF WAY PLANS

SCALE: 1" = 50' HORIZONTAL
1" = 5' VERTICAL

US 68 AT KY 272
 STA. 47+20 TO STA. 49+89
 STA. 50+11 TO STA. 55+50

535.0	533.2	531.7	530.6	60+00
-------	-------	-------	-------	-------

PREPARED BY _____ DATE _____
 CHECKED BY _____ DATE _____
 APPROVED BY _____ DATE _____

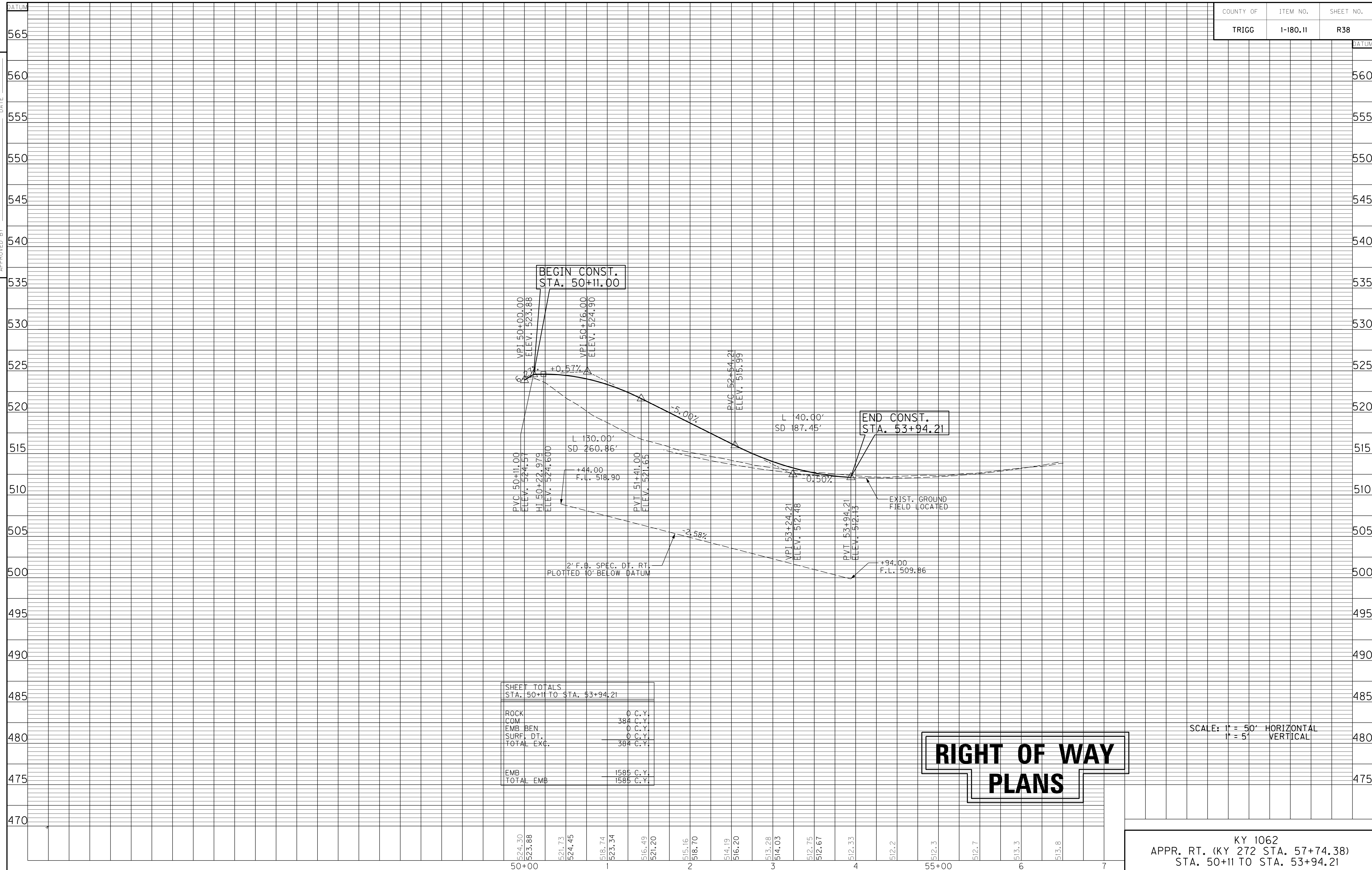

SHEET TOTALS	
STA. 50+11 TO STA. 53+94.21	
ROCK	0 C.Y.
COM.	384 C.Y.
EMB. BEN	0 C.Y.
SURF. DT.	0 C.Y.
TOTAL EXC.	384 C.Y.
EMB	1585 C.Y.
TOTAL EMB	1585 C.Y.

RIGHT OF WAY PLANS

SCALE: 1" = 50' HORIZONTAL
1" = 5' VERTICAL

USER: \$\$\$USER\$\$\$
 DATE: \$\$\$DATE\$\$\$
 FILE NAME: \$\$\$designsfilespecifications\$\$\$
 E-SHEET NAME:

PREPARED BY _____ DATE _____
 CHECKED BY _____ DATE _____
 APPROVED BY _____ DATE _____

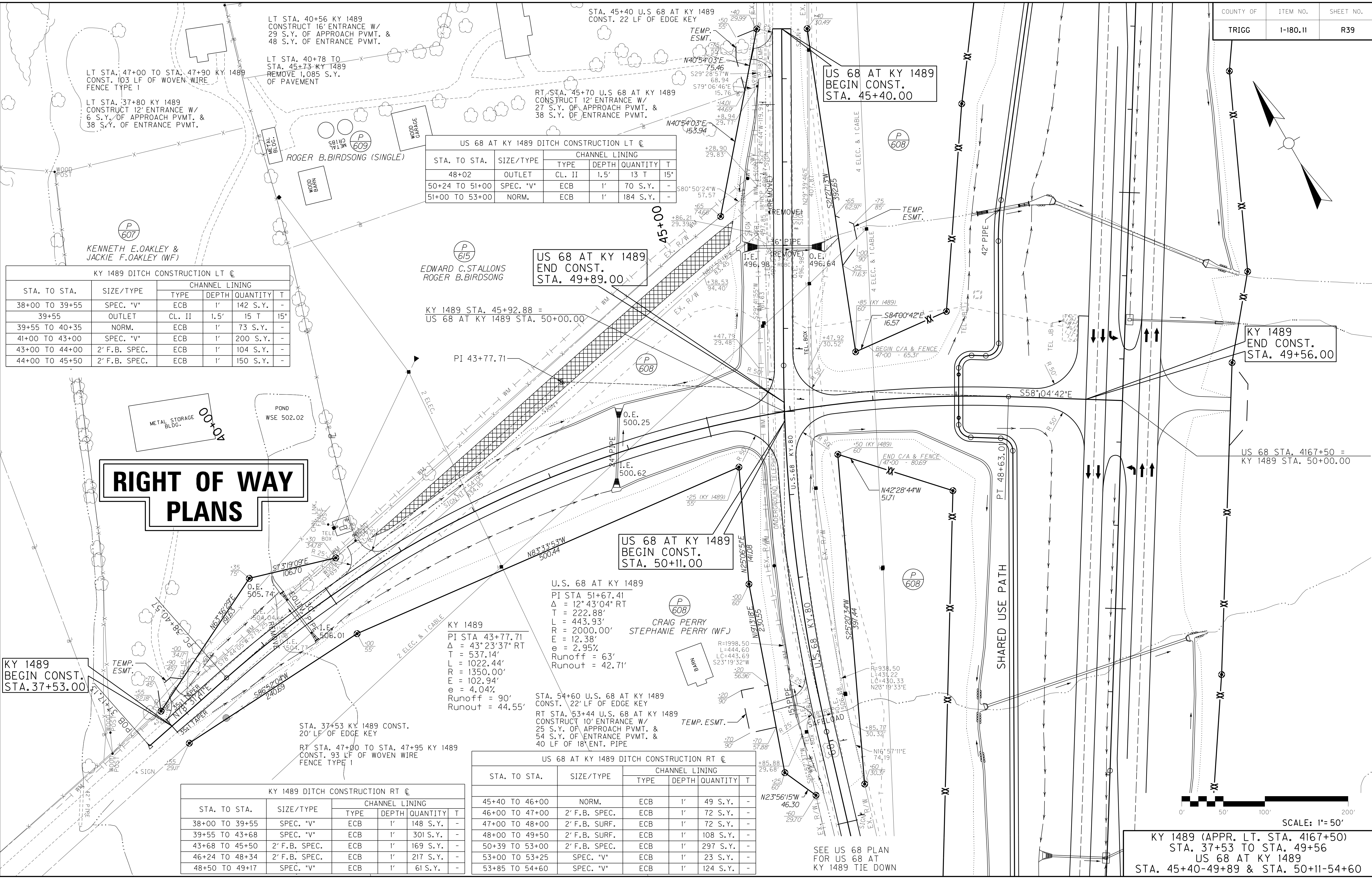

RIGHT OF WAY PLANS

KY 1489 DITCH CONSTRUCTION LT ☉

STA. TO STA.	SIZE/TYPE	CHANNEL LINING			T
		TYPE	DEPTH	QUANTITY	
38+00 TO 39+55	SPEC. "V"	ECB	1'	142 S.Y.	-
39+55	OUTLET	CL. II	1.5'	15 T	15'
39+55 TO 40+35	NORM.	ECB	1'	73 S.Y.	-
41+00 TO 43+00	SPEC. "V"	ECB	1'	200 S.Y.	-
43+00 TO 44+00	2' F.B. SPEC.	ECB	1'	104 S.Y.	-
44+00 TO 45+50	2' F.B. SPEC.	ECB	1'	150 S.Y.	-

US 68 AT KY 1489 DITCH CONSTRUCTION LT ☉

STA. TO STA.	SIZE/TYPE	CHANNEL LINING			T
		TYPE	DEPTH	QUANTITY	
48+02	OUTLET	CL. II	1.5'	13 T	15'
50+24 TO 51+00	SPEC. "V"	ECB	1'	70 S.Y.	-
51+00 TO 53+00	NORM.	ECB	1'	184 S.Y.	-

KY 1489 DITCH CONSTRUCTION RT ☉

STA. TO STA.	SIZE/TYPE	CHANNEL LINING			T
		TYPE	DEPTH	QUANTITY	
38+00 TO 39+55	SPEC. "V"	ECB	1'	148 S.Y.	-
39+55 TO 43+68	SPEC. "V"	ECB	1'	301 S.Y.	-
43+68 TO 45+50	2' F.B. SPEC.	ECB	1'	169 S.Y.	-
46+24 TO 48+34	2' F.B. SPEC.	ECB	1'	217 S.Y.	-
48+50 TO 49+17	SPEC. "V"	ECB	1'	61 S.Y.	-

US 68 AT KY 1489 DITCH CONSTRUCTION RT ☉

STA. TO STA.	SIZE/TYPE	CHANNEL LINING			T
		TYPE	DEPTH	QUANTITY	
45+40 TO 46+00	NORM.	ECB	1'	49 S.Y.	-
46+00 TO 47+00	2' F.B. SPEC.	ECB	1'	72 S.Y.	-
47+00 TO 48+00	2' F.B. SURF.	ECB	1'	72 S.Y.	-
48+00 TO 49+50	2' F.B. SURF.	ECB	1'	108 S.Y.	-
50+39 TO 53+00	2' F.B. SPEC.	ECB	1'	297 S.Y.	-
53+00 TO 53+25	SPEC. "V"	ECB	1'	23 S.Y.	-
53+85 TO 54+60	SPEC. "V"	ECB	1'	124 S.Y.	-

U.S. 68 AT KY 1489
 PI STA 51+67.41
 $\Delta = 12^\circ 43' 04''$ RT
 T = 222.88'
 L = 443.93'
 R = 2000.00'
 E = 12.38'
 e = 2.95%
 Runoff = 63'
 Runout = 42.71'

KY 1489
 PI STA 43+77.71
 $\Delta = 43^\circ 23' 37''$ RT
 T = 537.14'
 L = 1022.44'
 R = 1350.00'
 E = 102.94'
 e = 4.04%
 Runoff = 90'
 Runout = 44.55'

STA. 54+60 U.S. 68 AT KY 1489
 CONST. 22' LF OF EDGE KEY
 RT STA. 53+44 U.S. 68 AT KY 1489
 CONSTRUCT 10' ENTRANCE W/
 25 S.Y. OF APPROACH PVMT. &
 54 S.Y. OF ENTRANCE PVMT. &
 40 LF OF 18" ENT. PIPE

LT STA. 40+56 KY 1489
 CONSTRUCT 16' ENTRANCE W/
 29 S.Y. OF APPROACH PVMT. &
 48 S.Y. OF ENTRANCE PVMT.

LT STA. 40+78 TO
 STA. 45+73 KY 1489
 REMOVE 1,085 S.Y.
 OF PAVEMENT

STA. 45+40 U.S. 68 AT KY 1489
 CONST. 22 LF OF EDGE KEY

RT STA. 45+70 U.S. 68 AT KY 1489
 CONSTRUCT 12' ENTRANCE W/
 27 S.Y. OF APPROACH PVMT. &
 38 S.Y. OF ENTRANCE PVMT.

LT STA. 47+00 TO STA. 47+90 KY 1489
 CONST. 103 LF OF WOVEN WIRE
 FENCE TYPE 1

LT STA. 37+80 KY 1489
 CONSTRUCT 12' ENTRANCE W/
 6 S.Y. OF APPROACH PVMT. &
 38 S.Y. OF ENTRANCE PVMT.

KENNETH E. OAKLEY &
 JACKIE F. OAKLEY (WF)

EDWARD C. STALLONS
 ROGER B. BIRDSONG

US 68 AT KY 1489
 END CONST.
 STA. 49+89.00

KY 1489 STA. 45+92.88 =
 US 68 AT KY 1489 STA. 50+00.00

US 68 AT KY 1489
 BEGIN CONST.
 STA. 45+40.00

KY 1489
 END CONST.
 STA. 49+56.00

US 68 STA. 4167+50 =
 KY 1489 STA. 50+00.00

US 68 AT KY 1489
 BEGIN CONST.
 STA. 50+11.00

CRAIG PERRY
 STEPHANIE PERRY (WF)

KY 1489
 BEGIN CONST.
 STA. 37+53.00

SEE US 68 PLAN
 FOR US 68 AT
 KY 1489 TIE DOWN

KY 1489 (APPR. LT. STA. 4167+50)
 STA. 37+53 TO STA. 49+56
 US 68 AT KY 1489
 STA. 45+40-49+89 & STA. 50+11-54+60

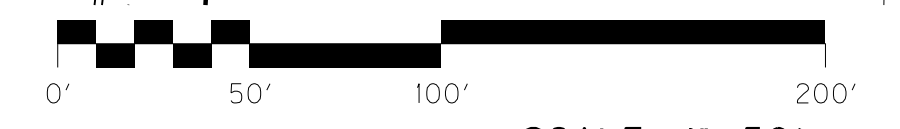

SCALE: 1" = 50'

USER: \$\$\$USER\$\$\$\$
 DATE: \$\$\$DATE\$\$\$\$
 FILE NAME: \$\$\$designsfiles\$specifications\$\$\$
 E-SHEET NAME:

PREPARED BY _____ DATE _____
 CHECKED BY _____ DATE _____
 APPROVED BY _____ DATE _____

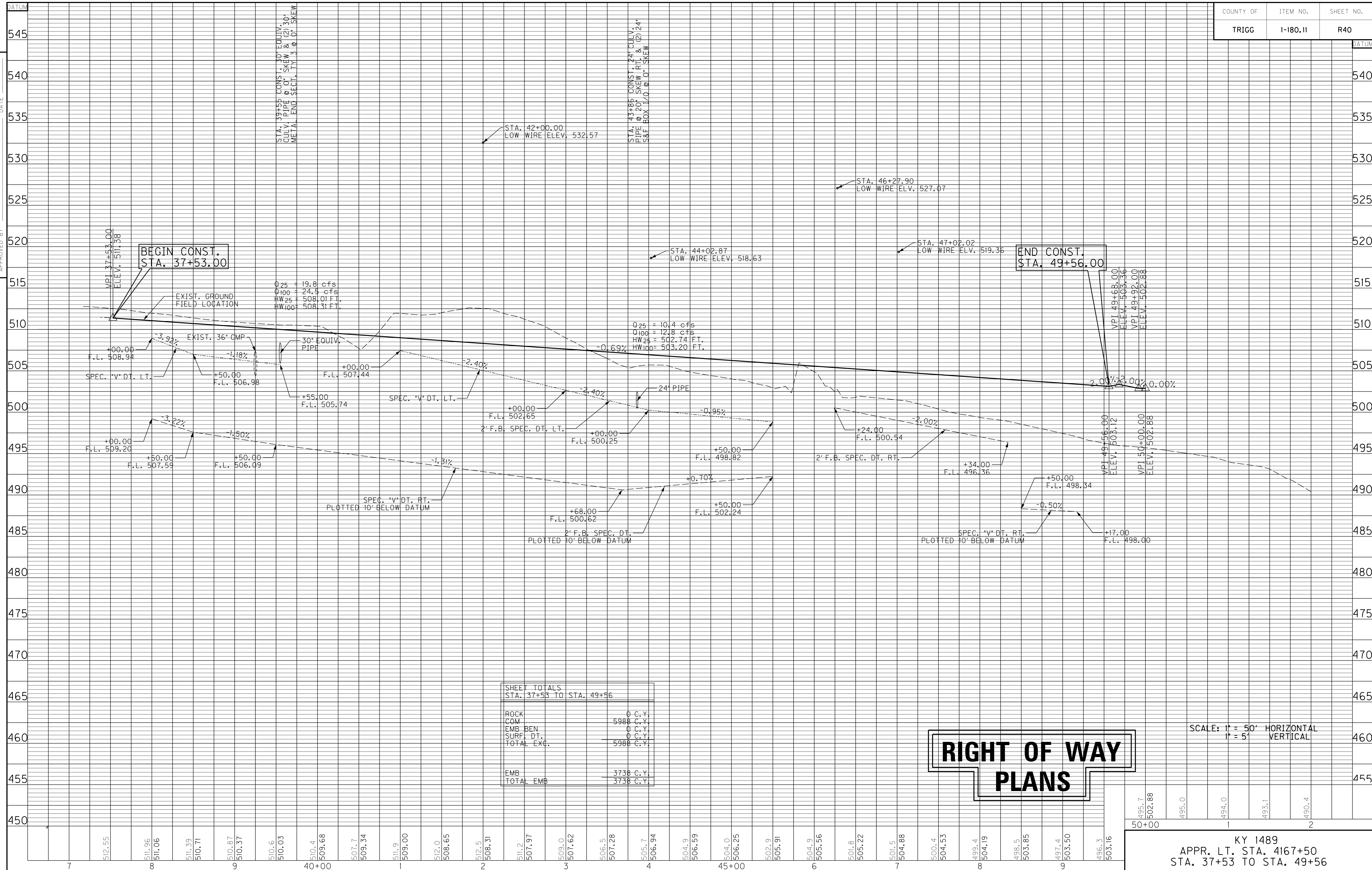

STA. 39+55 CONST. 30' EQUIV.
 CULV. PIPE @ 0.07° SKEW & (2) 30'
 METAL END SECT. @ 0.0° SKEW
 Q25 = 19.8 cfs
 Q100 = 24.5 cfs
 HW25 = 508.01 FT.
 HW100 = 508.31 FT.

STA. 43+85 CONST. 24' CULV.
 PIPE @ 20° SKEW RT. & (2) 24'
 S&F BOX T/O @ 0° SKEW
 Q25 = 10.4 cfs
 Q100 = 12.8 cfs
 HW25 = 502.74 FT.
 HW100 = 503.20 FT.

SHEET TOTALS	
STA. 37+53 TO STA. 49+56	
ROCK	0 C.Y.
COM	5988 C.Y.
EMB BEN	0 C.Y.
SURF. DT.	0 C.Y.
TOTAL EXC.	5988 C.Y.
EMB	3738 C.Y.
TOTAL EMB	3738 C.Y.

RIGHT OF WAY PLANS

SCALE: 1" = 50' HORIZONTAL
 1" = 5' VERTICAL

USER: \$\$\$USER\$\$\$
 DATE: \$\$\$DATE\$\$\$
 FILE NAME: \$\$\$designsfilespecifications\$\$\$
 E-SHEET NAME:

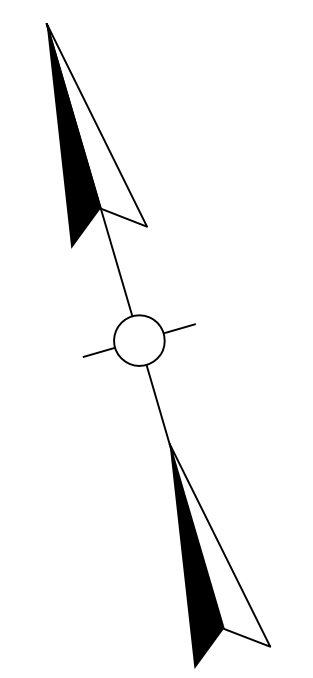

PREPARED BY _____ DATE _____
 CHECKED BY _____ DATE _____
 APPROVED BY _____ DATE _____

MACK CUNNINGHAM ROAD
 PI STA 51+82.20
 $\Delta = 15^\circ 27' 26''$ LT
 T = 67.86'
 L = 134.89'
 R = 500.00'
 E = 4.58'
 $e = 7.11\%$
 Runoff = 135'
 Runout = 38.26'

STA. TO STA.	SIZE/TYPE	CHANNEL LINING		
		TYPE	DEPTH	QUANTITY
51+00 TO 51+97	2' F.B. SPEC.	ECB	1'	70 S.Y.
51+97 TO 53+66	SPEC. "V"	ECB	1'	144 S.Y.

STA. TO STA.	SIZE/TYPE	CHANNEL LINING		
		TYPE	DEPTH	QUANTITY
51+97	OUTLET	CL. II	1'	13 T 15'

BEGIN CONST. STA. 50+44.00

END CONST. STA. 53+66.46

RT STA. 51+25 TO STA. 53+00
 CONST. 191 LF OF WOVEN WIRE
 FENCE TYPE 1

STA. 53+66.46 CONST.
 9 LF. OF EDGE KEY.

RIGHT OF WAY PLANS

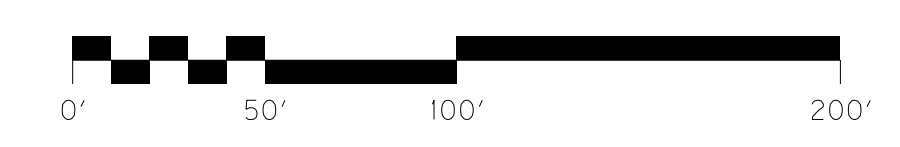

SCALE: 1"=50'

MACK CUNNINGHAM ROAD
 APPR. RT. STA. 4188+80
 STA. 50+44 TO STA. 53+66.46

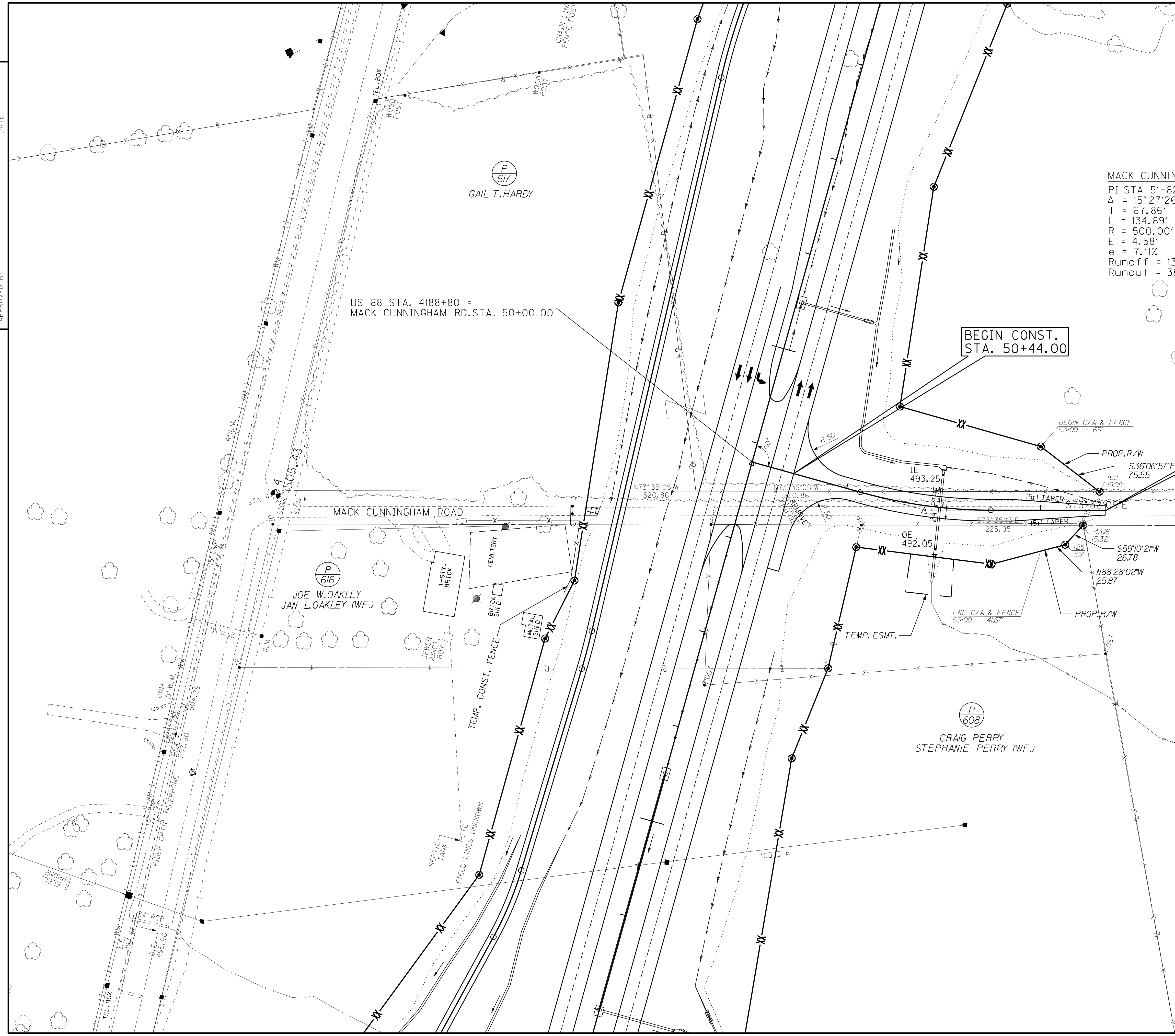

USER: \$\$\$USER\$\$\$
 DATE: \$\$\$DATE\$\$\$
 FILE NAME: \$\$\$designsfiles\$\$\$specifications\$\$\$
 E-SHEET NAME:

PREPARED BY _____ DATE _____
 CHECKED BY _____ DATE _____
 APPROVED BY _____ DATE _____

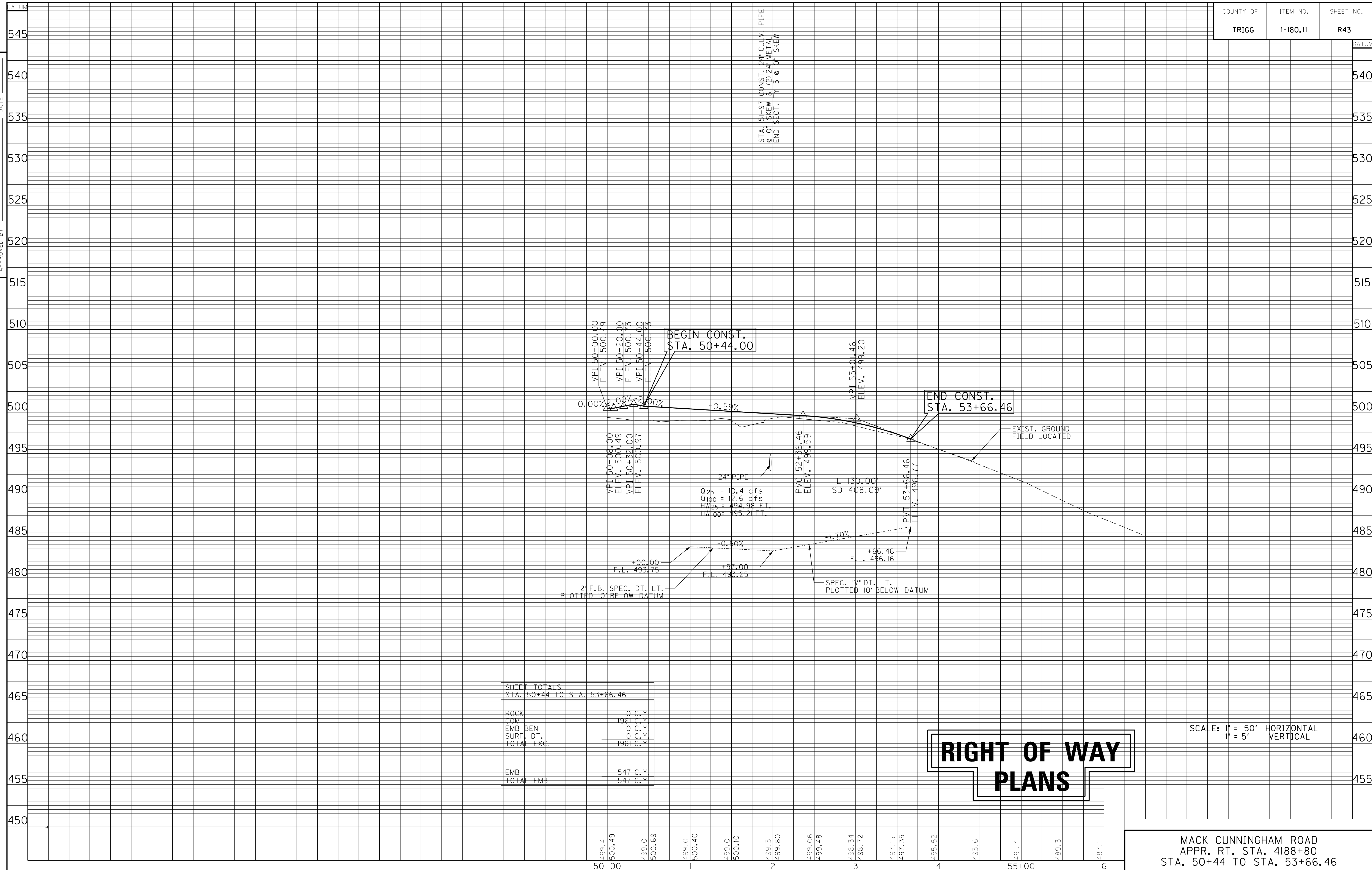

SHEET TOTALS	
STA. 50+44 TO STA. 53+66.46	
ROCK	0 C.Y.
COM.	1961 C.Y.
EMB. BEN	0 C.Y.
SURF. DT.	0 C.Y.
TOTAL EXC.	1961 C.Y.
EMB	547 C.Y.
TOTAL EMB	547 C.Y.

RIGHT OF WAY PLANS

SCALE: 1" = 50' HORIZONTAL
1" = 5' VERTICAL

MACK CUNNINGHAM ROAD
APPR. RT. STA. 4188+80
STA. 50+44 TO STA. 53+66.46

USER: \$\$\$USER\$\$\$
 DATE: \$\$\$DATE\$\$\$
 FILE NAME: \$\$\$designsfilespecifications\$\$\$
 E-SHEET NAME:

DITCH CONSTRUCTION LT @					
STA. TO STA.	SIZE/TYPE	CHANNEL LINING			
		TYPE	DEPTH	QUANTITY	T
42+00 TO 44+43	SPEC. "V"	ECB	1'	228 S.Y.	-
44+43	OUTLET	CL. II	1'	11 T	15'
45+42	OUTLET	CL. II	1'	11 T	15'
45+42 TO 46+00	SPEC. "V"	ECB	1'	53 S.Y.	-
46+00 TO 47+50	SPEC. "V"	ECB	1'	121 S.Y.	-
47+50 TO 48+96	2' F.B. SURF.	ECB	1'	115 S.Y.	-

LT STA. 41+72 CONST. 18' ENTRANCE W/ 41 S.Y. OF APPROACH PVMT. & 70 S.Y. OF ENTRANCE PVMT.

LT STA. 44+94 U.S. 68X (CANTON RD.) CONST. 16' ENTRANCE W/ 31 S.Y. OF APPROACH PVMT. & 106 S.Y. OF ENTRANCE PVMT.

STA. 41+30 U.S. 68X (CANTON RD.) CONST. 24 LF OF EDGE KEY

U.S. 68X (CANTON RD)
 PI STA 44+50.79
 $\Delta = 68^\circ 55' 32''$ LT
 T = 413.93'
 L = 725.53'
 R = 603.11'
 E = 128.38'
 e = 6.53%
 Runoff = 129'
 Runout = 39.51'

RT STA. 41+72 CONST. 20' ENTRANCE W/ 32 S.Y. OF APPROACH PVMT. & 52 S.Y. OF ENTRANCE PVMT.

DITCH CONSTRUCTION RT @					
STA. TO STA.	SIZE/TYPE	CHANNEL LINING			
		TYPE	DEPTH	QUANTITY	T
42+00 TO 43+00	NORM.	ECB	1'	113 S.Y.	-
43+00 TO 44+43	2' F.B. SPEC.	ECB	1'	138 S.Y.	-
45+42 TO 47+00	SPEC. "V"	ECB	1'	144 S.Y.	-
47+00 TO 48+96	SPEC. "V"	ECB	1'	164 S.Y.	-

RIGHT OF WAY PLANS

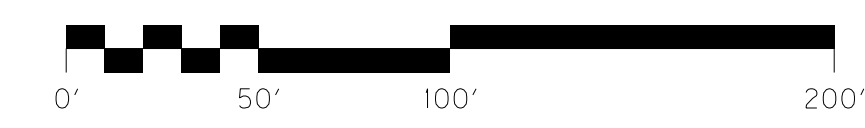

SCALE: 1"=50'

U.S. 68X (CANTON ROAD)
 APPR LT 4226+50 STA 41+30 TO 49+56
 BRAYBOY HANDLEY LN STA 50+11 TO 51+30

PREPARED BY _____ DATE _____
 CHECKED BY _____ DATE _____
 APPROVED BY _____ DATE _____

USER: \$\$\$USER\$\$\$
 DATE: \$\$\$DATE\$\$\$
 FILE NAME: \$\$\$designsfiles\$\$\$specifications\$\$\$
 E-SHEET NAME:

PREPARED BY _____ DATE _____
 CHECKED BY _____ DATE _____
 APPROVED BY _____ DATE _____

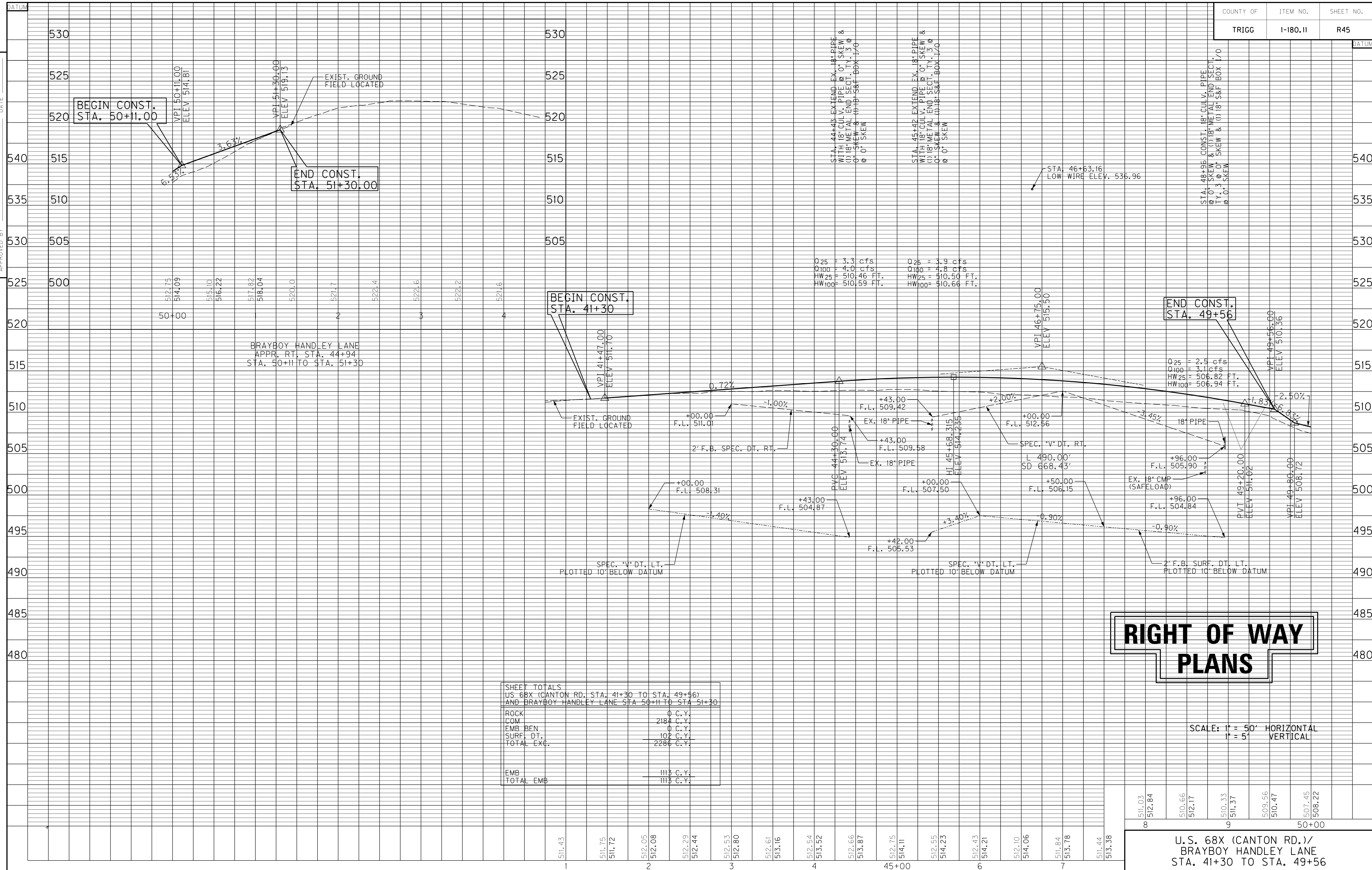

RIGHT OF WAY PLANS

SCALE: 1" = 50' HORIZONTAL
 1" = 5' VERTICAL

SHEET TOTALS	
US 68X (CANTON RD. STA. 41+30 TO STA. 49+56)	
AND BRAYBOY HANDLEY LANE STA 50+11 TO STA 51+30	
ROCK	0 C.Y.
COM.	218 C.Y.
EMB. BEN.	0 C.Y.
SURF. DT.	10 C.Y.
TOTAL EXC.	228 C.Y.
EMB.	113 C.Y.
TOTAL EMB.	113 C.Y.

511.03	512.84	510.66	512.17	510.33	511.37	509.56	510.47	507.45	508.22
8				9					
									50+00

U.S. 68X (CANTON RD.)/
 BRAYBOY HANDLEY LANE
 STA. 41+30 TO STA. 49+56

USER: \$\$\$USER\$\$\$
 DATE: \$\$\$DATE\$\$\$
 FILE NAME: \$\$\$designsfiles\$\$\$
 E-SHEET NAME:

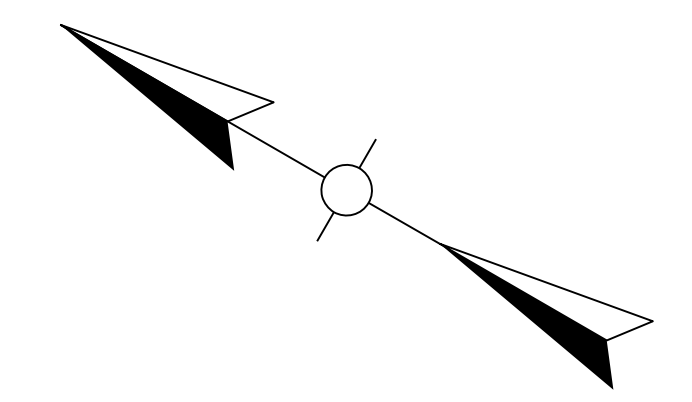

PREPARED BY _____ DATE _____
 CHECKED BY _____ DATE _____
 APPROVED BY _____ DATE _____

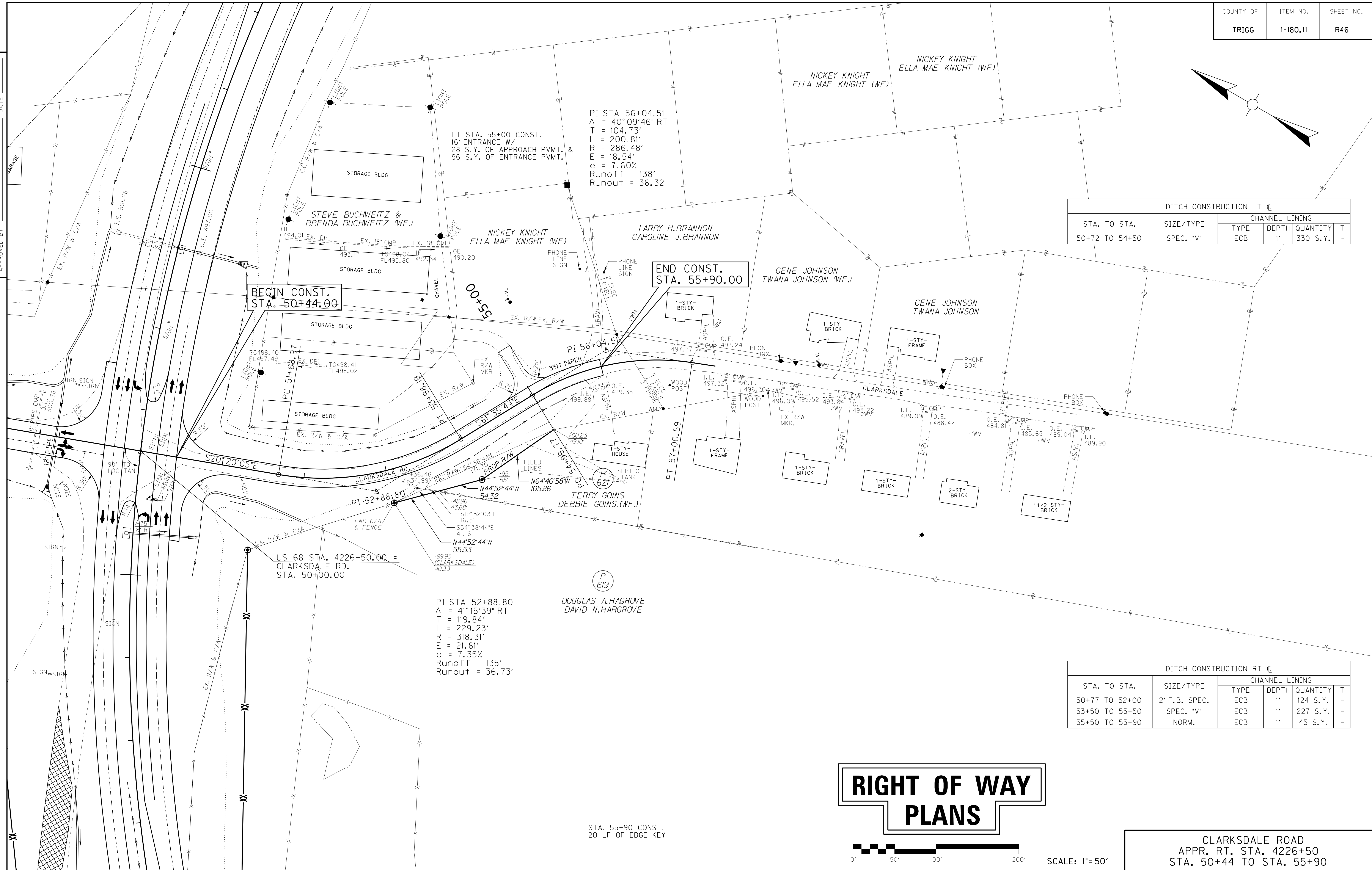

PI STA 56+04.51
 $\Delta = 40^{\circ}09'46''$ RT
 T = 104.73'
 L = 200.81'
 R = 286.48'
 E = 18.54'
 e = 7.60%
 Runoff = 138'
 Runout = 36.32

BEGIN CONST. STA. 50+44.00

END CONST. STA. 55+90.00

US 68 STA. 4226+50.00 =
 CLARKSDALE RD.
 STA. 50+00.00

PI STA 52+88.80
 $\Delta = 41^{\circ}15'39''$ RT
 T = 119.84'
 L = 229.23'
 R = 318.31'
 E = 21.81'
 e = 7.35%
 Runoff = 135'
 Runout = 36.73'

DOUGLAS A. HAGROVE
 DAVID N. HARGROVE

STA. 55+90 CONST.
 20 LF OF EDGE KEY

STA. TO STA.	SIZE/TYPE	CHANNEL LINING			
		TYPE	DEPTH	QUANTITY	T
50+72 TO 54+50	SPEC. "V"	ECB	1'	330 S.Y.	-

STA. TO STA.	SIZE/TYPE	CHANNEL LINING			
		TYPE	DEPTH	QUANTITY	T
50+77 TO 52+00	2' F.B. SPEC.	ECB	1'	124 S.Y.	-
53+50 TO 55+50	SPEC. "V"	ECB	1'	227 S.Y.	-
55+50 TO 55+90	NORM.	ECB	1'	45 S.Y.	-

RIGHT OF WAY PLANS

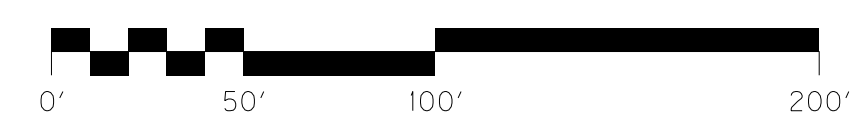

SCALE: 1"=50'

CLARKSDALE ROAD
 APPR. RT. STA. 4226+50
 STA. 50+44 TO STA. 55+90

USER: \$\$\$USER\$\$\$
 DATE: \$\$\$DATE\$\$\$
 FILE NAME: \$\$\$designsfiles\$\$\$specifications\$\$\$
 E-SHEET NAME:

PREPARED BY _____ DATE _____
 CHECKED BY _____ DATE _____
 APPROVED BY _____ DATE _____

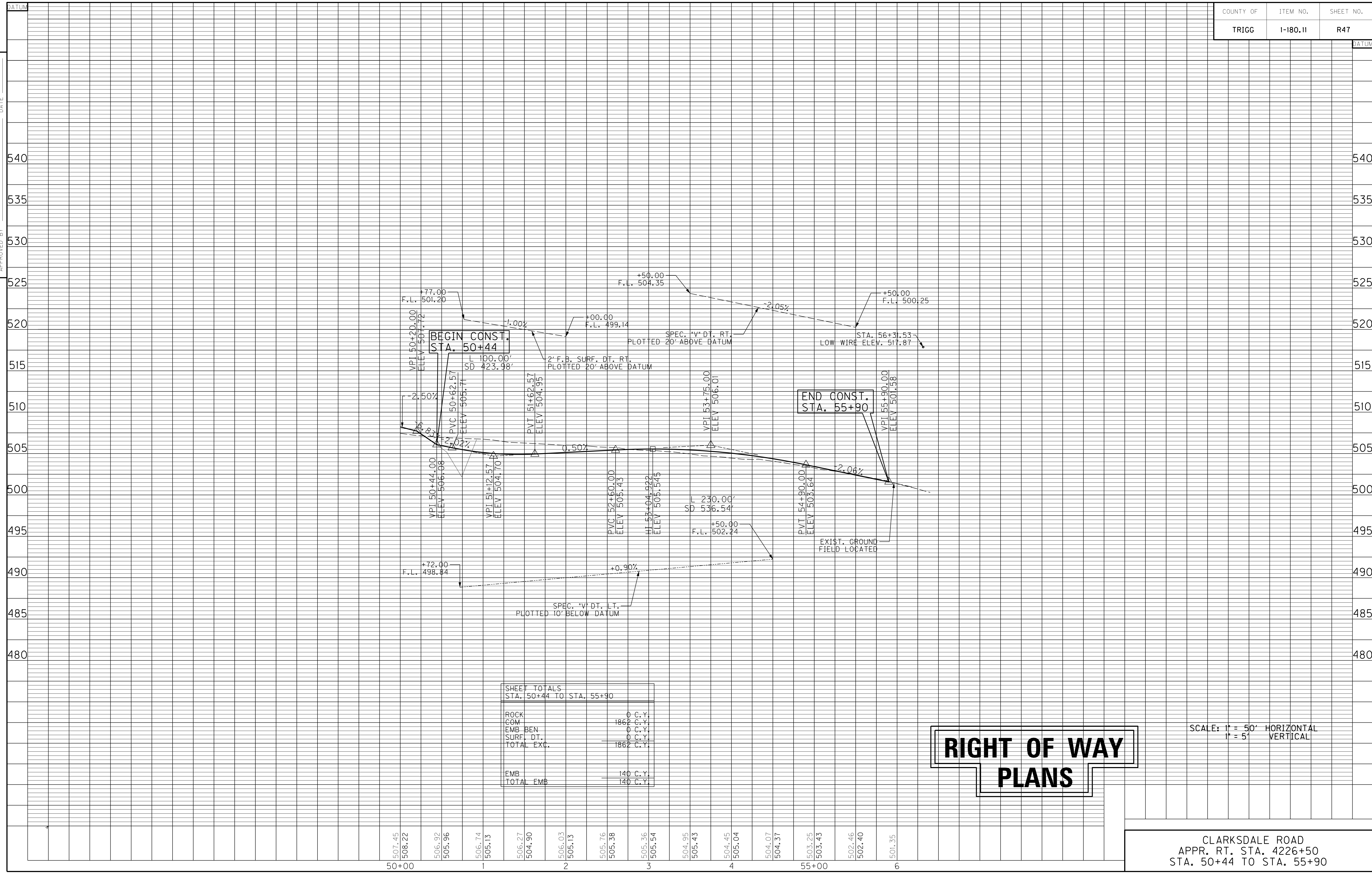

SHEET TOTALS	
STA. 50+44 TO STA. 55+90	
ROCK	0 C.Y.
COM	1862 C.Y.
EMB BEN	0 C.Y.
SURF. DT.	0 C.Y.
TOTAL EXC.	1862 C.Y.
EMB	140 C.Y.
TOTAL EMB	140 C.Y.

RIGHT OF WAY PLANS

SCALE: 1" = 50' HORIZONTAL
1" = 5' VERTICAL

CLARKSDALE ROAD
APPR. RT. STA. 4226+50
STA. 50+44 TO STA. 55+90

USER: \$\$\$USER\$\$\$
 DATE: \$\$\$DATE\$\$\$
 FILE NAME: \$\$\$designsfilespecifications\$\$\$
 E-SHEET NAME:

RIGHT OF WAY SUMMARY

PREPARED BY _____ DATE _____
 CHECKED BY _____ DATE _____
 APPROVED BY _____ DATE _____

PARCEL NO.	OWNER(S)	TOTAL AREA OF TRACT		PERMANENT R/W ACQUIRED		EASEMENTS		AREA SEVERED				EXCESS PURCHASED		PORTION REMAINING		SEWER SYSTEM TYPE	SEWER SYSTEM AFFECTED BY PROJECT		BUILDINGS ACQUIRED NUMBER					SOURCE OF TITLE	REMARKS (HAZARDOUS WASTE)
		ACRES	SQ. FT.	ACRES	SQ. FT.	PERMANENT	TEMPORARY	LEFT		RIGHT		ACRES	SQ. FT.	ACRES	SQ. FT.		YES	NO	C	R	F	S			
								SO. FT.	SO. FT.	ACRES	SO. FT.														
605	GLENORA CHISICK	1.210			36,036		2,625		12,716		3,956				16,672	1	X			1		1	D.B.191, PG.507 ; D.B.205, PG.169 D.B.215, PG.593 ; D.B.218, PG.563	a	
606	JOHN HAWKINS CONNIE HAWKINS (WF.)	2.390			8,820		790				2,187				2,187	1		X					D.B. 114, PG. 656 D.B. 138, PG. 434	c	
607	KENNETH E. OAKLEY JACKIE F. OAKLEY (WF.)	11.572			6,982		532	11,412							11,412	5							D.B. 135, PG. 356	a	
608	CRAIG PERRY STEPHANIE PERRY (WF.)	139.808		26.372		9,346	13,385	42,935		70,286					113,221	5							D.B. 238, PG. 337 D.B. 237, PG. 606	b	
609	ROGER B. BIRDSONG (SINGLE)	3.320			515		981			3,308					3,308	5							D.B. 219, PG. 656	a	
610	LAYTON R. LAWRENCE PATSY D. LAWRENCE (WF.)	5.509		1.812			487	3,457			10,454				3,697	1		X					D.B. 105, PG. 126 D.B. 209, PG. 427	c	
611	LARRY DAVID LAWRENCE ; BETTY LAWRENCE (WF.) WILLIAM DENNIS LAWRENCE;BARBARA JEAN LAWRENCE (WF.)	64.304		6.726			1,799	57,308			11,756				57,578	5							D.B. 161, PG. 615	a	
612	IRA L. BURGESS MELISSA L. BURGESS (WF.)	0.724			7,443		874		24,094						24,094	1		X					D.B. 159, PG. 1	a	
613	WILLIAM D. LAWRENCE ; DENNIS B. LAWRENCE BLY GOLLADAY; GLENDA B. LAWRENCE; LARRY D. LAWRENCE	114.775		23.018		14,202	6,251	23,842		67,589					91,431	5							D.B.122, PG.630 ; D.B.210, PG.432 D.B. 158, PG. 141	a	
615	EDWARD C. STALLONS RODGER B. BIRDSONG	3.068			3,740			2,982							2,982	5							D.B. 135, PG. 331 D.B. 159, PG. 71	a	
616	JOE W. OAKLEY JAN L. OAKLEY (WF.)	2.013			41,902			1,051							1,051	1		X					D.B. 144, PG. 523	a	
617	GAIL T. HARDY	72.050		15.415			6,809	8,713		47,922					56,635	1		X		1	3		D.B.97, PG.592 D.B.146, PG.87	a	
618	PINK H. AND BETTY S. GUIER TRUST	4.125		1.188				2,937							2,937	1	X				1		D.B.161, PG.324 ; D.B.184, PG.59 D.B. 205, PG. 528	c	
619	DOUGLAS A. HARGROVE DAVID N. HARGROVE	71.730		3.782			4,760	1,482		66,466					67,948	1	X		1	3			D.B.197, PG.27 ; D.B.102, PG.425 D.B. 234, PG. 557	b	
621	TERRY GOINS DEBBIE GOINS (WF.)	0.519			1,786					20,822					20,822	1	X						D.B. 178, PG. 300	a	
623	LEON BLAND CAROLYN BLAND (WF.)	28.338			12,487		20,358			28,051					28,051	5							D.B. 151, PG. 692	a	
624	WILLIAM D. LAWRENCE BARBARA J. LAWRENCE (WF.)	1.519			8,853		1,508	1,316							1,316	1		X					D.B. 158, PG. 141	a	
625	TOM VINSON ; ROGER VINSON ; STEPHANIE VINSON PERRY TRUSTEES OF VINSON CEMETERY		37,929			578				37,351					37,351	5							D.B. 107, PG. 247 D.B. 206, PG. 208	c	
626	JAMEY THOMAS ; MARTHA ARGOTTE	5.320			15,160					4,972					4,972	5							D.B. 261, PG. 305	a	
627	ROGER L. HEARD ; JOYCE S. HEARD	68.030		1.436			2,990	65,851			32,406				66,594	5							D.B. 259, PG. 699	a	
628	TIM FUTRELL	38.420		16.678		10,878	7,993	7,895		13,598					21,493	5							D.B. 259, PG. 690	a	

NOTE: PERMANENT R/W ACQUIRED + PERMANENT EASEMENT
+ AREA SEVERED = TOTAL AREA OF TRACT.

RIGHT OF WAY PLANS

BASIS FOR DETERMINATION OF AREA
 a. DEED
 b. P.V.A.
 c. CALCULATED
 d. OTHER

TYPE SEWER SYSTEM
 1. PRIVATE - INDIVIDUAL
 2. PRIVATE - MULTI PARTY
 3. PUBLIC
 4. NONE
 5. NOT APPLICABLE

BUILDINGS ACQUIRED CODE
 C - COMMERCIAL
 R - RESIDENTIAL
 F - FARM
 S - STORAGE

HAZARDOUS WASTE
 UST - UNDERGROUND STORAGE TANK

USER: \$\$\$USER\$\$\$
 DATE: \$\$\$DATE\$\$\$
 FILE NAME: \$\$\$designs\$files\$specific\$DEED\$ions\$\$\$
 E-SHEET NAME:

PREPARED BY _____ DATE _____
 CHECKED BY _____ DATE _____
 APPROVED BY _____ DATE _____

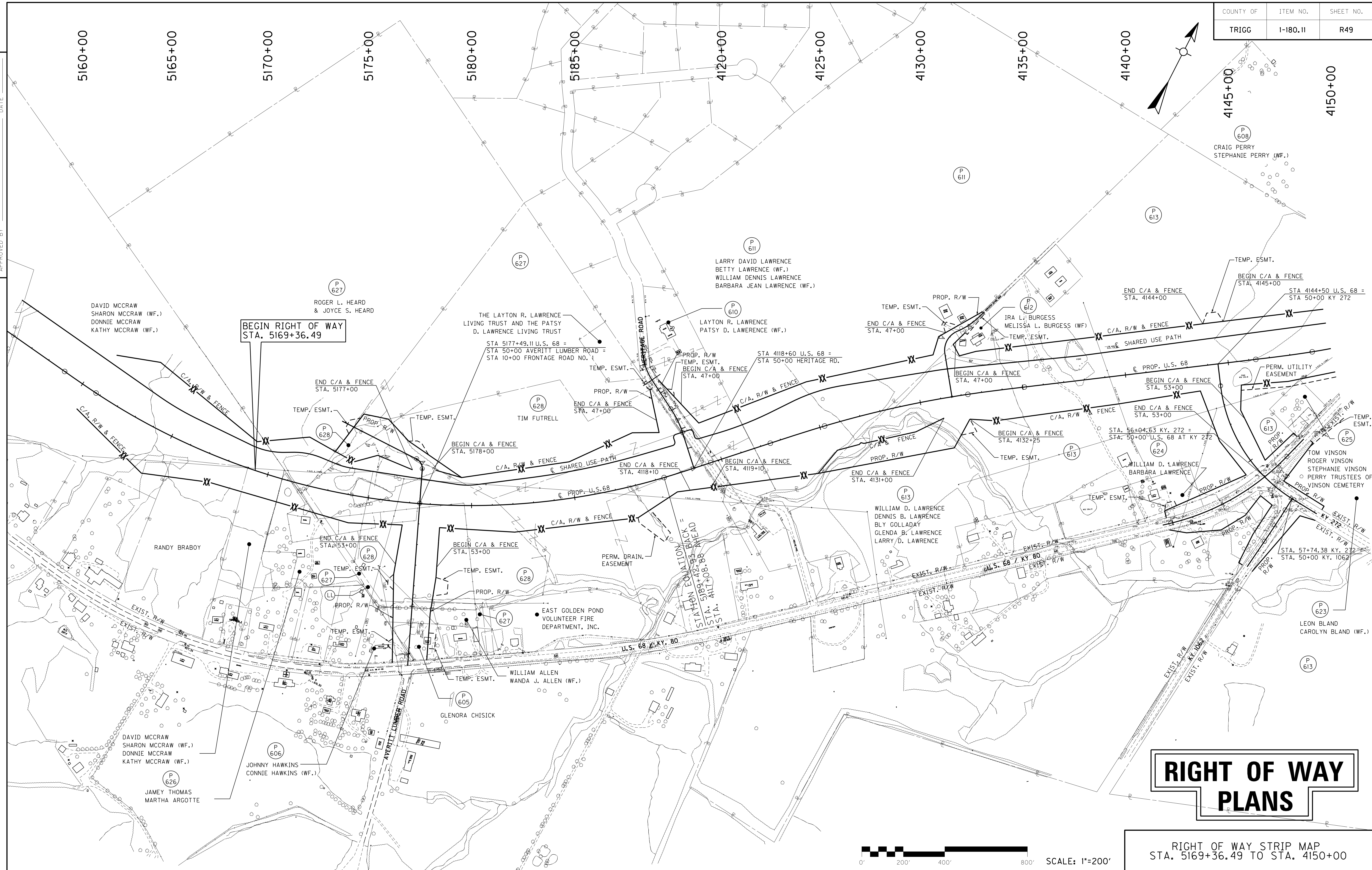

**BEGIN RIGHT OF WAY
STA. 5169+36.49**

RIGHT OF WAY PLANS

RIGHT OF WAY STRIP MAP
STA. 5169+36.49 TO STA. 4150+00



USER: \$\$\$USER\$\$\$
 DATE: \$\$\$DATE\$\$\$
 FILE NAME: \$\$\$designsfiles\$\$\$specifications\$\$\$
 E-SHEET NAME:

PREPARED BY _____ DATE _____
 CHECKED BY _____ DATE _____
 APPROVED BY _____ DATE _____

4150+00 4155+00 4160+00 4165+00 4170+00 4175+00 4180+00 4185+00 4190+00 4195+00 4200+00 4205+00 4210+00

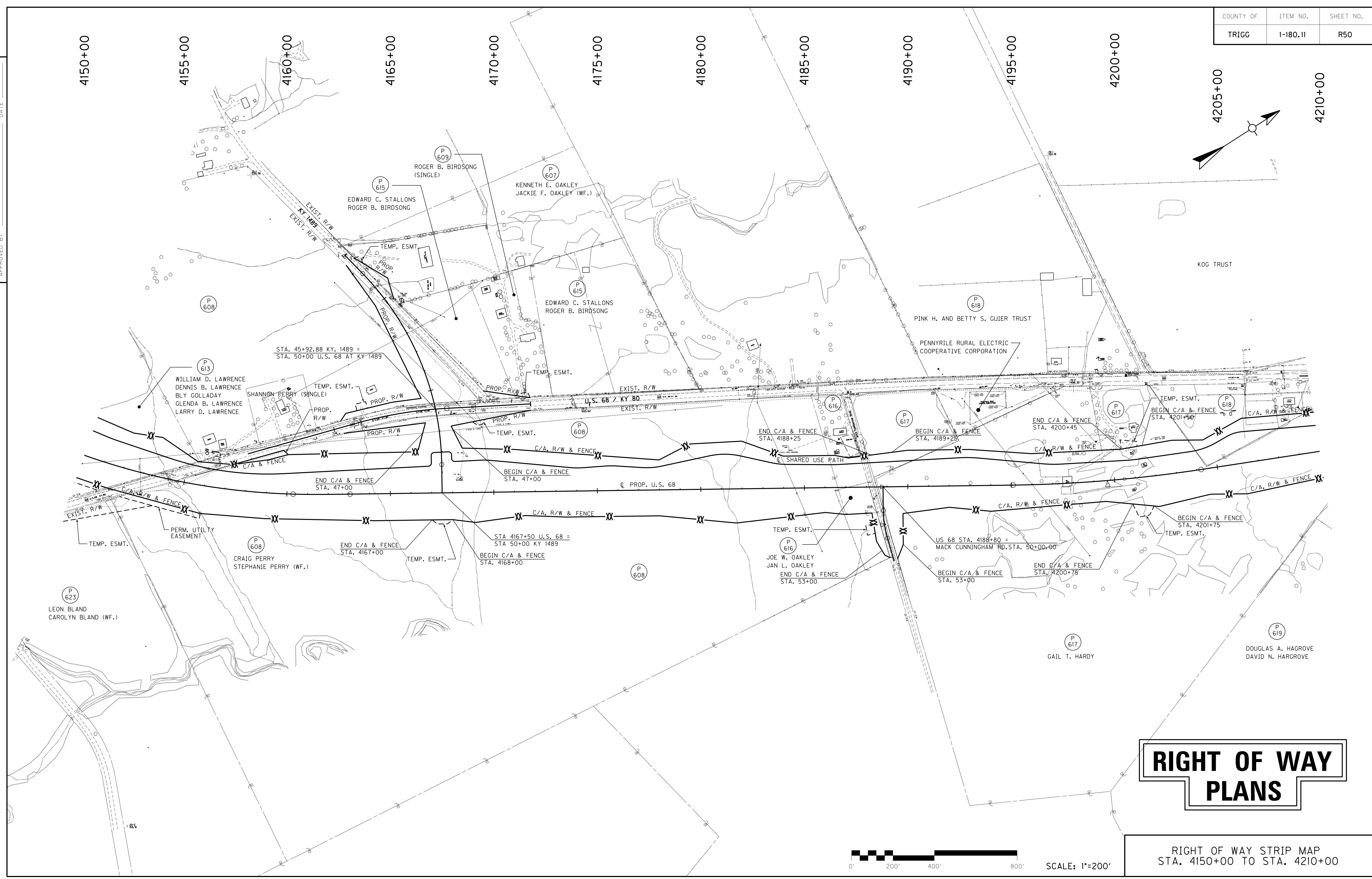
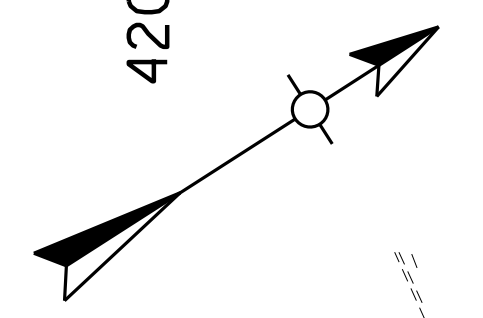

USER: \$\$\$USER\$\$\$
 DATE: \$\$\$DATE\$\$\$
 FILE NAME: \$\$\$designsfiles\$\$\$
 E-SHEET NAME:

RIGHT OF WAY PLANS



RIGHT OF WAY STRIP MAP
 STA. 4150+00 TO STA. 4210+00

PREPARED BY _____ DATE _____
 CHECKED BY _____ DATE _____
 APPROVED BY _____ DATE _____

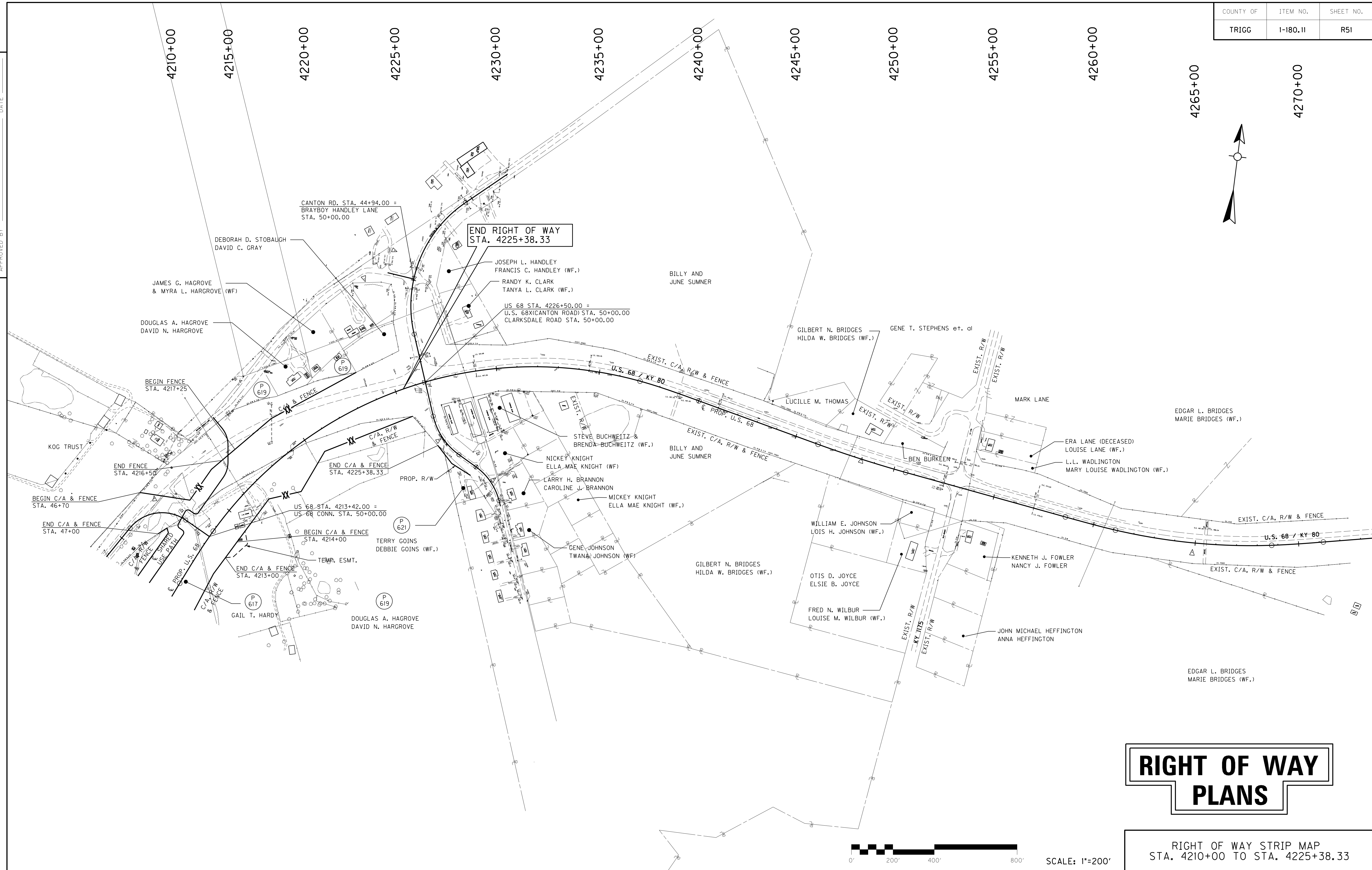

RIGHT OF WAY PLANS

RIGHT OF WAY STRIP MAP
 STA. 4210+00 TO STA. 4225+38.33

USER: \$\$\$USER\$\$\$
 DATE: \$\$\$DATE\$\$\$
 FILE NAME: \$\$\$designsfiles\$specifications\$\$\$
 E-SHEET NAME:

0' 200' 400' 800'
 SCALE: 1"=200'

PREPARED BY _____ DATE _____
 CHECKED BY _____ DATE _____
 APPROVED BY _____ DATE _____

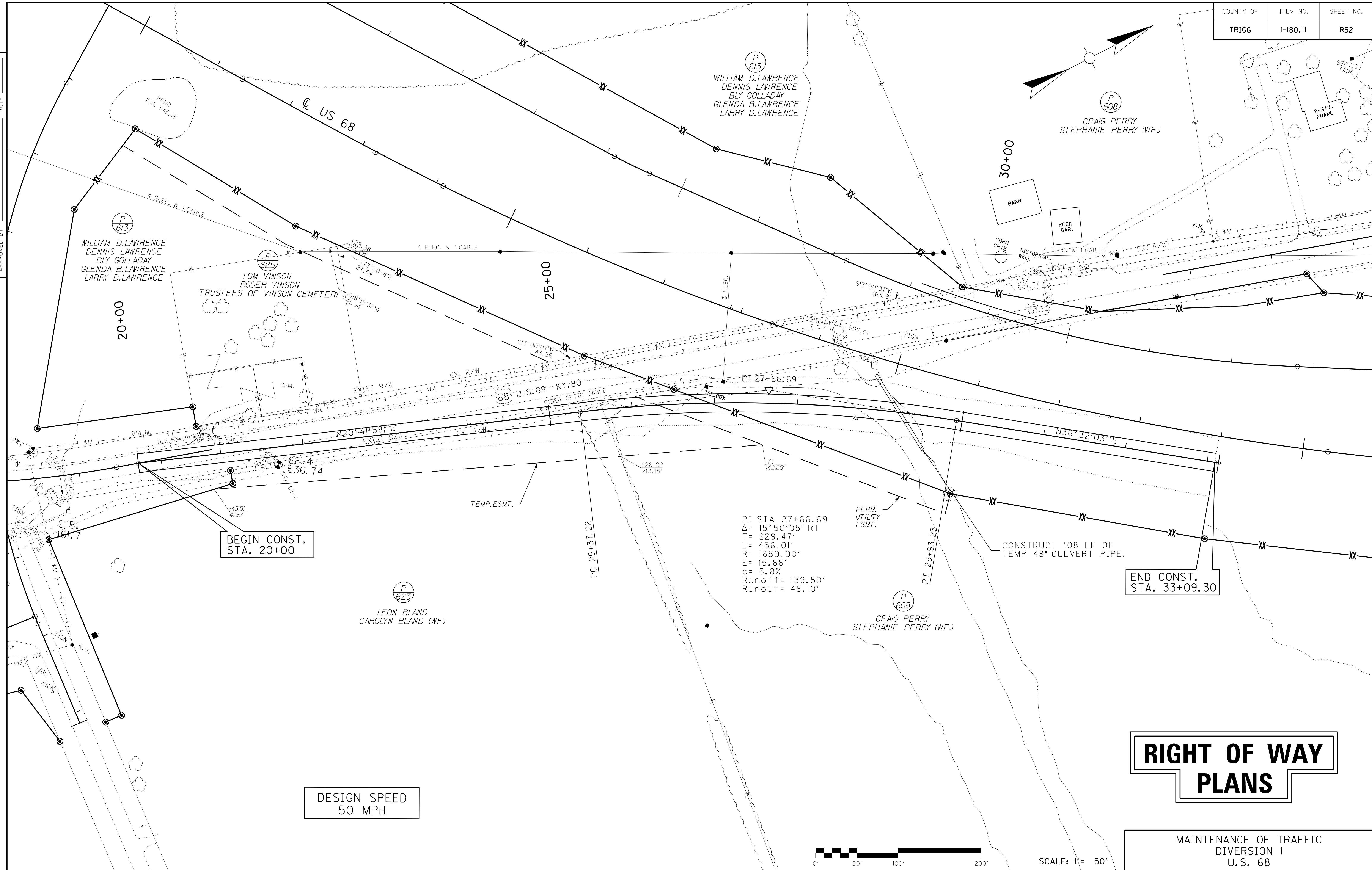

BEGIN CONST. STA. 20+00

END CONST. STA. 33+09.30

DESIGN SPEED
50 MPH

PI STA 27+66.69
 $\Delta = 15^\circ 50' 05''$ RT
 T = 229.47'
 L = 456.01'
 R = 1650.00'
 E = 15.88'
 e = 5.8%
 Runoff = 139.50'
 Runout = 48.10'

CONSTRUCT 108 LF OF TEMP 48" CULVERT PIPE.

RIGHT OF WAY PLANS

MAINTENANCE OF TRAFFIC DIVERSION 1
 U.S. 68

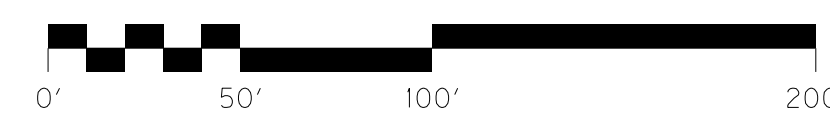

SCALE: 1" = 50'

USER: \$\$\$USER\$\$\$
 DATE: \$\$\$DATE\$\$\$
 FILE NAME: \$\$\$designsfiles\$\$\$specifications\$\$\$
 E-SHEET NAME:

PREPARED BY _____ DATE _____
 CHECKED BY _____ DATE _____
 APPROVED BY _____ DATE _____

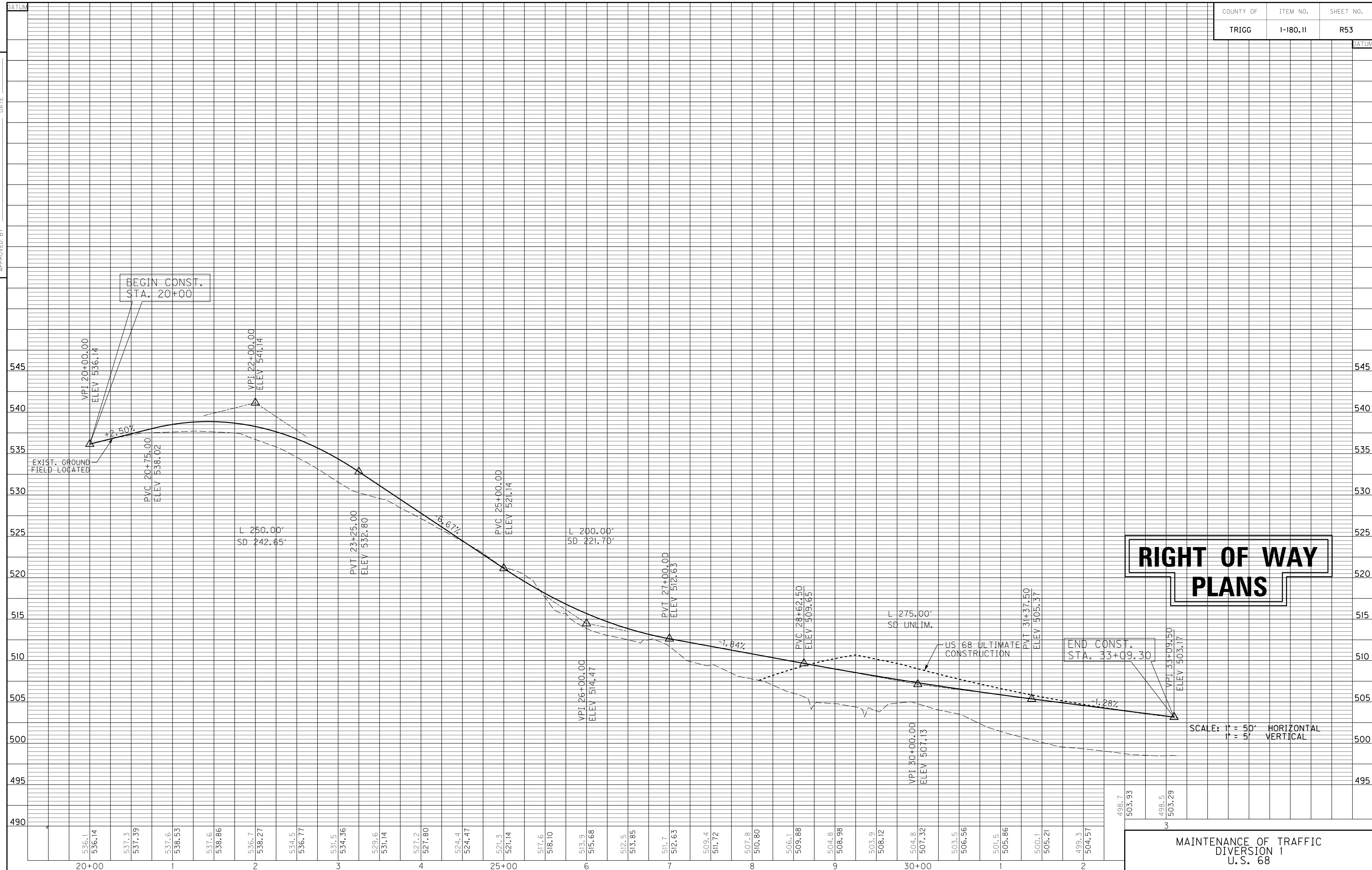

USER: \$\$\$USER\$\$\$
 DATE: \$\$\$DATE\$\$\$
 FILE NAME: \$\$\$designsfiles\$\$\$specifications\$\$\$
 E-SHEET NAME:

RIGHT OF WAY PLANS

END CONST.
STA. 33+09.30

SCALE: 1" = 50' HORIZONTAL
1" = 5' VERTICAL

498.7
503.93

498.5
503.29

MAINTENANCE OF TRAFFIC
 DIVERSION 1
 U.S. 68

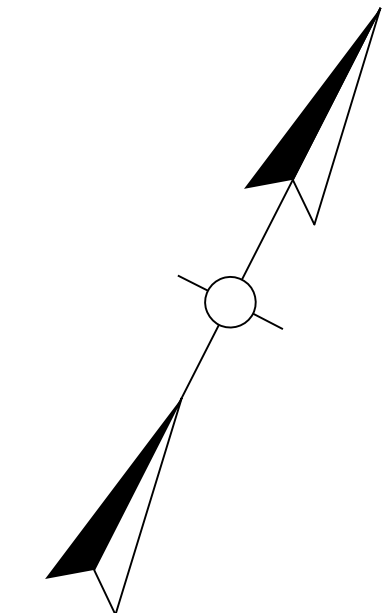

CENTERLINE OR SURVEY BASELINE DATA

DESCRIPTION	X	Y
STA 5155+00.00	1012855.10	1822340.83
TS 5158+94.85	1013246.08	1822285.70
STA 5160+00.00	1013350.25	1822271.34
SC 5160+78.85	1013428.51	1822261.72
STA 5165+00.00	1013848.88	1822241.53
STA 5170+00.00	1014346.28	1822287.50
STA 5175+00.00	1014830.96	1822408.34
PI 5176+30.68	1014964.91	1822043.36
STA 5180+00.00	1015291.73	1822601.25

CENTERLINE OR SURVEY BASELINE DATA

DESCRIPTION	X	Y
STA 5185+00.00	1015717.93	1822861.77
CS 5189+42.93	1016058.67	1823144.22
ST 4118+92.88	1016189.71	1823273.38
STA 4120+00.00	1016265.30	1823349.29
TS 4122+48.38	1016440.55	1823525.29
STA 4125+00.00	1016619.46	1823702.22
SC 4125+23.38	1016636.36	1823718.37
PI 4128+78.75	1016893.94	1823963.20
STA 4130+00.00	1016996.95	1824029.78

CENTERLINE OR SURVEY BASELINE DATA

DESCRIPTION	X	Y
CS 4132+32.92	1017183.56	1824169.13
STA 4135+00.00	1017403.97	1824319.94
ST 4135+07.92	1017410.55	1824324.36
STA 4140+00.00	1017819.27	1824598.38
STA 4145+00.00	1018234.57	1824876.82
TS 4146+34.06	1018345.92	1824951.47
SC 4149+09.06	1018572.17	1825107.75
STA 4150+00.00	1018644.78	1825162.50
PI 4154+80.38	1019048.87	1825422.76
STA 4155+00.00	1019015.14	1825497.70

KY 272 CENTERLINE OR SURVEY BASELINE DATA

DESCRIPTION	X	Y
STA 50+00.00	1018193.06	1824848.99
PC 51+06.82	1018252.55	1824760.26
PI 54+70.45	1018455.04	1824458.23
STA 55+00.00	1018545.27	1824504.53
PT 57+83.98	1018817.58	1824430.16
STA 59+14.00	1018947.21	1824420.12

AVERITT LUMBER RD.
CENTERLINE OR SURVEY BASELINE DATA

DESCRIPTION	X	Y
STA 50+00.00	1015064.17	1822495.67
STA 55+00.00	1015257.48	1822034.55
STA 57+84.88	1015367.62	1821771.83

US 68 AT KY 272
CENTERLINE OR SURVEY BASELINE DATA

DESCRIPTION	X	Y
STA 47+37.00	1018726.95	1824713.85
PC 48+54.40	1018692.95	1824601.49
STA 50+00.00	1018642.11	1824465.15
PI 51+91.61	1018595.26	1824278.73
STA 55+00.00	1018347.27	1824066.17
PT 55+10.59	1018339.26	1824059.24
STA 55+50.00	1018309.34	1824033.58

KY 1062
CENTERLINE OR SURVEY BASELINE DATA

DESCRIPTION	X	Y
STA 50+00.00	1018808.01	1824430.96
PC 50+63.46	1018802.30	1824367.75
PI 51+54.07	1018794.15	1824277.52
PT 52+44.65	1018782.74	1824187.64
STA 53+94.00	1018763.92	1824039.48

WARRENTON SCHOOL ROAD
CENTERLINE OR SURVEY BASELINE DATA

DESCRIPTION	X	Y
STA 45+00.00	1824553.83	1017071.46
PC 45+31.79	1824523.88	1017060.81
PI 45+94.16	1824465.11	1017039.91
PRC 46+55.18	1824417.50	1016999.61
PI 47+34.10	1824357.27	1016948.62
PT 47+88.80	1824293.68	1016995.35
STA 50+00.00	1824123.48	1017120.41

PI STA 4154+80.38
 $\Delta = 24^{\circ}14'19''$ LT
 $T_s = 846.32'$
 $L_s = 275.00'$
 $L_c = 1121.04'$
 $\theta_s = 2^{\circ}23'00''$ LT
 $LT = 183.35'$
 $ST = 91.68'$
 $R = 3300.00'$
 $E = 76.20'$
 $e = 4.64\%$
 $Runoff = 275'$
 $Runout = 118.53'$

FRONTAGE ROAD NO. 1

PI STA 8+07.56
 $\Delta = 67^{\circ}15'08''$ RT
 $T = 33.25'$
 $L = 58.69'$
 $R = 50.00'$
 $E = 10.05'$
 $e = NC$

PI STA 5176+30.68
 $\Delta = 53^{\circ}08'50''$ LT
 $T_s = 1742.83'$
 $L_s = 184.00'$
 $L_c = 2877.06'$
 $\theta_s = 1^{\circ}35'00''$ LT
 $LT = 122.67'$
 $ST = 61.34'$
 $R = 3300.00'$
 $E = 390.27'$
 $e = 4.6\%$
 $Runoff = 184'$
 $Runout = 80'$

HERITAGE RD.

PI STA 44+49.66
 $\Delta = 30^{\circ}27'21''$ LT
 $T = 81.66'$
 $L = 159.47'$
 $R = 300.00'$
 $E = 10.92'$
 $e = \text{SEE CROSS SECTIONS}$

HERITAGE RD.

PI STA 47+61.94
 $\Delta = 15^{\circ}22'17''$ RT
 $T = 60.73'$
 $L = 120.73'$
 $R = 450.00'$
 $E = 4.08'$
 $e = 7.4\%$
 $Runoff = 150'$
 $Runout = 40.54'$

WARRENTON SCL. RD.

PI STA 45+94.16
 $\Delta = 20^{\circ}40'20''$ RT
 $T = 62.37'$
 $L = 123.39'$
 $R = 342.00'$
 $E = 5.64'$
 $e = 4.84\%$
 $Runoff = 80'$
 $Runout = 33'$

WARRENTON SCHOOL RD.

PI STA 47+34.10
 $\Delta = 76^{\circ}33'23''$ LT
 $T = 78.91'$
 $L = 133.62'$
 $R = 100'$
 $E = 27.37'$
 $e = 7.69\%$
 $Runoff = 130'$
 $Runout = 33'$

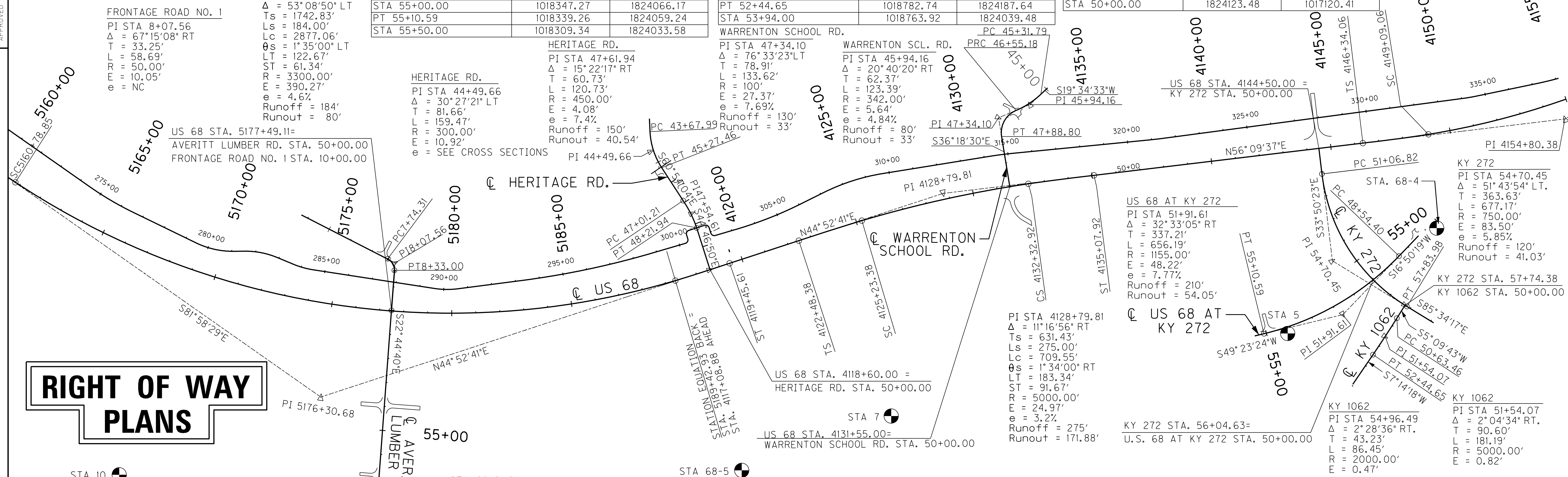

**RIGHT OF WAY
PLANS**

FRONTAGE RD. NO. 1
CENTERLINE OR SURVEY BASELINE DATA

DESCRIPTION	X	Y
STA 4+25.00	1014604.38	1822680.83
STA 5+00.00	1014679.38	1822680.80
PC 7+74.31	1014953.69	1822680.48
PI 8+07.56	1014986.95	1822680.44
PT 8+33.00	1014999.77	1822649.76
STA 10+00.00	1015064.16	1822495.67

COORDINATE CONTROL POINTS

POINT	DESCRIPTION	Project Coordinates			STATION and OFFSET	State Plane Coordinates	
		NORTH (Y)	EAST (X)	ELEV. (Z)		NORTH (Y)	EAST (X)
STA. 10	I.P. / CAP			627.34	5168 + 94.59, 904.80' RT.	1821375.0969	1014364.9210
STA. 9	I.P. / CAP			619.30	5173 + 93.63, 906.29' RT.	1821507.5212	1014986.9538
STA. 68-6	ALUMINUM DISK			582.16	5182 + 02.57, 718.91' RT.	1822080.2179	1015835.1910
STA. 68-5	ALUMINUM DISK			563.27	4117 + 41.84, 834.48' RT.	1822567.1631	1016662.5899
STA. 7	I.P. / CAP			581.61	4123 + 93.26, 811.72' RT.	1823050.5842	1017133.8630
STA. 5	I.P. / CAP			538.44	4142 + 29.72, 748.04' RT.	1824104.9841	1018426.6691
STA. 68-4	ALUMINUM DISK			536.73	4148 + 83.68, 390.12' RT.	1824776.4739	1018779.8921

HERITAGE RD.
CENTERLINE OR SURVEY BASELINE DATA

DESCRIPTION	X	Y
PC 43+67.99	1015683.65	1823647.90
PI 44+49.66	1015724.11	1823576.96
STA. 45+00.00	1015771.78	1823551.05
PT 45+27.46	1015794.94	1823536.31
PC 47+01.21	1015945.65	1823449.83
PI 47+61.94	1015998.32	1823419.61
PT 48+21.94	1016041.09	1823376.50
STA 50+00.00	1016166.52	1823250.11

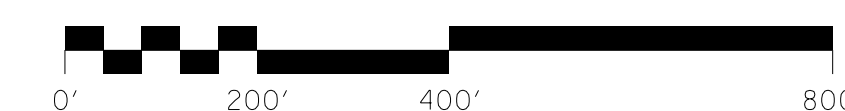

CONTROL DATA SHEET
STA. 5160+43.45 TO STA. 4155+00

SCALE: 1"=200'

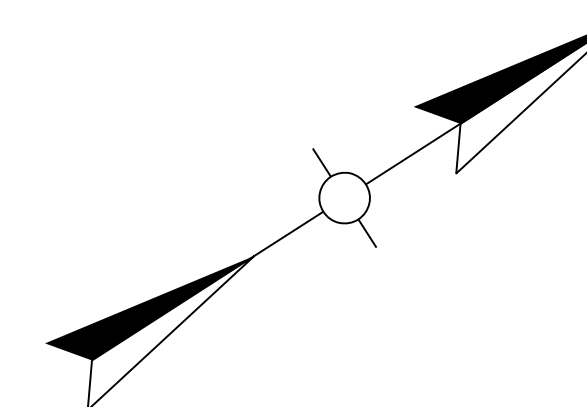

PREPARED BY _____ DATE _____
 CHECKED BY _____ DATE _____
 APPROVED BY _____ DATE _____

CENTERLINE OR SURVEY BASELINE DATA

DESCRIPTION	X	Y
STA 4155+00.00	1019015.14	1825497.70
STA 4160+00.00	1019330.66	1825884.95
CS 4160+30.10	1019347.74	1825909.74
ST 4163+05.10	1019496.37	1826141.09
STA 4165+00.00	1019599.42	1826306.52
STA 4170+00.00	1019863.80	1826730.90
STA 4175+00.00	1020128.18	1827155.29

CENTERLINE OR SURVEY BASELINE DATA

DESCRIPTION	X	Y
STA 4180+00.00	1020392.56	1827579.67
STA 4185+00.00	1020656.94	1828004.06
STA 4190+00.00	1020921.32	1828428.45
STA 4195+00.00	1021185.70	1828852.83
PC 4195+08.52	1021190.20	1828860.07
PI 4199+65.44	1021431.80	1829247.88
STA 4200+00.00	1021434.31	1829286.51

CENTERLINE OR SURVEY BASELINE DATA

DESCRIPTION	X	Y
PT 4204+20.90	1021617.65	1829665.29
STA 4205+00.00	1021649.83	1829737.56
STA 4210+00.00	1021853.21	1830194.33
TS 4210+74.18	1021883.39	1830262.12
SC 4213+74.21	1022012.51	1830532.82
STA 4215+00.00	1022076.13	1830641.31

CENTERLINE OR SURVEY BASELINE DATA
MACK CUNNINGHAM RD.

DESCRIPTION	X	Y
STA 50+00.00	1020857.88	1828326.62
PC 51+14.34	1020954.93	1828266.16
PI 51+82.20	1021012.52	1828230.28
PT 52+49.23	1021077.60	1828211.05

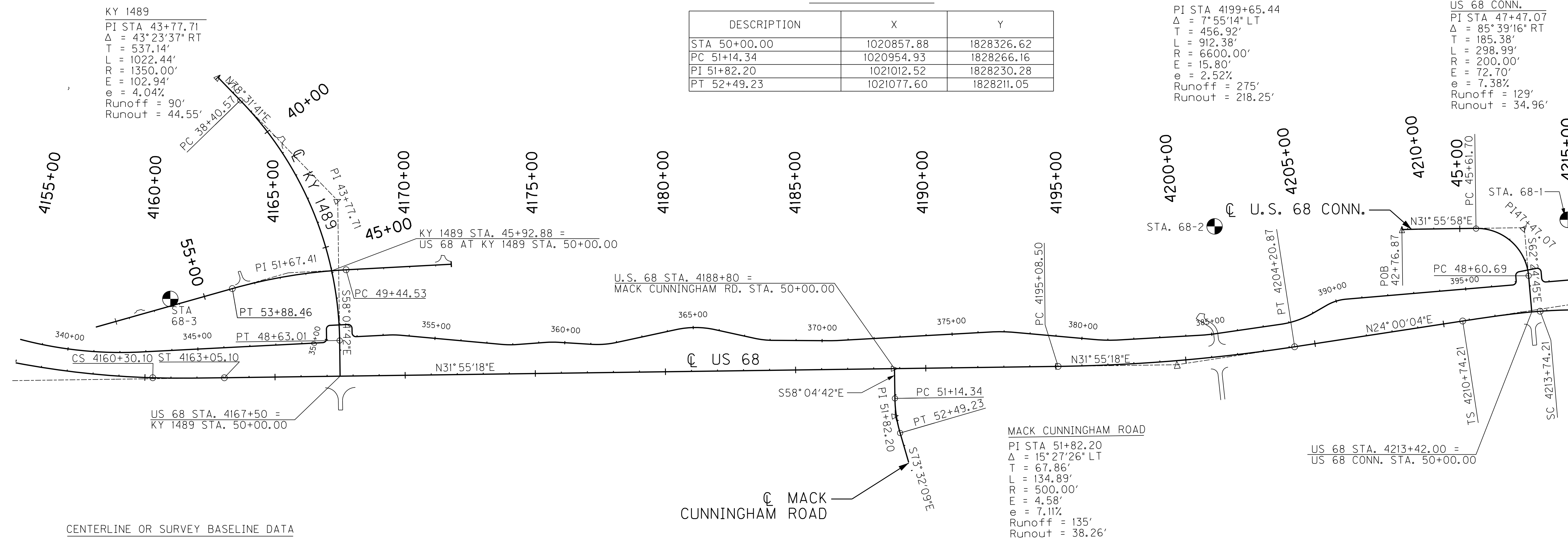

CENTERLINE OR SURVEY BASELINE DATA
KY 1489

DESCRIPTION	X	Y
STA 37+53.00	1018547.21	1826750.94
PC 38+40.57	1018633.03	1826768.35
STA 40+00.00	1018790.78	1826790.77
PI 43+77.71	1019159.44	1826875.18
STA 45+00.00	1019285.29	1826739.63
STA 45+92.88	1019373.36	1826710.18
PT 48+63.01	1019615.35	1826591.17
STA 50+00.00	1019731.63	1826518.73

CENTERLINE OR SURVEY BASELINE DATA
US 68 AT KY 1489

DESCRIPTION	X	Y
STA 45+40.00	1019600.37	1827110.26
PC 49+44.53	1019400.14	1826758.75
STA 50+00.00	1019373.36	1826710.18
PI 51+67.41	1019289.82	1826565.09
PT 53+88.46	1019224.85	1826351.89
STA. 54+60.00	1019203.99	1826283.46

COORDINATE CONTROL POINTS

POINT	DESCRIPTION	Project Coordinates			STATION and OFFSET	State Plane Coordinates	
		NORTH (Y)	EAST (X)	ELEV. (Z)		NORTH (Y)	EAST (X)
STA. 68-3	ALUMINUM DISK			516.16	4160 + 94.29, 304.01' LT.	1826130.1241	1019129.4234
STA. 68-2	ALUMINUM DISK			502.07	4201 + 67.76, 498.98' LT.	1829656.3854	1021062.5605
STA. 68-1	ALUMINUM DISK			517.37	4214 + 85.41, 346.55' LT.	1830532.7648	1021773.9846

CENTERLINE OR SURVEY BASELINE DATA
US 68 CONN.

DESCRIPTION	X	Y
STA 42+76.87	1021460.91	1830255.72
STA 45+00.00	1021578.93	1830445.09
PC 45+61.70	1021611.57	1830497.45
PI 47+47.07	1021709.62	1830654.77
PT 48+60.69	1021873.92	1830568.92
STA 50+00.00	1021997.40	1830504.41

**RIGHT OF WAY
PLANS**

CONTROL DATA SHEET
STA. 4155+00 TO STA. 4215+00



USER: \$\$\$USER\$\$\$
 DATE: \$\$\$DATE\$\$\$
 FILE NAME: \$\$\$designsfiles\$specifications\$\$\$
 E-SHEET NAME:

CENTERLINE OR SURVEY BASELINE DATA
BRAYBOY-HANDLEY LN.

DESCRIPTION	X	Y
STA 50+00.00	1022820.08	1831863.23
STA 51+30	1022690.89	1831877.76

CENTERLINE OR SURVEY BASELINE DATA

DESCRIPTION	X	Y
STA 4215+00.00	1022076.13	1830641.31
STA 4220+00.00	1022395.11	1831024.49
STA 4225+00.00	1022802.39	1831312.07
PI 4227+06.42	1022583.21	1831703.58
STA 4230+00.00	1023270.22	1831484.43
STA 4235+00.00	1023766.72	1831529.84
CS 4237+00.71	1023966.49	1831511.36
STA 4240+00.00	1024259.90	1831452.77

CENTERLINE OR SURVEY BASELINE DATA

DESCRIPTION	X	Y
ST 4240+00.71	1024260.60	1831452.61
STA 4245+00.00	1024747.48	1831342.03
PC 4246+13.81	1024858.47	1831316.82
PI 4248+36.22	1025075.35	1831267.56
STA 4250+00.00	1025237.66	1831244.04
PT 4250+58.40	1025295.40	1831235.27
STA 4255+00.00	1025732.32	1831171.14
TS 4258+59.30	1026087.81	1831118.96

CENTERLINE OR SURVEY BASELINE DATA

DESCRIPTION	X	Y
STA 4260+00.00	1026227.11	1831099.16
SC 4261+09.30	1026335.63	1831086.23
PI 4264+91.75	1026716.08	1831047.12
STA 4265+00.00	1026725.80	1831072.66
CS 4268+69.78	1027093.59	1831108.42
STA 4270+00.00	1027221.71	1831131.68
ST 4271+19.78	1027339.08	1831155.58
STA 4275+00.00	1027711.42	1831232.71
POE 4277+93.91	1027999.19	1831292.32

PREPARED BY _____ DATE _____
 CHECKED BY _____ DATE _____
 APPROVED BY _____ DATE _____

BRAYBOY-HANDLEY LANE

PI STA 52+29.32
 $\Delta = 47^\circ 21' 54''$ LT
 T = 76.76'
 L = 144.67'
 R = 175.00'
 e = 16.09'

PI 44+50.79

N83°34'55"W

BRAYBOY HANDLEY LANE

U.S. 68 STA. 4226+50.00 =
 U.S. 68 X (CANTON ROAD) STA. 50+00.00
 CLARKSDALE ROAD STA. 50+00.00

CANTON RD.
 PI STA 44+50.79
 $\Delta = 68^\circ 55' 32''$ LT
 T = 413.93'
 L = 725.53'
 R = 603.11'
 E = 128.38'
 e = 6.53%
 Runoff = 129'
 Runout = 39.51'

U.S. 68X (CANTON RD.) STA. 44+94.00 =
 BRAYBOY HANDLEY LANE STA. 50+00.00

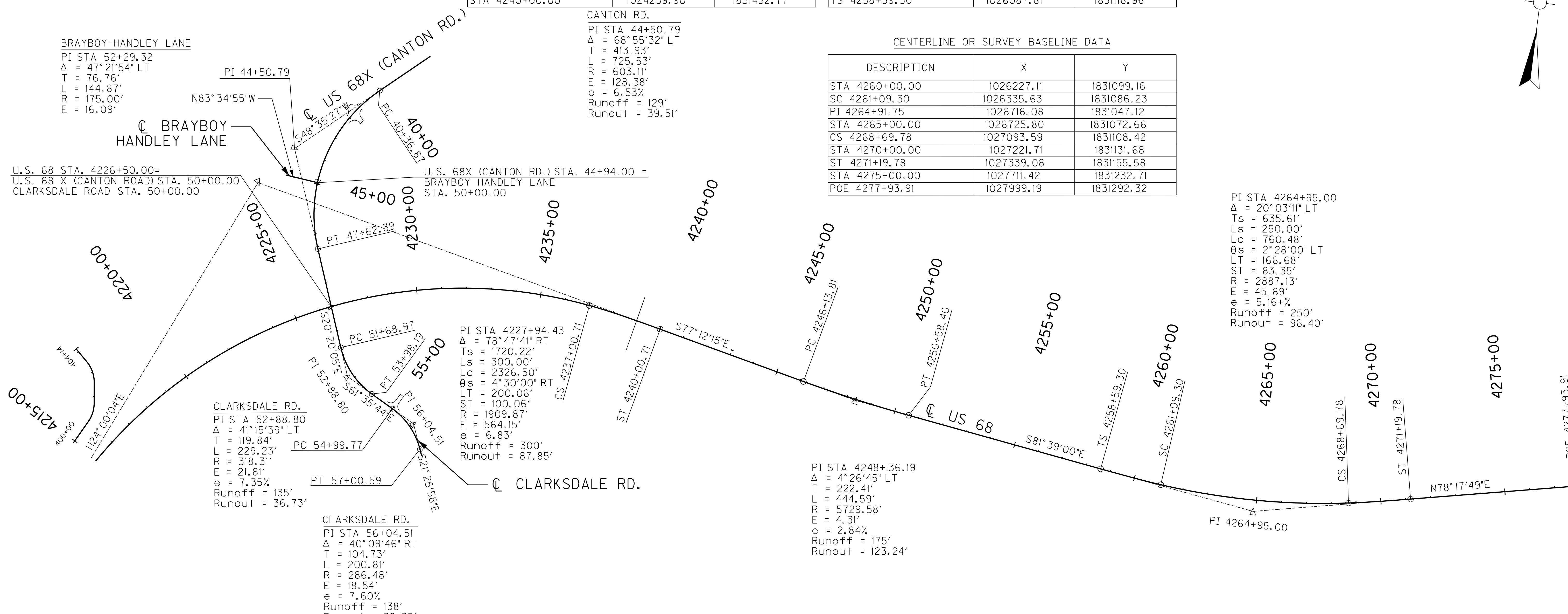

CLARKSDALE RD.

PI STA 52+88.80
 $\Delta = 41^\circ 15' 39''$ LT
 T = 119.84'
 L = 229.23'
 R = 318.31'
 E = 21.81'
 e = 7.35%
 Runoff = 135'
 Runout = 36.73'

PI STA 4227+94.43
 $\Delta = 78^\circ 47' 41''$ RT
 Ts = 1720.22'
 Ls = 300.00'
 Lc = 2326.50'
 $\theta_s = 4^\circ 30' 00''$ RT
 LT = 200.06'
 ST = 100.06'
 R = 1909.87'
 E = 564.15'
 e = 6.83%
 Runoff = 300'
 Runout = 87.85'

CLARKSDALE RD.

PI STA 56+04.51
 $\Delta = 40^\circ 09' 46''$ RT
 T = 104.73'
 L = 200.81'
 R = 286.48'
 E = 18.54'
 e = 7.60%
 Runoff = 138'
 Runout = 36.32'

CENTERLINE OR SURVEY BASELINE DATA
U.S. 68X (CANTON / CLARKSDALE RD.)

DESCRIPTION	X	Y
PC 40+36.87	1023021.83	1832261.30
STA 41+47.00	1022946.32	1832181.33
PI 44+50.79	1022711.38	1831987.51
STA 45+00.00	1022819.57	1831857.25
PT 47+62.39	1022855.22	1831599.38
STA 50+00.00	1022937.79	1831376.58
PC 51+68.97	1022996.51	1831218.14
PI 52+88.80	1023038.15	1831105.77
PT 53+98.19	1023143.56	1831048.77
PC 54+99.77	1023232.91	1831000.45
STA 55+00.00	1023233.11	1831000.34
PI 56+04.51	1023325.04	1830950.63
PT 57+00.59	1023363.31	1830853.14

PI STA 4264+95.00
 $\Delta = 20^\circ 03' 11''$ LT
 Ts = 635.61'
 Ls = 250.00'
 Lc = 760.48'
 $\theta_s = 2^\circ 28' 00''$ LT
 LT = 166.68'
 ST = 83.35'
 R = 2887.13'
 E = 45.69'
 e = 5.16%
 Runoff = 250'
 Runout = 96.40'

PI STA 4248+36.19
 $\Delta = 4^\circ 26' 45''$ LT
 T = 222.41'
 L = 444.59'
 R = 5729.58'
 E = 4.31'
 e = 2.84%
 Runoff = 175'
 Runout = 123.24'

USER: \$\$\$USER\$\$\$
 DATE: \$\$\$DATE\$\$\$
 FILE NAME: \$\$\$designsfiles\$specifications\$\$\$
 E-SHEET NAME:

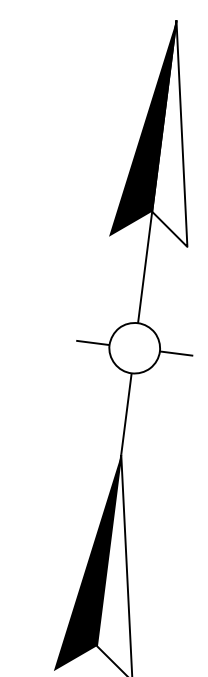

**RIGHT OF WAY
PLANS**

CONTROL DATA SHEET
 STA. 4215+00 TO STA. 4277+94

COORDINATE CONTROL

PREPARED BY _____ DATE _____
 CHECKED BY _____ DATE _____
 APPROVED BY _____ DATE _____

U. S. 68 MAINLINE			
STATION	OFFSET	NORTHING	EASTING
5160+43.45	LT. 200	1,822,464.37	1,013,417.65
5160+43.45	RT. 115	1,822,151.70	1,013,379.37
5162+75	LT. 290	1,822,535.21	1,013,639.15
5164+50	RT. 225	1,822,016.10	1,013,799.08
5167+50	RT. 130	1,822,125.60	1,014,110.42
5169+00	LT. 135	1,822,405.98	1,014,228.91
5171+50	LT. 230	1,822,540.75	1,014,444.71
5172+96.15	LT. 191.13	1,822,534.97	1,014,586.78
5174+00	LT. 160	1,822,531.61	1,014,689.84
5174+25	RT. 135	1,822,256.47	1,014,799.10
5175+15	LT. 210	1,822,612.11	1,014,778.14
5176+75	RT. 110	1,822,365.45	1,015,035.66
5177+00	LT. 160	1,822,625.58	1,014,959.21
5178+00	LT. 170	1,822,671.48	1,015,042.96
5178+50	RT. 110	1,822,435.92	1,015,202.20
5179+50	LT. 135	1,822,699.96	1,015,187.42
5182+00	RT. 135	1,822,581.40	1,015,535.57
5185+00	LT. 175	1,823,003.71	1,015,615.57
5187+75	RT. 155	1,822,914.05	1,016,034.85
5188+50	LT. 250	1,823,267.28	1,015,823.44
4117+50	LT. 215	1,823,326.96	1,015,938.56
4117+50	RT. 85	1,823,111.73	1,016,147.54
4119+50	LT. 200	1,823,454.98	1,016,088.30
4124+25	RT. 210	1,823,500.12	1,016,712.77
4125+00	LT. 230	1,823,868.22	1,016,460.26
4131+00	LT. 215	1,824,262.52	1,016,947.06
4131+25	RT. 245	1,823,909.09	1,017,242.54
4132+00	LT. 249.53	1,824,352.37	1,017,010.85
4132+20	LT. 190	1,824,316.19	1,017,062.53
4132+25	RT. 120	1,824,066.85	1,017,246.80
4133+00	LT. 200	1,824,372.02	1,017,124.49
4133+50	RT. 145	1,824,116.32	1,017,361.49
4139+50	RT. 135	1,824,458.41	1,017,852.92
4143+50	RT. 120	1,824,693.61	1,018,176.81
4145+50	RT. 115	1,824,809.14	1,018,340.14
4147+75	RT. 125	1,824,927.32	1,018,533.44
4151+45	RT. 116.29	1,825,165.22	1,018,832.60
4152+00	LT. 175	1,825,421.33	1,018,683.54
4152+56.48	RT. 114.84	1,825,242.44	1,018,918.34
4153+50	LT. 190	1,825,528.24	1,018,777.72
4155+50	LT. 110.17	1,825,608.85	1,018,968.25
4156+00	RT. 135	1,825,481.31	1,019,183.56
4159+00	RT. 125	1,825,729.28	1,019,372.71
4159+75	LT. 209.92	1,825,985.69	1,019,144.91
4160+00	LT. 190	1,825,993.47	1,019,174.71
4164+25	RT. 130	1,826,174.12	1,019,670.11
4166+35	LT. 200	1,826,526.85	1,019,501.05
4168+00	RT. 130	1,826,492.41	1,019,868.39
4168+50	LT. 215	1,826,717.27	1,019,602.00

U. S. 68 MAINLINE			
STATION	OFFSET	NORTHING	EASTING
4169+10	RT. 145	1,826,577.84	1,019,939.29
4171+00	LT. 205	1,826,924.18	1,019,742.68
4171+50	RT. 115	1,826,797.41	1,020,040.72
4173+50	RT. 125	1,826,961.88	1,020,154.96
4178+00	LT. 145	1,827,486.59	1,020,163.74
4178+00	RT. 125	1,827,343.83	1,020,392.90
4179+50	LT. 220	1,827,653.56	1,020,179.39
4181+70	RT. 165	1,827,636.72	1,020,622.50
4182+00	LT. 230	1,827,871.04	1,020,303.09
4184+00	LT. 155	1,828,001.14	1,020,472.50
4186+00	RT. 120	1,828,025.49	1,020,811.67
4186+50	LT. 155	1,828,213.33	1,020,604.69
4186+98.21	RT. 131.05	1,828,103.01	1,020,872.97
4187+15	LT. 142	1,828,261.63	1,020,650.10
4188+25	RT. 125.50	1,828,213.55	1,020,935.31
4189+75	RT. 130	1,828,338.49	1,021,018.44
4190+00	LT. 175	1,828,520.98	1,020,772.78
4192+00	RT. 103	1,828,543.74	1,021,114.49
4193+00	LT. 175	1,828,775.61	1,020,931.41
4194+00	RT. 125	1,828,701.86	1,021,238.92
4196+00	LT. 150	1,829,015.59	1,021,109.63
4199+50	RT. 100	1,829,195.22	1,021,499.16
4200+45	LT. 145	1,829,392.86	1,021,326.17
4202+00	RT. 150	1,829,399.47	1,021,659.35
4203+00	LT. 160	1,829,623.05	1,021,422.52
4204+50	LT. 140	1,829,748.83	1,021,501.60
4204+50	RT. 125	1,829,641.04	1,021,743.68
4206+25	RT. 150	1,829,790.74	1,021,837.70
4206+50	LT. 215	1,829,962.04	1,021,514.43
4212+00	RT. 115	1,830,328.57	1,022,039.49
4212+50	LT. 175	1,830,497.52	1,021,798.44
4212+65	LT. 193.23	1,830,519.74	1,021,788.90
4214+25	LT. 180	1,830,667.19	1,021,881.49
4215+90	LT. 195	1,830,828.02	1,021,966.18
4216+75	RT. 105	1,830,720.83	1,022,259.50
4218+25	RT. 185	1,830,776.19	1,022,409.59
4219+35	LT. 180	1,831,107.59	1,022,221.56
4220+50	RT. 100	1,830,982.72	1,022,498.18
4223+65.23	LT. 159.86	1,831,381.12	1,022,601.23
4225+38.33	RT. 139.36	1,831,204.92	1,022,898.84

AVERITT LUMBER ROAD			
STATION	OFFSET	NORTHING	EASTING
53+50	LT. 105	1,822,213.48	1,015,296.32
53+50	RT. 100	1,822,134.23	1,015,107.26
55+25	LT. 90	1,822,046.29	1,015,350.14
57+52.12	LT. 90	1,821,836.83	1,015,437.95
57+77.39	RT. 75	1,821,749.74	1,015,295.55

HERITAGE ROAD			
STATION	OFFSET	NORTHING	EASTING
45+15	RT. 24.79	1,823,521.76	1,015,771.05
45+15	RT. 40.28	1,823,508.90	1,015,762.94
45+40	LT. 26.27	1,823,552.85	1,015,818.89
45+45	RT. 40	1,823,492.89	1,015,790.25
45+58.78	RT. 33.86	1,823,491.36	1,015,805.26
45+59.92	RT. 23.12	1,823,500.10	1,015,811.59
46+00	LT. 36.72	1,823,532.06	1,015,876.14
46+15	LT. 55	1,823,540.45	1,015,898.25
46+35	LT. 55	1,823,530.49	1,015,915.59
46+50	LT. 45.43	1,823,514.73	1,015,923.84
47+00	LT. 54.14	1,823,497.40	1,015,971.54
47+00	RT. 88.39	1,823,373.77	1,015,900.61

WARRENTON SCHOOL ROAD			
STATION	OFFSET	NORTHING	EASTING
45+00	RT. 7.21	1,824,556.25	1,017,064.67
46+25	LT. 22.57	1,824,428.36	1,017,036.52
47+25	RT. 45	1,824,353.51	1,016,930.94

KY 272			
STATION	OFFSET	NORTHING	EASTING
52+50	LT. 70	1,824,698.95	1,018,392.80
53+50	RT. 80	1,824,520.16	1,018,369.28
55+40	RT. 60	1,824,432.68	1,018,558.12
56+50	RT. 80	1,824,374.95	1,018,665.38
57+15	RT. 80	1,824,359.78	1,018,735.67
58+50	RT. 50	1,824,375.21	1,018,879.54
59+25	LT. 29.26	1,824,448.44	1,018,960.44
59+25	LT. 50	1,824,469.12	1,018,962.04
59+25	RT. 30.72	1,824,388.64	1,018,955.81

U. S. 68 @ KY 272			
STATION	OFFSET	NORTHING	EASTING
47+20	LT. 28.98	1,824,721.73	1,018,759.61
47+20	LT. 45	1,824,717.09	1,018,774.95
47+50.74	RT. 55	1,824,716.63	1,018,670.33
47+51.05	RT. 30.99	1,824,709.38	1,018,693.23
49+45	LT. 75	1,824,488.61	1,018,733.19
49+45	RT. 60	1,824,537.72	1,018,607.44
51+75	LT. 100	1,824,257.28	1,018,643.06
53+00	LT. 110	1,824,140.95	1,018,571.34
54+50	LT. 65	1,824,052.80	1,018,429.04
55+25	LT. 29.84	1,824,027.20	1,018,347.75
55+25	RT. 30.16	1,824,072.75	1,018,308.69
55+25	RT. 65	1,824,099.20	1,018,286.01

KY 1062			
STATION	OFFSET	NORTHING	EASTING
52+50	RT. 65	1,824,190.52	1,018,717.58
54+00	LT. 32.59	1,824,029.42	1,018,795.50
54+00	RT. 23.45	1,824,036.48	1,018,739.90
54+00	RT. 45	1,824,039.19	1,018,718.52

KY 1489			
STATION	OFFSET	NORTHING	EASTING
37+55	LT. 22.18	1,826,773.07	1,018,544.75
37+55	RT. 29.11	1,826,722.81	1,018,554.96
39+35	LT. 75	1,826,858.25	1,018,716.41
40+00	RT. 55	1,826,735.96	1,018,795.29
40+30	LT. 34.78	1,826,827.62	1,018,818.62
45+25	RT. 55	1,826,679.87	1,019,292.58
46+50	RT. 60	1,826,633.82	1,019,403.11
46+85	LT. 60	1,826,729.73	1,019,483.26

U. S. 68 @ KY 1489			
STATION	OFFSET	NORTHING	EASTING
45+40	LT. 30.49	1,827,095.17	1,019,626.87
45+40	RT. 29.99	1,827,125.10	1,019,574.31
47+65	RT. 74.68	1,826,951.72	1,019,424.12
52+00	RT. 60	1,826,552.13	1,019,232.70
54+25	RT. 60	1,826,334.43	1,019,156.80
54+60	LT. 30.31	1,826,274.62	1,019,232.99
54+60	RT. 29.70	1,826,292.12	1,019,175.59

MACK CUNNINGHAM ROAD			
STATION	OFFSET	NORTHING	EASTING
52+50	RT. 55	1,828,158.08	1,021,062.75
53+00	LT. 65	1,828,258.99	1,021,144.71
53+25	RT. 35	1,828,156.01	1,021,140.34
53+43.16	RT. 15.32	1,828,169.73	1,021,163.34
53+60	LT. 19.09	1,828,197.96	1,021,189.24

U. S. 68 CONNECTOR			
STATION	OFFSET	NORTHING	EASTING
46+70	LT. 116.28	1,830,673.37	1,021,637.51

CLARKSDALE ROAD			
STATION	OFFSET	NORTHING	EASTING
52+99.95	RT. 40.33	1,831,080.02	1,023,036.61
53+95	RT. 55	1,831,002.19	1,023,114.11

FRONTAGE ROAD NO. 1			
STATION	OFFSET	NORTHING	EASTING
4+00	RT. 20	1,822,660.91	1,014,579.36
4+00	LT. 20	1,822,700.91	1,014,579.41
4+26.55	RT. 40	1,822,640.88	1,014,605.89
4+43.53	LT. 55	1,822,735.86	1,014,622.97
4+47.67	LT. 78.14	1,822,758.99	1,014,627.14
5+64.85	LT. 100.23	1,822,790.95	1,014,744.36
7+00	LT. 60	1,822,740.56	1,014,879.45
7+37	LT. 80	1,822,760.52	1,014,916.47
7+60	LT. 80	1,822,760.49	1,014,939.47
7+95	LT. 53.59	1,822,725.28	1,014,995.39

RIGHT OF WAY
 PLANS

USER: \$\$\$USER\$\$\$
 DATE: \$\$\$